

4. Front and Rear Drive Shafts

B: DISASSEMBLY

2. FWD MODEL

- 1) Remove both DOJ boot bands.
- 2) Loosen band by means of screwdriver or pliers taking care to not damage the boot.
- 3) Remove the larger end of DOJ boot from DOJ outer race.
- 4) Pry and remove round circlip located at the neck of DOJ outer race with a screwdriver.

- 5) Take out DOJ outer race from shaft assembly.
- 6) Wipe off grease and take out balls.

CAUTION:

The grease is a special grease (grease for constant velocity joint). Do not confuse with other greases.

NOTE:

Disassemble exercising care not to lose balls (6 pcs).

- ① Outer race
- ② Grease

NOTE:

Clean all parts as necessary.

- 7) To remove the cage from the inner race, turn the cage by a half pitch to the track groove of the inner race and shift the cage.
- 8) Remove snap ring, which holds the inner race to shaft, by using pliers.
- 9) Take out DOJ inner race.
- 10) Take off DOJ cage from shaft and remove DOJ boot.

CAUTION:

Be sure to wrap shaft splines with vinyl tape to protect the boot from scratches.

- 11) Place drive shaft in a vise between wooden blocks.

CAUTION:

Do not place drive shaft directly in the vise; use wooden block.

- 12) Raise boot band claws by means of screwdriver and hammer.

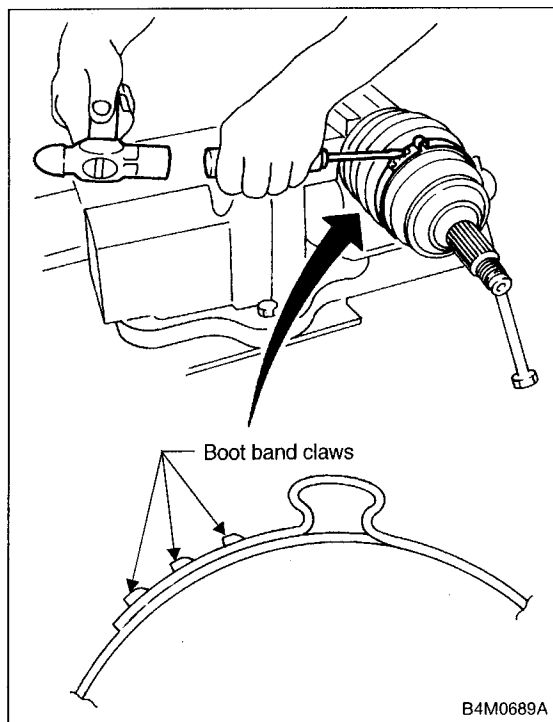

- 13) Cut and remove the boot.

CAUTION:

The boot must be replaced with a new one whenever it is removed.

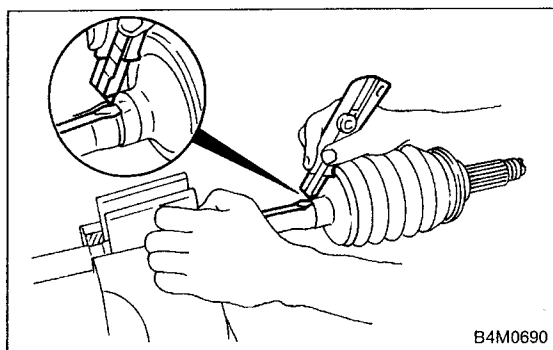

14) Thus, disassembly of axle is completed, but UFJ cannot be disassembled.

D: ASSEMBLY

2. FWD MODEL

Use specified grease.

UFJ side:

UFJ (Front) — NTG2218 (Part No. 28093AA020)

DOJ side:

AT model (Front) — VU-3A702 (Yellow) (Part No. 23223GA050)

MT model (Front) — Molylex No. 2 (Part No. 723223010) or Sunlight TB2-A

1) Place UFJ boot and small boot band on UFJ side of shaft.

CAUTION:

Be sure to wrap shaft splines with vinyl tape to prevent boot from scratches.

2) Place drive shaft in a vise.

CAUTION:

Do not place drive shaft directly in the vise; use wooden blocks.

3) Apply a coat of specified grease [60 to 70 g (2.12 to 2.47 oz)] to UFJ.

4) Apply an even coat of specified grease [20 to 30 g (0.71 to 1.06 oz)] to the entire inner surface of boot. Also apply grease to shaft.

NOTE:

The inside of the larger end of UFJ boot and the boot groove shall be cleaned so as to be free from grease and other substances.

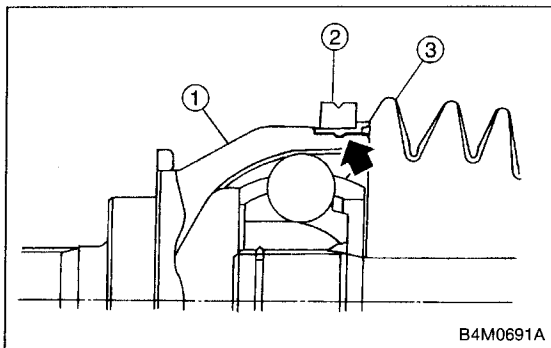

5) Install boot projecting portion to UFJ groove.

① UFJ

② Large boot band

③ Boot

6) Set large boot band in place.

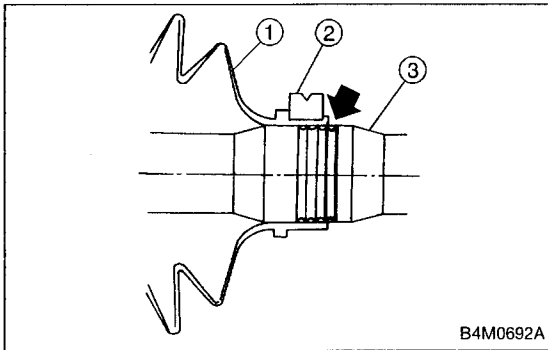

7) Align the boot end of the smaller diameter with the 3rd groove in the drive shaft as shown in the figure.

- ① Boot
- ② Small boot band
- ③ Shaft

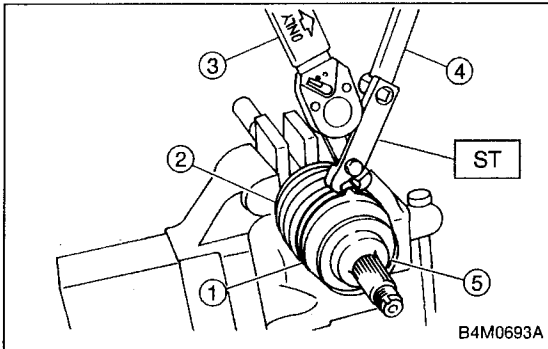

8) Tighten boot bands using ST, torque wrench and socket flex handle.

ST 28099AC000 BOOT BAND PLIER

- ① Large boot band
- ② Boot
- ③ Torque wrench
- ④ Socket flex handle
- ⑤ UFJ

Tightening torque:

Large boot band

152 N·m (16.0 kg-m, 116 ft-lb) or more

Small boot band

133 N·m (13.6 kg-m, 98 ft-lb) or more

9) Place DOJ boot at the center of shaft.

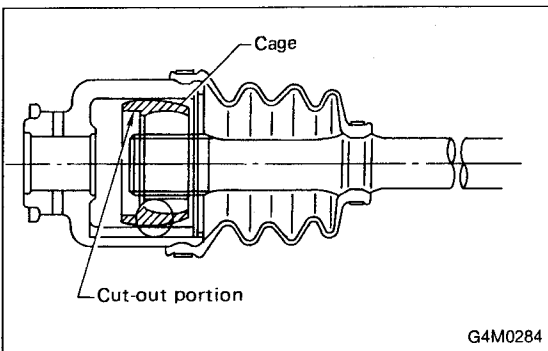

10) Insert DOJ cage onto shaft.

NOTE:

Insert the cage with the cut-out portion facing the shaft end, since the cage is directional.

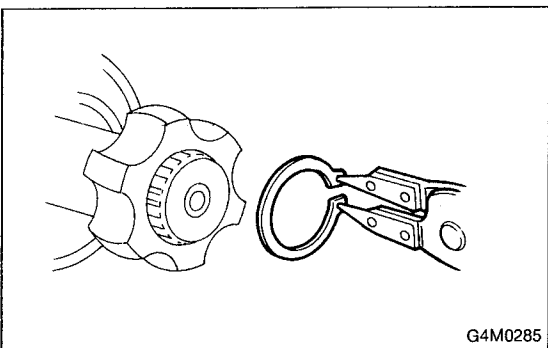

11) Install DOJ inner race on shaft and fit snap ring with pliers.

NOTE:

Confirm that the snap ring is completely fitted in the shaft groove.

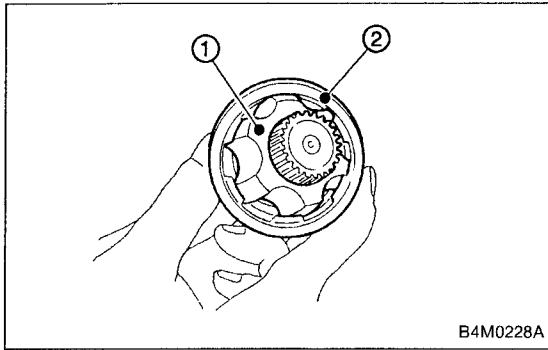

12) Install cage, which was previously fitted, to inner race fixed upon shaft.

NOTE:

Fit the cage with the protruded part aligned with the track on the inner race and then turn by a half pitch.

- ① Inner race
- ② Cage

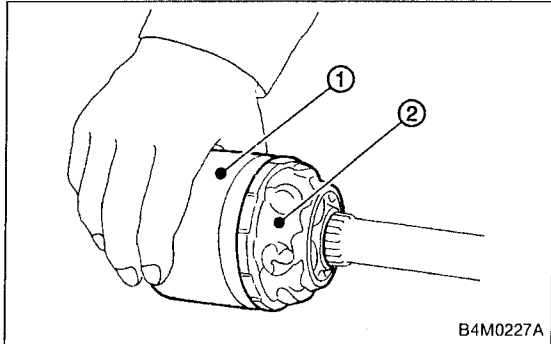

13) Put 80 to 90 g (2.82 to 3.17 oz) of specified grease into the interior of DOJ outer race.

14) Apply a coat of specified grease to the cage pocket and six balls.

15) Insert six balls into the cage pocket.

16) Align the outer race track and ball positions and place in the part where shaft, inner race, cage and balls are previously installed, and then fit outer race.

- ① Outer race
- ② Grease

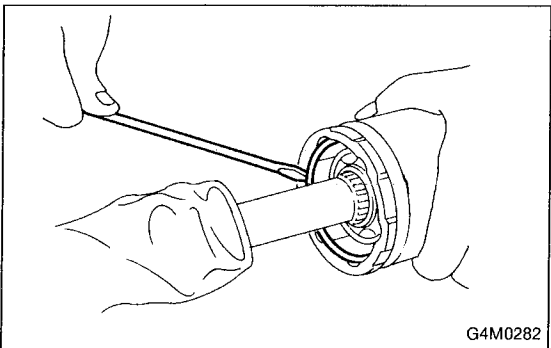

17) Install circlip in the groove on DOJ outer race.

NOTE:

- Assure that the balls, cage and inner race are completely fitted in the outer race of DOJ.
- Exercise care not to match the open end of circlip in the ball groove of outer race.
- Pull the shaft lightly and assure that the circlip is completely fitted in the groove.

18) Apply an even coat of specified grease [20 to 30 g (0.71 to 1.06 oz)] to the entire inner surface of boot. Also apply grease to shaft.

19) Install DOJ boot taking care not to twist it.

NOTE:

- The inside of the larger end of DOJ boot and the boot groove shall be cleaned so as to be free from grease and other substances.
- When installing DOJ boot, position outer race of DOJ at center of its travel.

20) Put a band through the clip and wind twice in alignment with band groove of boot.

CAUTION:

Use a new band.

21) Pinch the end of band with pliers. Hold the clip and tighten securely.

NOTE:

When tightening boot, exercise care so that the air within the boot is appropriate.

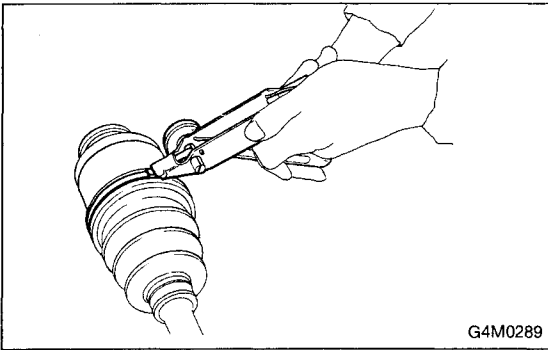

22) Tighten band by using ST.

ST 925091000 BAND TIGHTENING TOOL

NOTE:

Tighten band until it cannot be moved by hand.

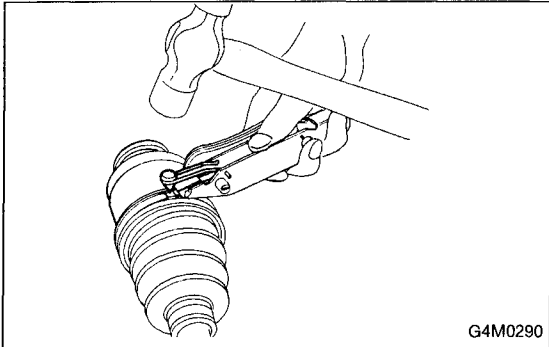

23) Tap on the clip with the punch provided at the end of ST.

ST 925091000 BAND TIGHTENING TOOL

CAUTION:

Tap only to the extent that the boot underneath is not damaged.

24) Cut off band with an allowance of about 10 mm (0.39 in) left from the clip and bend this allowance over the clip.

CAUTION:

Be careful so that the end of the band is in close contact with clip.

25) Fix up boot on UFJ in the same manner.

NOTE:

Extend and retract DOJ to provide equal grease coating.