

4. Datum Points and Dimensions Concerning On-Board Aiming Adjustment

If headlight aiming is misaligned due to damaged body panel, repair headlight mating surface using body and headlight datum points as a guide.

NOTE:

It is recommended to conduct On-Board Aiming Adjustment with headlights turned off. If turned on during the adjustment, the duration should be within two minutes.

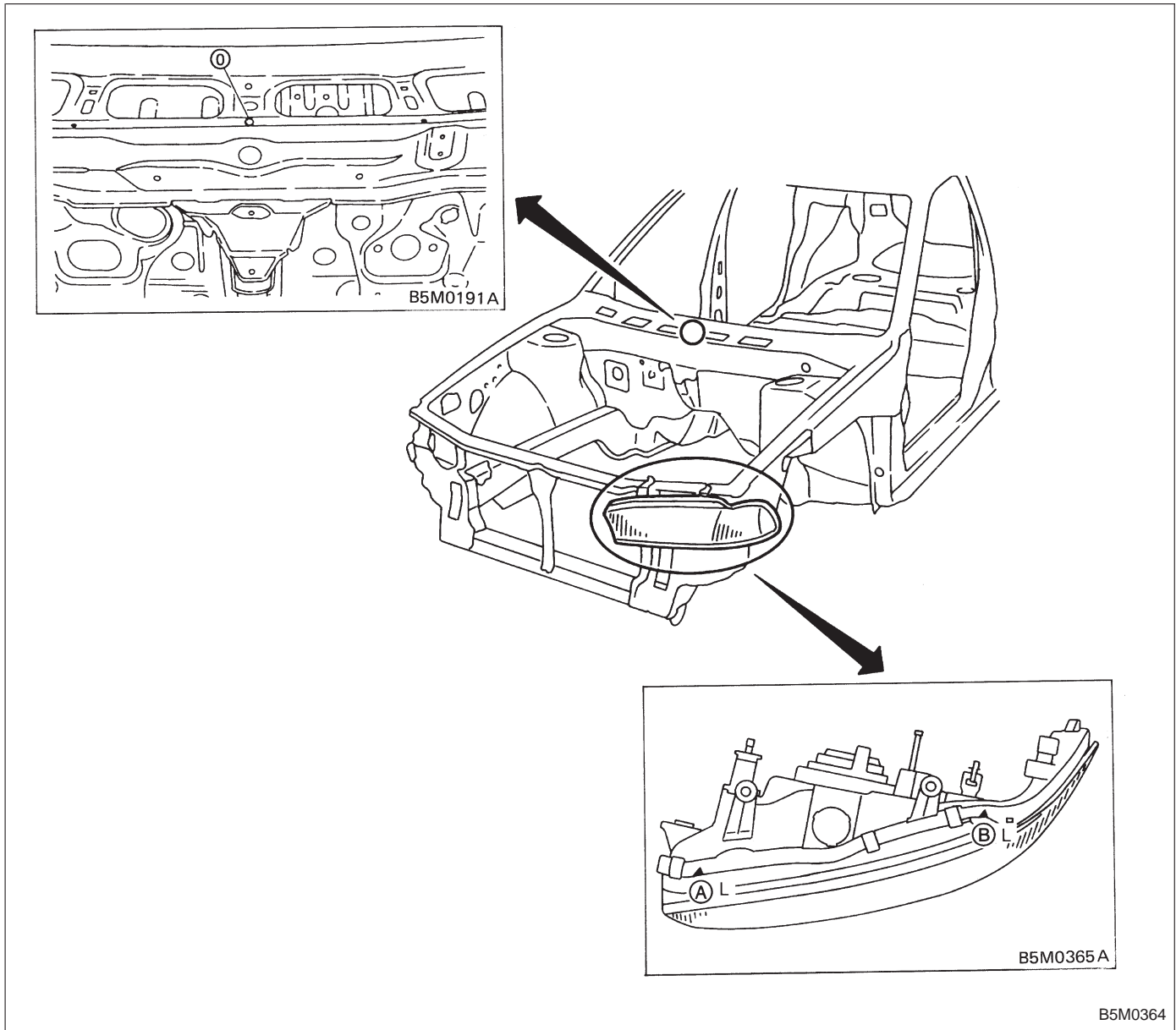

$$\left. \begin{matrix} \text{O} - \text{A}_L \\ \text{O} - \text{A}_R \end{matrix} \right\} : 1,015 (39.96)$$

$$\left. \begin{matrix} \text{O} - \text{B}_L \\ \text{O} - \text{B}_R \end{matrix} \right\} : 1,057 (41.61)$$

Unit: mm (in)