

## 15. Horn and Cigarette Lighter

### A: REMOVAL AND INSTALLATION

#### 1. HORN

- 1) Open the engine hood.
- 2) Disconnect connector of horn.
- 3) Remove the horn.

#### **Tightening torque:**

$18\pm 5$  N·m ( $1.8\pm 0.5$  kg·m,  $13.0\pm 3.6$  ft·lb)

#### **CAUTION:**

After installing horn, connect connector, fit firmly wiring harness to prevent from disconnecting due to vibration.

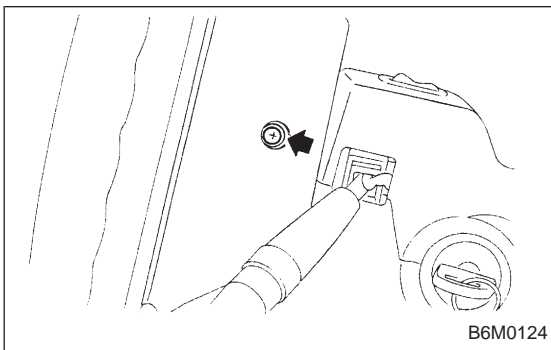

#### 2. HORN SWITCH (HORN PAD)

- 1) Remove screw which secures horn switch (steering pad) to the base of steering wheel.
- 2) Remove horn switch (steering pad) from steering wheel while disconnecting connector.

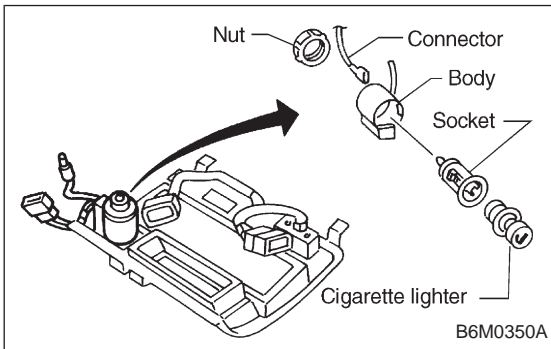

#### 3. CIGARETTE LIGHTER

- 1) Remove center panel from instrument panel. <Ref. to 5-4 [W1A0].>
- 2) Disconnect connector from cigarette lighter.
- 3) Turn illumination socket 45° counterclockwise and remove it.
- 4) Loosen nut, and then remove cigarette lighter body.

#### **CAUTION:**

● Align socket with cutout portion of instrument panel during installation.

● In case of replacing cigarette lighter, use genuine part only and always replace both plug and socket combination.

**B: INSPECTION****1. HORN SWITCH**

Ensure that horn switch is free from the following defects:

- 1) Burned or shorted contacts
- 2) Broken or weak spring
- 3) Damaged harness
- 4) Worn or corroded mating surface of horn plate

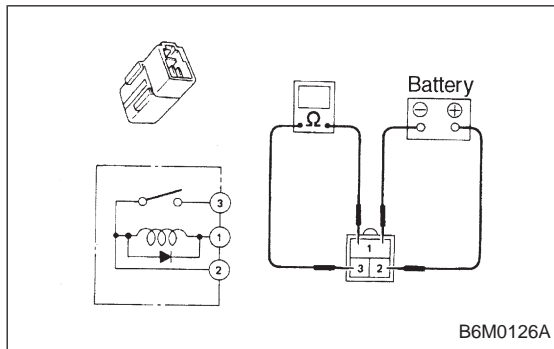
**2. HORN RELAY**

Check continuity between terminals as indicated in table below, when connecting the battery to terminals No. 1 and No. 2.

When current flows.	Between terminals No. 2 and No. 3	Continuity exists.
When current does not flow.	Between terminals No. 2 and No. 3	Continuity does not exist.
	Between terminals No. 1 and No. 2	Continuity exists.

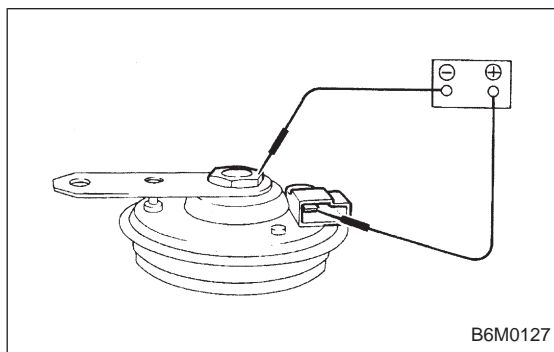
**3. HORN**

Make sure that horn sounds when battery voltage is applied between connector terminal and horn body.

**4. CIGARETTE LIGHTER**

- 1) Remove plug. Then, check element's contact for wear, and element for accumulation of ashes, foreign particles, etc.
- 2) Check element for discontinuity.
- 3) Remove socket and clean element. Then, check for wear or foreign particles on element's contact and mating surface.
- 4) Ensure that cigarette lighter returns within 20 seconds after it is turned to ON.

**16. Power Window****A: REMOVAL AND INSTALLATION****1. MAIN SWITCH, SUB SWITCH AND POWER WINDOW MOTOR**

Refer to 5-2 [W2A2] as for removal and installation of power window main switch, sub switch and motor.

**NOTE:**

To remove the power window motor, it is necessary to disassemble the door component parts.