

1. MECHANICAL APPLICATION TYPE

1) While pushing release lever ③ to pivot and twisting it to both sides, fit retainer spring ⑤ onto the constricted portion of pivot.

NOTE:

Confirm that retainer spring is securely fitted by observing it through the main case hole.

- 2) Install release bearing ⑥ and fasten it with two clips ②.
- 3) Install release lever seal ④.

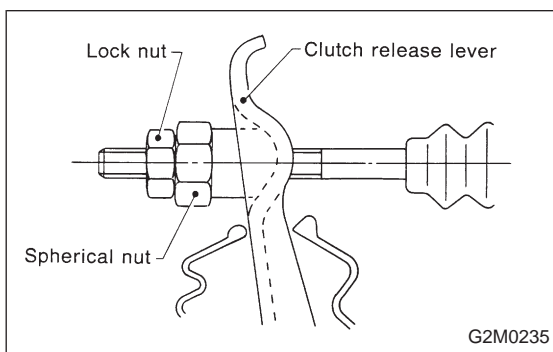

4) After remounting engine and transmission on body, make adjustment of the clutch release lever end play.

CAUTION:

Take care not to twist the cable during adjustment.

5) Install release lever return spring (Models without hill holder only).

NOTE:

Hook up the return spring to right side hole of the release lever.

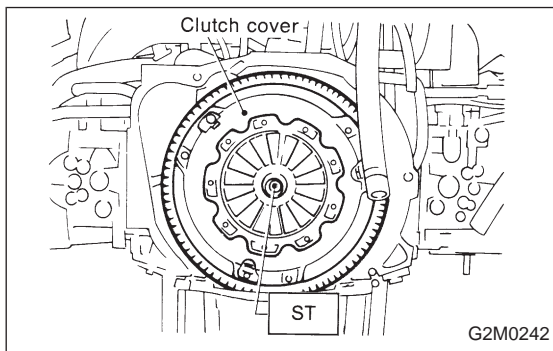

4. Clutch Disc and Cover

A: REMOVAL

- 1) Install ST on flywheel.
ST 498497100 CRANKSHAFT STOPPER
- 2) Remove clutch cover and clutch disc.

CAUTION:

- Take care not to allow oil on the clutch disc facing.
- Do not disassemble either clutch cover or clutch disc.

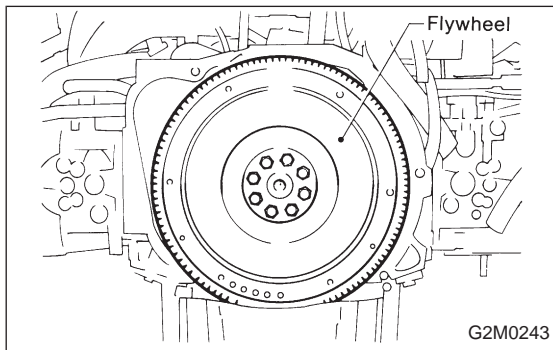

3) Remove flywheel.

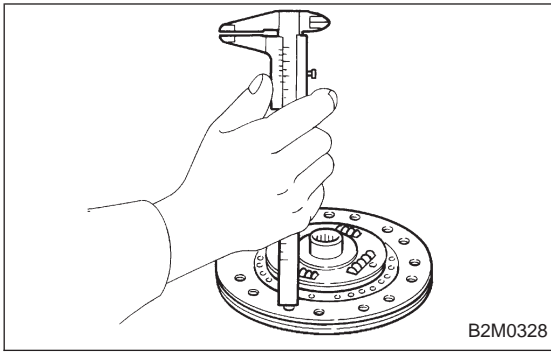
**B: INSPECTION****1. CLUTCH DISC**

1) Facing wear

Measure the depth of rivet head from the surface of facing. Replace if facings are worn locally or worn down to less than the specified value.

Depth of rivet head:**Standard value**

1.3 — 1.9 mm (0.051 — 0.075 in)

Limit of sinking

0.3 mm (0.012 in)

CAUTION:

Do not wash clutch disc with any cleaning fluid.

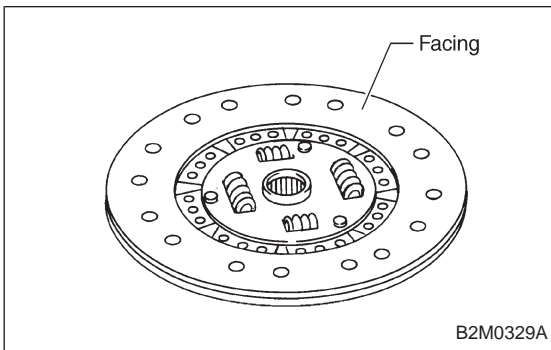

2) Hardened facing

Correct by using emery paper or replace.

3) Oil soakage on facing

Replace clutch disc and inspect transmission front oil seal, transmission case mating surface, engine rear oil seal and other points for oil leakage.

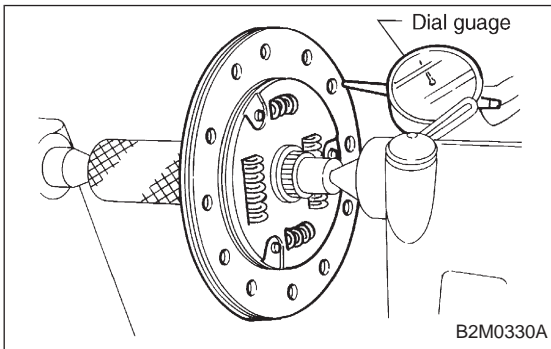

4) Deflection on facing

If deflection exceeds the specified value at the outer circumference of facing, repair or replace.

Limit for deflection:

1.0 mm (0.039 in) at R = 107 mm (4.21 in)

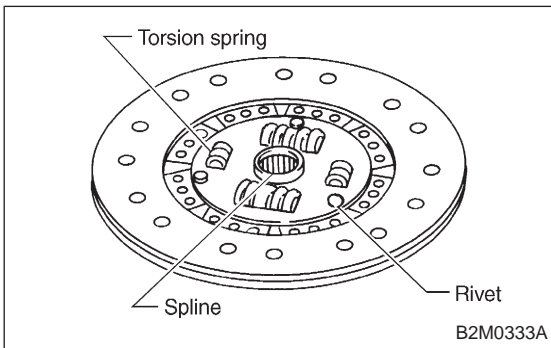

5) Worn spline, loose rivets and torsion spring failure

Replace defective parts.

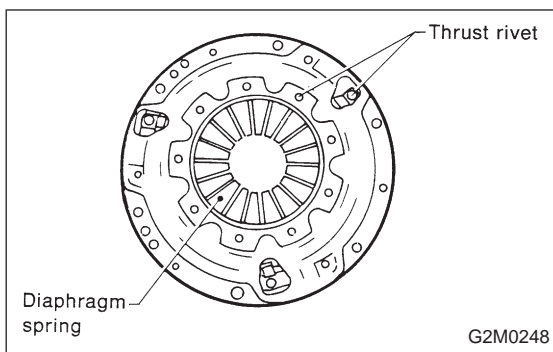

2. CLUTCH COVER

Visually check for the following items without disassembling, and replace or repair if defective.

- 1) Loose thrust rivet.
- 2) Damaged or worn bearing contact area at center of diaphragm spring.

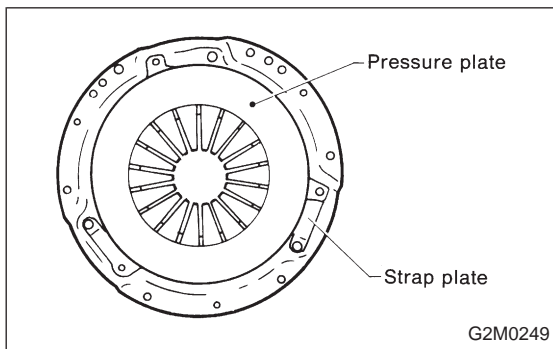

- 3) Damaged or worn disc contact surface of pressure plate.
- 4) Loose strap plate setting bolt.
- 5) Worn diaphragm sliding surface.

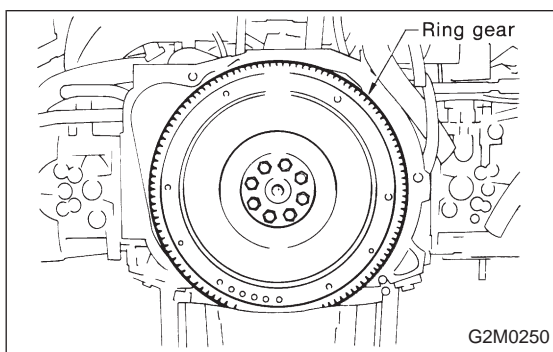

3. FLYWHEEL

CAUTION:

Since this bearing is grease sealed and is of a nonlubrication type, do not wash with gasoline or any solvent.

- 1) Damage of facing and ring gear
If defective, replace flywheel.

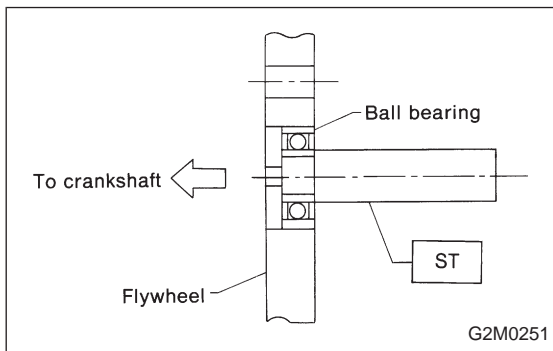

- 2) Smoothness of rotation

Rotate ball bearing applying pressure in thrust direction.

If noise or excessive play is noted, replace ball bearing as follows:

- (1) Drive out ball bearing from flywheel.
- (2) Press bearing into flywheel until bearing end surface is flush with clutch disc contact surface of flywheel.
Do not press inner race.

ST 899754112 SNAP RING PRESS

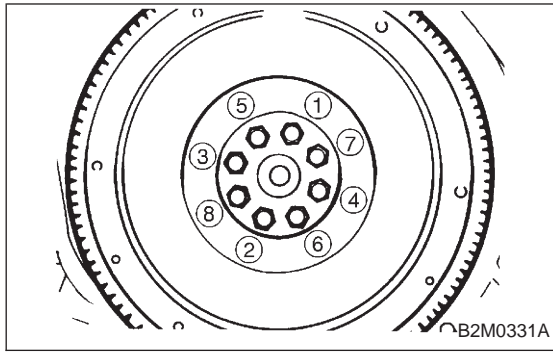
**C: INSTALLATION**

- 1) Install flywheel.
- 2) Install ST, and tighten the flywheel attaching bolts to the specified torque.

ST 498497100 CRANKSHAFT STOPPER

Tightening torque:

$72 \pm 3 \text{ N}\cdot\text{m}$ ($7.3 \pm 0.3 \text{ kg}\cdot\text{m}$, $52.8 \pm 2.2 \text{ ft}\cdot\text{lb}$)

NOTE:

Tighten flywheel installing bolts gradually. Each bolt should be tightened to the specified torque in a crisscross fashion.

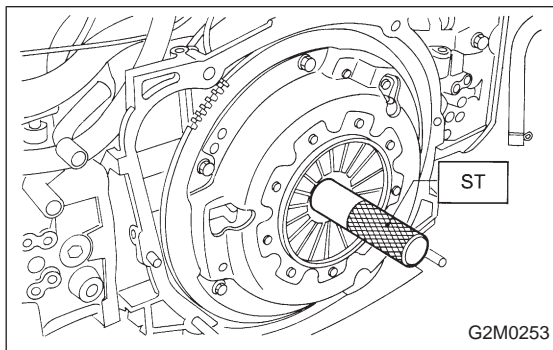
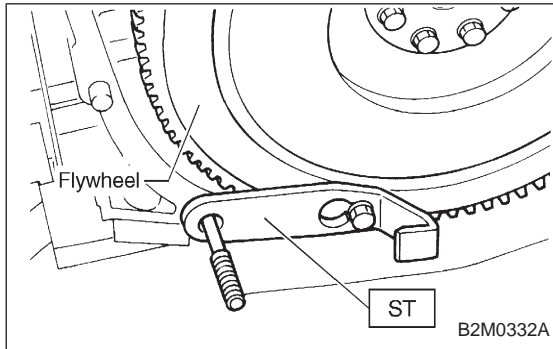

- 3) Insert ST into the clutch disc and install them on the flywheel by inserting the ST end into the pilot bearing.

ST 499747100 CLUTCH DISC GUIDE

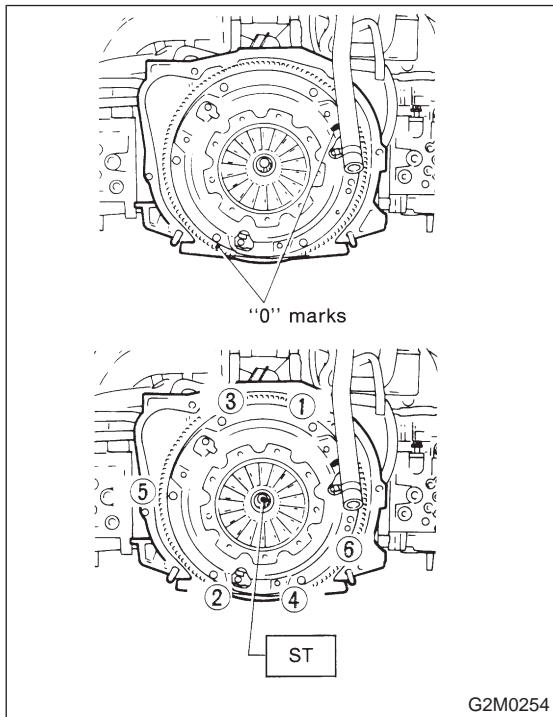

- 4) Install clutch cover on flywheel and tighten bolts to the specified torque.

NOTE:

- When installing the clutch cover on the flywheel, position the clutch cover so that there is a gap of 120° or more between "0" marks on the flywheel and clutch cover. ("0" marks indicate the directions of residual unbalance.)
- Note the front and rear of the clutch disc when installing.
- Tighten clutch cover installing bolts gradually. Each bolt should be tightened to the specified torque in a crisscross fashion.

Tightening torque:

$15.7 \pm 1.5 \text{ N}\cdot\text{m}$ ($1.6 \pm 0.15 \text{ kg}\cdot\text{m}$, $11.6 \pm 1.1 \text{ ft}\cdot\text{lb}$)

- 5) Remove ST.

ST 499747100 CLUTCH DISC GUIDE