

**1. On-Car Service****A: DRAINING OF ENGINE COOLANT**

1) Lift-up the vehicle.

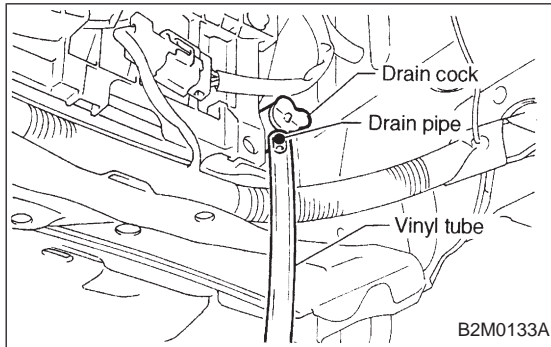

2) Fit vinyl tube to drain pipe.

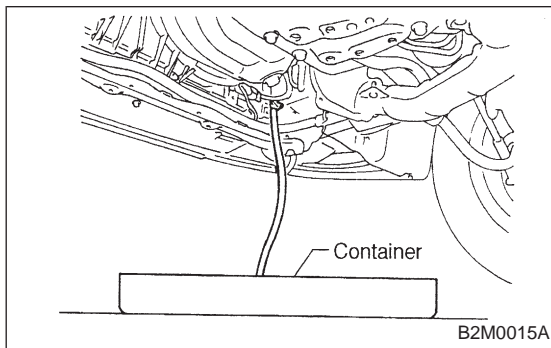

3) Loosen drain cock to drain engine coolant into container.

**NOTE:**

Remove radiator cap so that engine coolant will drain faster.

**B: FILLING OF ENGINE COOLANT**

1) Remove air vent plug from radiator.

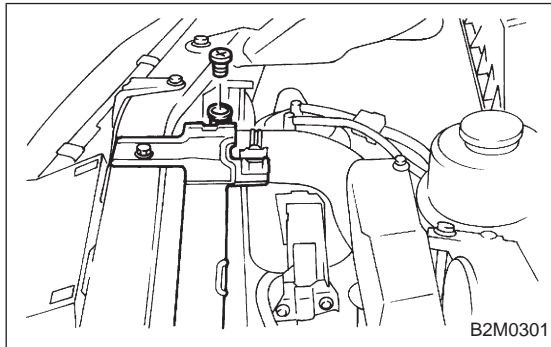

2) Fill engine coolant into radiator up to filler neck position.

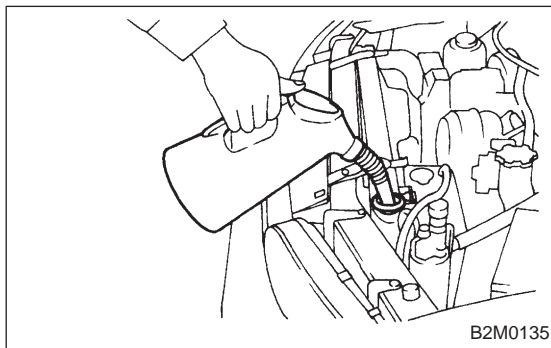

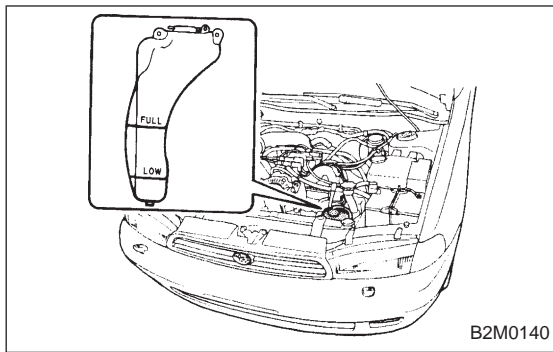

B2M0140

3) Fill engine coolant into reservoir tank up to upper level.

4) Attach radiator cap and reservoir tank cap properly.

5) Install air vent plug.

6) Warm-up engine completely for more than five minutes at 2,000 to 3,000 rpm.

7) Stop engine and wait until temperature drops to a safe level.

8) If engine coolant level drops in radiator, add engine coolant to filler neck position.

9) If engine coolant level drops from upper level of reservoir tank, add engine coolant to upper level.

10) Attach radiator cap and reservoir tank cap properly.

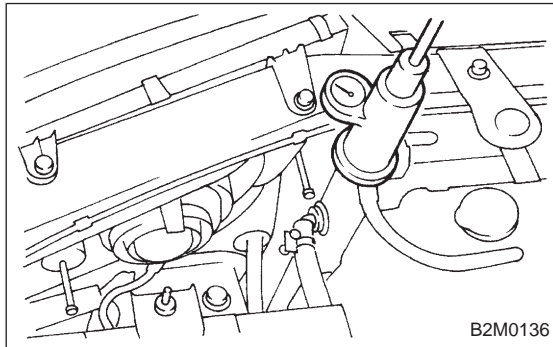

B2M0136

### C: CHECKING OF COOLING SYSTEM

1) Remove radiator cap, top off radiator, and attach tester to radiator in place of cap.

2) Apply a pressure of 157 kPa (1.6 kg/cm<sup>2</sup>, 23 psi) to radiator to check if:

(1) Engine coolant leaks at/around radiator.

(2) Engine coolant leaks at/around hoses or connections.

#### CAUTION:

- Engine should be off.
- Wipe engine coolant from check points in advance.
- Be careful to prevent engine coolant from spurting out when removing tester.
- Be careful also not to deform filler neck of radiator when installing or removing tester.