

2. Radiator Main Fan

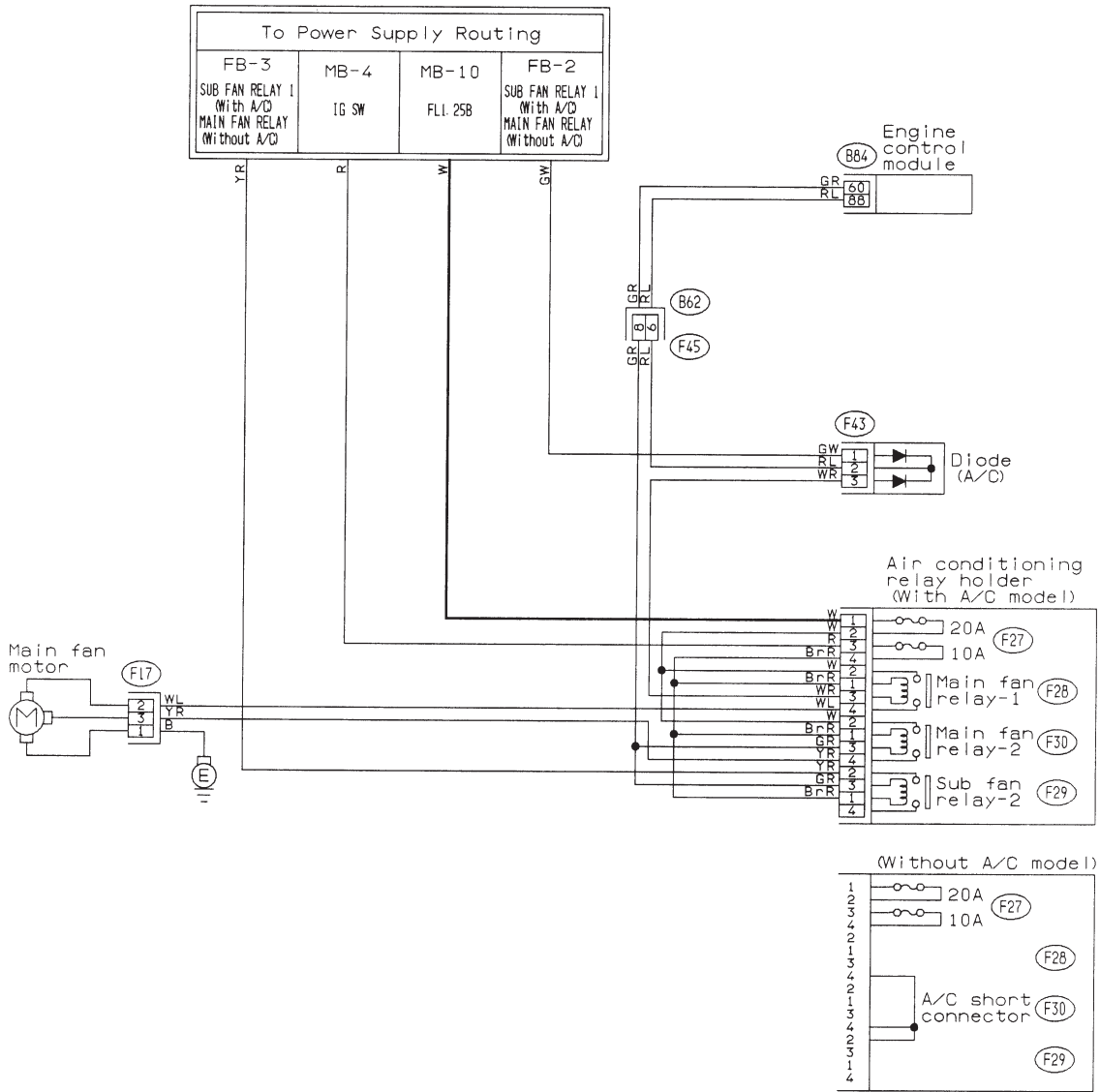

(F43) (Orange)

(F17) (Black)



(F45)

(B84) (Dark gray)

(F27) (F28) (F29) (F30) (F31)

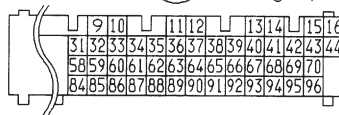

A/C relay holder (Black)

A: OPERATION (WITHOUT A/C MODEL)

CONDITION:

- Engine coolant temperature is above 95°C (203°F).

TROUBLE SYMPTOM:

- Radiator main fan does not operate under the above condition.

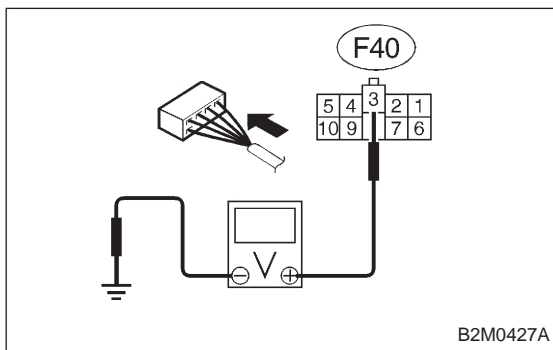
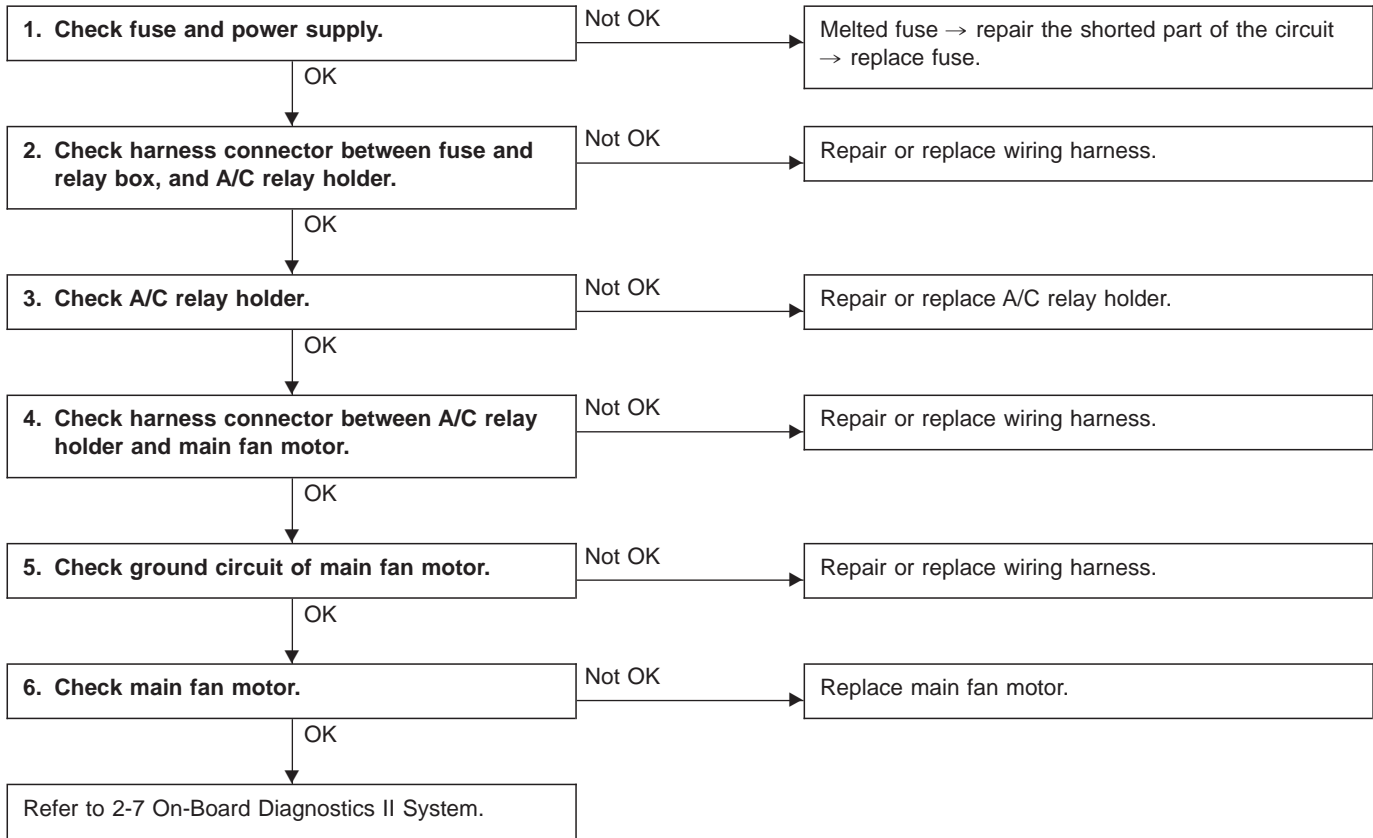

1. CHECK FUSE AND POWER SUPPLY.

- 1) Check fuse No. 13.
- 2) Turn ignition switch to ACC.
- 3) Measure voltage between fuse and relay box, and body.

Connector & terminal / Specified voltage:
(F40) No. 3 — Body / 10 V, or more

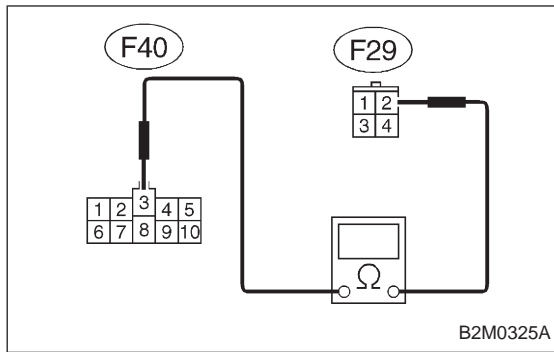

2. CHECK HARNESS CONNECTOR BETWEEN FUSE AND RELAY BOX, AND A/C RELAY HOLDER.

- 1) Turn ignition switch to OFF.
- 2) Disconnect connectors from fuse and relay box, and A/C relay holder.
- 3) Measure resistance of harness connector between fuse and relay box, and A/C relay holder.

Connector & terminal / Specified resistance:
(F40) No. 3 — (F29) No. 2 / 10 Ω, max.

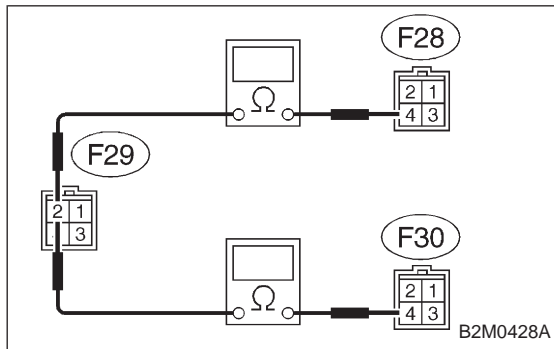

3. CHECK A/C RELAY HOLDER.

- 1) Disconnect connector from A/C relay holder.
- 2) Measure resistance between terminals of A/C relay holder.

Connector & terminal / Specified resistance:
(F29) No. 2 — (F28) No. 4 / 10 Ω, max.
(F29) No. 2 — (F30) No. 4 / 10 Ω, max.

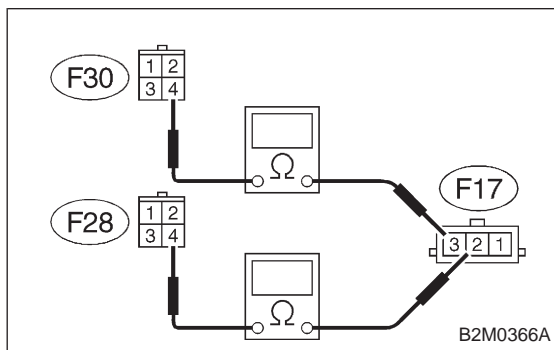

4. CHECK HARNESS CONNECTOR BETWEEN A/C RELAY HOLDER AND MAIN FAN MOTOR.

- 1) Disconnect connectors from A/C relay holder and main fan motor.
- 2) Measure resistance of harness connector between A/C relay holder and main fan motor.

Connector & terminal / Specified resistance:
(F28) No. 4 — (F17) No. 2 / 10 Ω, max.
(F30) No. 4 — (F17) No. 3 / 10 Ω, max.

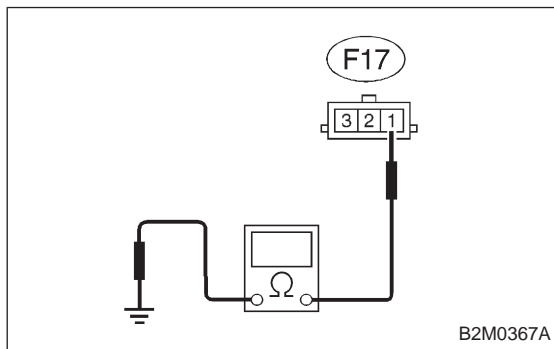

5. CHECK GROUND CIRCUIT OF MAIN FAN MOTOR.

Measure resistance between main fan motor connector and body.

Connector & terminal / Specified resistance:
(F17) No. 1 — Body / 10 Ω, max.

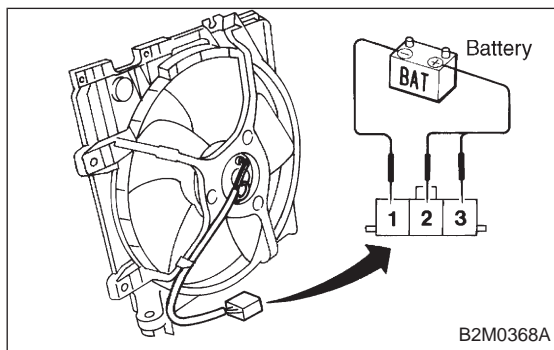

6. CHECK MAIN FAN MOTOR.

- 1) Disconnect connector from main fan motor.
- 2) Connect battery positive (+) terminal to terminals No. 2 and No. 3, and connect terminal No. 1 to ground. Ensure that fan rotates.

B: LO MODE OPERATION (WITH A/C MODEL)**CONDITION:**

Condition (1) :

- Engine coolant temperature is below 89°C (192°F).
- A/C switch is turned ON.
- Vehicle speed is below 10 km/h (6 MPH).

Condition (2) :

- Engine coolant temperature is above 95°C (203°F).
- A/C switch is turned OFF.
- Vehicle speed is below 10 km/h (6 MPH).

TROUBLE SYMPTOM:

- Radiator main fan does not rotate at LO speed under conditions (1) and (2) above.

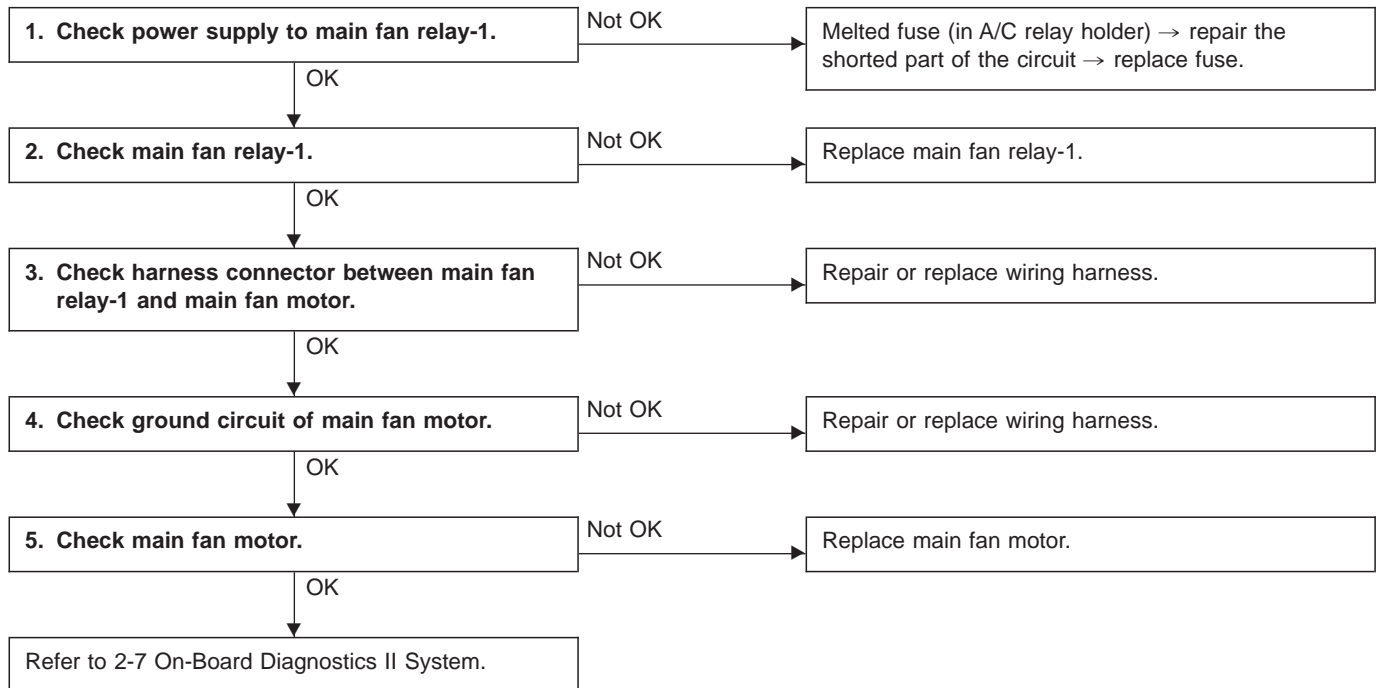

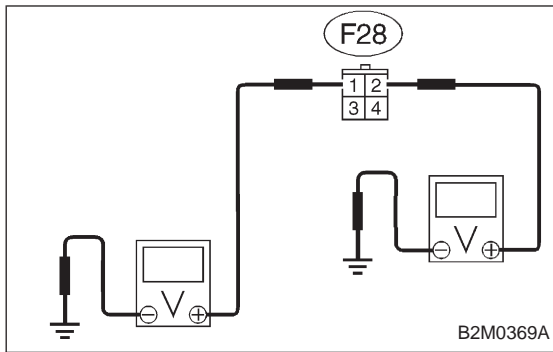

1. CHECK POWER SUPPLY TO MAIN FAN RELAY-1.

- 1) Turn ignition switch to OFF.
- 2) Disconnect connector from A/C relay holder.
- 3) Measure voltage between A/C relay holder connector and body.

Connector & terminal / Specified voltage:

(F28) No. 2 — Body / 10 V, or more

(F28) No. 1 — Body / 1 V, max.

- 4) Turn ignition switch to ON.
- 5) Measure voltage between A/C relay holder connector and body.

Connector & terminal / Specified voltage:

(F28) No. 1 — Body / 10 V, or more

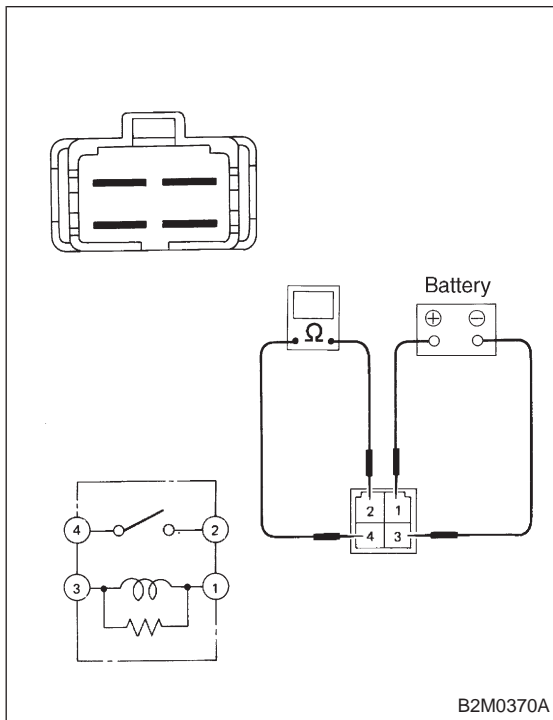

2. CHECK MAIN FAN RELAY-1.

- 1) Turn ignition switch to OFF.
- 2) Remove main fan relay-1 from A/C relay holder.
- 3) Check continuity between terminals (indicated in table below) when terminal (1) is connected to battery and terminal (3) is grounded.

When current flows.	Between terminals (2) and (4)	Continuity exists.
When current does not flow.	Between terminals (2) and (4)	Continuity does not exist.
	Between terminals (1) and (3)	Continuity exists.

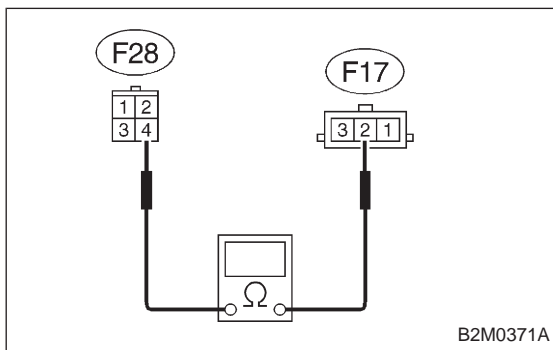

3. CHECK HARNESS CONNECTOR BETWEEN MAIN FAN RELAY-1 AND MAIN FAN MOTOR.

- 1) Disconnect connectors from main fan relay-1 and main fan motor.
- 2) Measure resistance of harness connector between main fan relay-1 and main fan motor.

Connector & terminal / Specified resistance:

(F28) No. 4 — (F17) No.2 / 10 Ω, max.

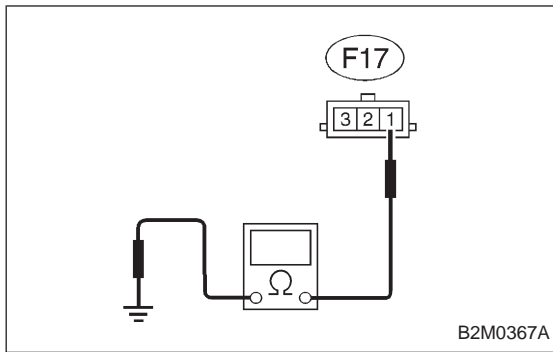

4. CHECK GROUND CIRCUIT OF MAIN FAN MOTOR.

Measure resistance between main fan motor connector and body.

Connector & terminal / Specified resistance:
(F17) No. 1 — Body / 10 Ω, max.

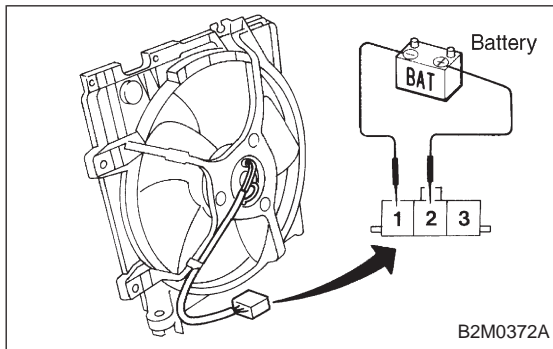

5. CHECK MAIN FAN MOTOR.

- 1) Disconnect connector from main fan motor.
- 2) Connect battery positive (+) terminal to terminal No. 2 and connect terminal No. 1 to ground. Ensure that fan rotates at LO speed.

C: HI MODE OPERATION (WITH A/C MODEL)**CONDITION:**

Condition (1) :

- Engine coolant temperature is below 89°C (192°F).
- A/C switch is turned ON.
- Vehicle speed is over 20 km/h (12 MPH).

Condition (2) :

- Engine coolant temperature is above 95°C (203°F).
- A/C switch is turned OFF.
- Vehicle speed is over 20 km/h (12 MPH).

Condition (3) :

- Engine coolant temperature is above 95°C (203°F).
- A/C switch is turned ON.

TROUBLE SYMPTOM:

- Radiator main fan does not rotate at HI speed under conditions (1), (2) and (3) above.

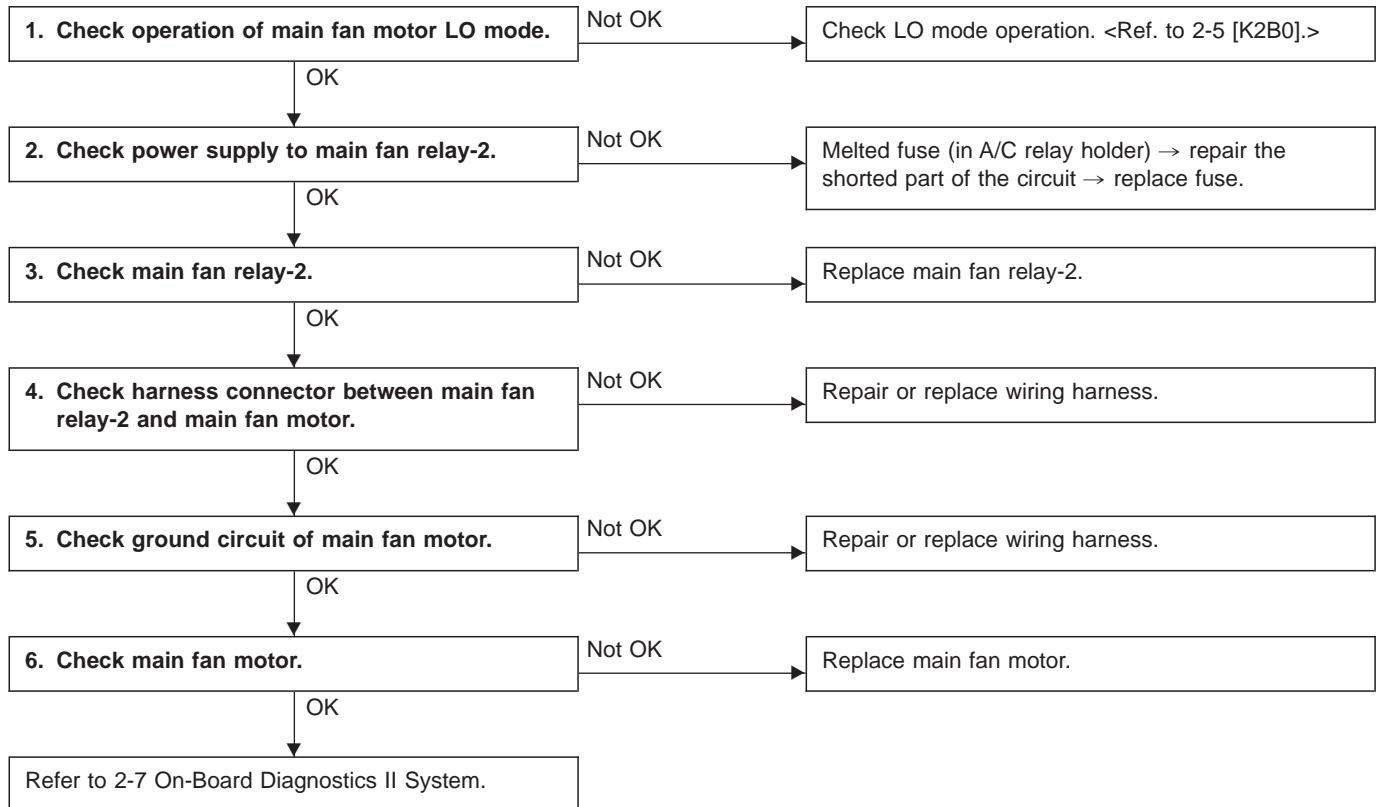

1. CHECK OPERATION OF MAIN FAN MOTOR LO MODE.

Check that radiator main fan rotates at LO speed under each condition described under LO mode operation. <Ref. to 2-5 [K2B0].>

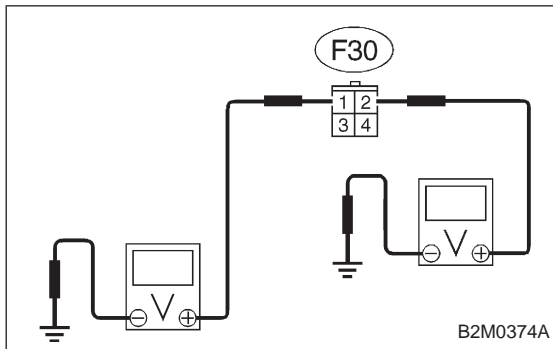

2. CHECK POWER SUPPLY TO MAIN FAN RELAY-2.

- 1) Turn ignition switch to OFF.
- 2) Disconnect connector from A/C relay holder.
- 3) Measure voltage between A/C relay holder connector and body.

Connector & terminal / Specified voltage:

(F30) No. 2 — Body / 10 V, or more

(F30) No. 1 — Body / 1 V, max.

- 4) Turn ignition switch to ON.
- 5) Measure voltage between A/C relay holder connector and body.

Connector & terminal / Specified voltage:

(F30) No. 1 — Body / 10 V, or more

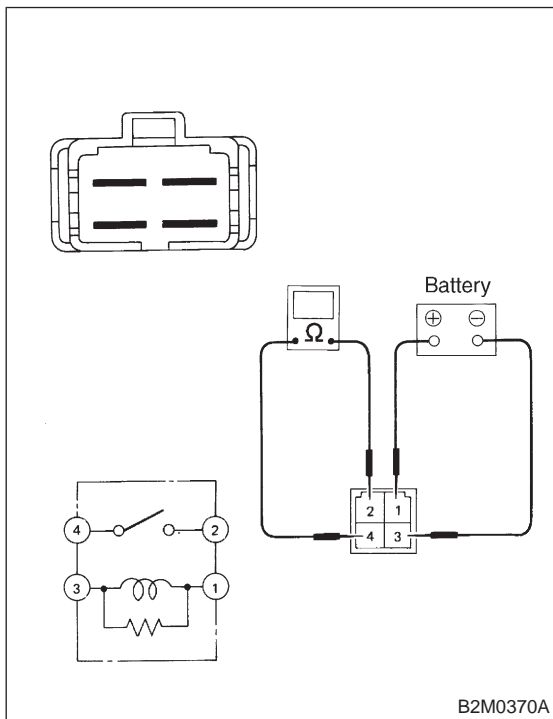

3. CHECK MAIN FAN RELAY-2.

- 1) Turn ignition switch to OFF.
- 2) Remove main fan relay-2 from A/C relay holder.
- 3) Check continuity between terminals (indicated in table below) when terminal (1) is connected to battery and terminal (3) is grounded.

When current flows.	Between terminals (2) and (4)	Continuity exists.
When current does not flow.	Between terminals (2) and (4)	Continuity does not exist.
	Between terminals (1) and (3)	Continuity exists.

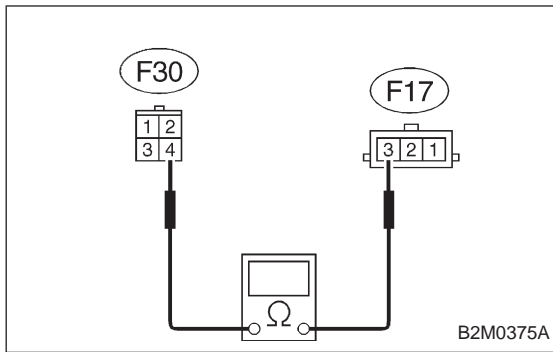

4. CHECK HARNESS CONNECTOR BETWEEN MAIN FAN RELAY-2 AND MAIN FAN MOTOR.

- 1) Disconnect connectors from main fan relay-2 and main fan motor.
- 2) Measure resistance of harness connector between main fan relay-2 and main fan motor.

Connector & terminal / Specified resistance:

(F30) No. 4 — (F17) No. 3 / 10 Ω, max.

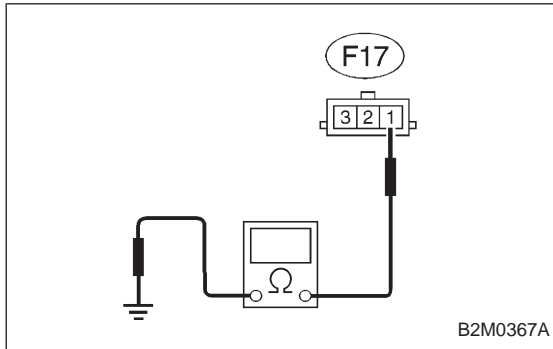

5. CHECK GROUND CIRCUIT OF MAIN FAN MOTOR.

Measure resistance between main fan motor connector and body.

Connector & terminal / Specified resistance:

(F17) No. 1 — Body / 10 Ω, max.

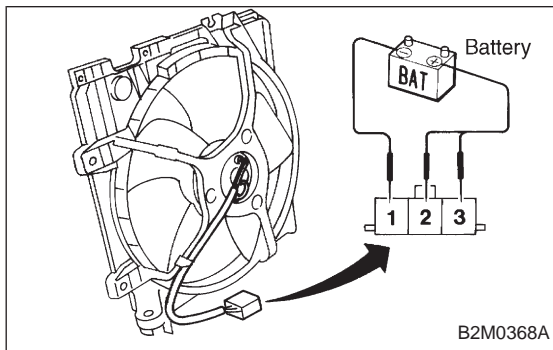

6. CHECK MAIN FAN MOTOR.

- 1) Disconnect connector from main fan motor.
- 2) Connect battery positive (+) terminal to terminals No. 2 and No. 3, and connect terminal No. 1 to ground. Ensure that fan rotates at HI speed.