

1. Lubrication System

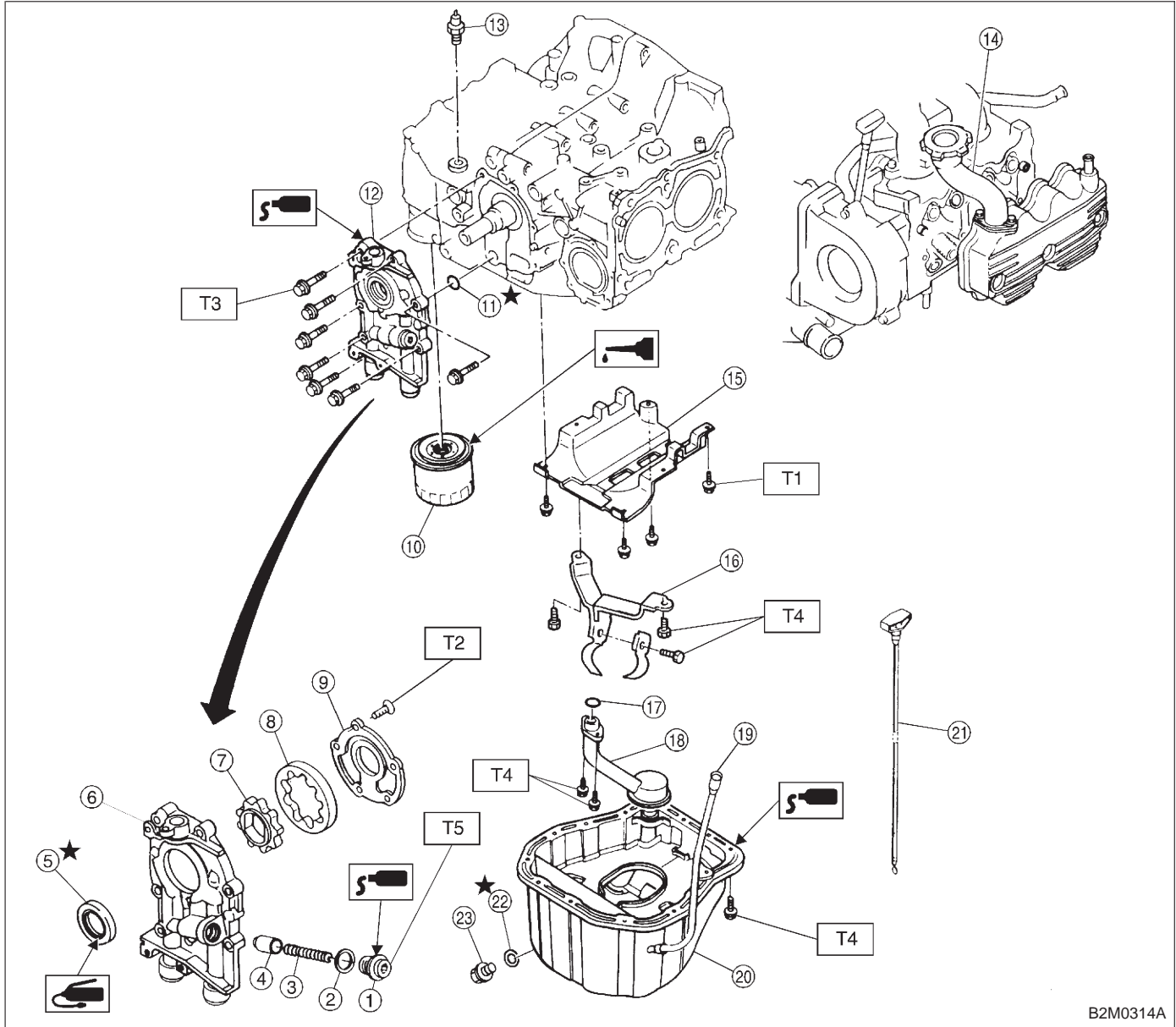

B2M0314A

- ① Plug
- ② Washer
- ③ Relief valve spring
- ④ Relief valve
- ⑤ Oil seal
- ⑥ Oil pump case
- ⑦ Inner rotor
- ⑧ Outer rotor
- ⑨ Oil pump cover
- ⑩ Oil filter
- ⑪ O-ring
- ⑫ Oil pump ASSY
- ⑬ Oil pressure switch
- ⑭ Oil filler duct

- ⑮ Baffle plate
- ⑯ Oil strainer stay
- ⑰ O-ring
- ⑱ Oil strainer
- ⑲ Oil level gauge guide
- ⑳ Oil pan
- ㉑ Oil level gauge
- ㉒ Washer
- ㉓ Drain plug

Tightening torque: N-m (kg-m, ft-lb)

T1: 5 (0.5, 3.6)

T2: 5_{-0}^{+1} ($0.5_{-0}^{+0.1}$, $3.6_{-0}^{+0.7}$)

T3: 6.4 (0.65, 4.7)

T4: 9.8 (1.0, 7.0)

T5: 44.1 ± 3.4 (4.5 ± 0.35 , 32.5 ± 2.5)