

## 7. Cylinder Block

### A: REMOVAL

#### 1. RELATED PARTS

1) Remove timing belt, camshaft sprocket and related parts.

<Ref. to 2-3 [W3A1].>

2) Remove intake manifold and cylinder head.

<Ref. to 2-3 [W6A0].>

#### 2. OIL PUMP AND ENGINE COOLANT PUMP

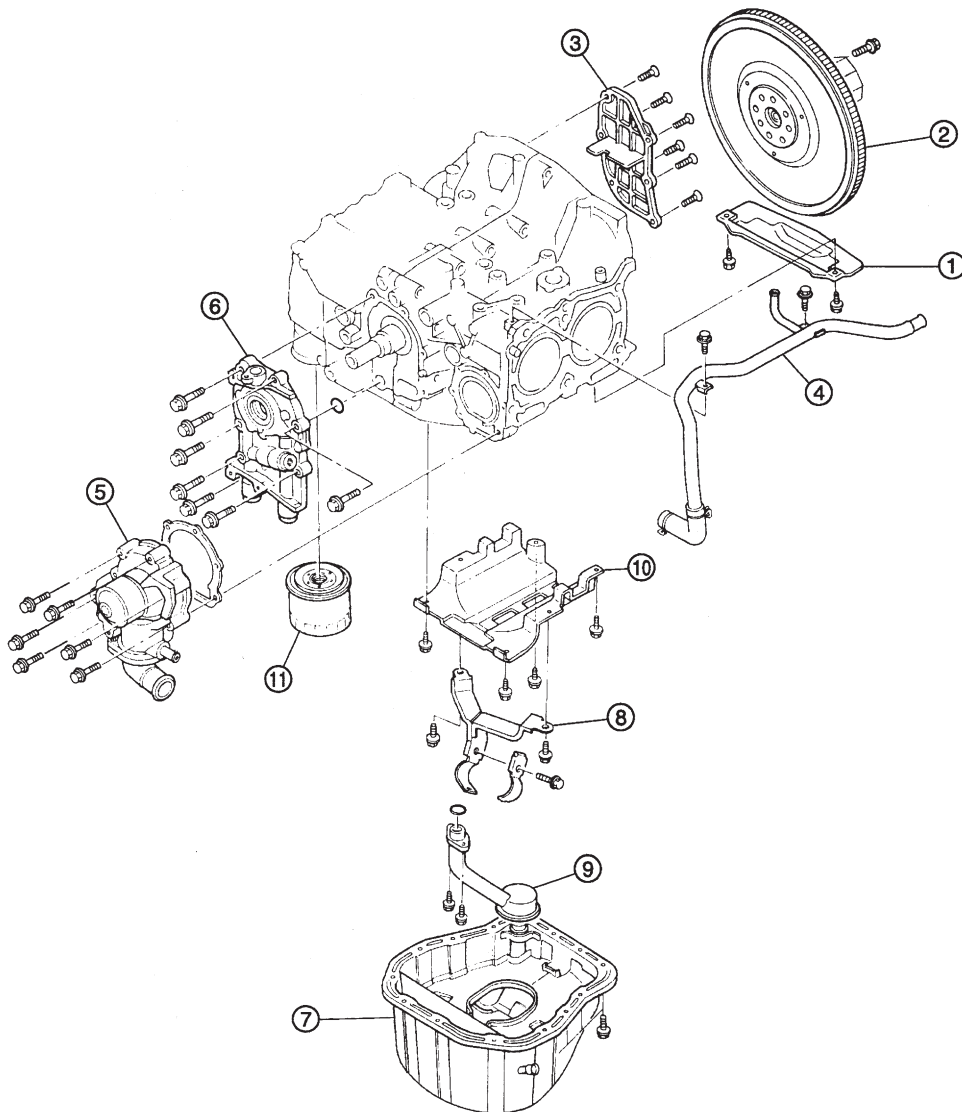

B2M0124A

1) Remove housing cover.

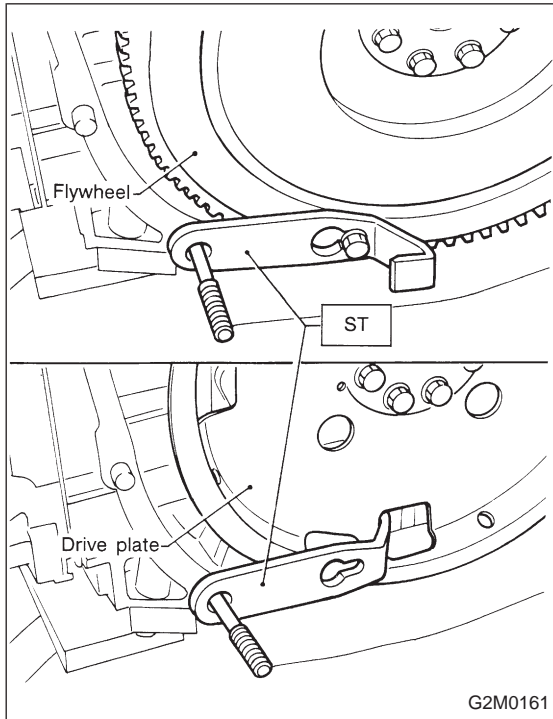

2) Remove flywheel or drive plate.  
To lock crankshaft use ST.

ST 498497100 CRANKSHAFT STOPPER

3) Remove oil separator cover.

4) Remove engine coolant pipe.

5) Remove engine coolant pump.

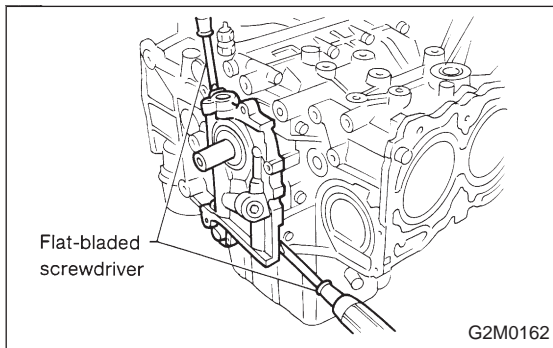

6) Remove oil pump from cylinder block.

Use a flat-bladed screwdriver as shown in Figure when removing oil pump.

**CAUTION:**

**Be careful not to scratch the mating surface of cylinder block and oil pump.**

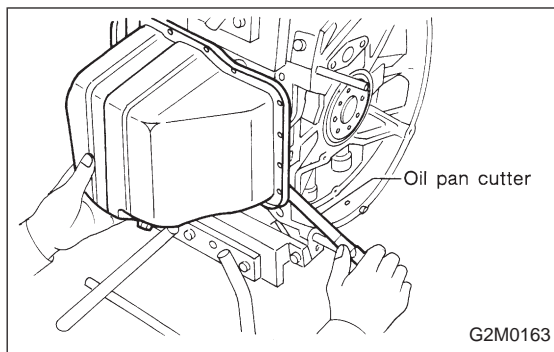

## 7) Removal of oil pan

- (1) Turn cylinder block with #2 and #4 piston sides facing upward.
- (2) Remove bolts which secure oil pan to cylinder block.
- (3) Insert an oil pan cutter blade between cylinder block-to-oil pan clearance and remove oil pan.

**CAUTION:**

**Do not use a screwdriver or similar tool in place of oil-pan cutter.**

8) Remove oil strainer stay.

9) Remove oil strainer.

10) Remove baffle plate.

11) Remove oil filter.

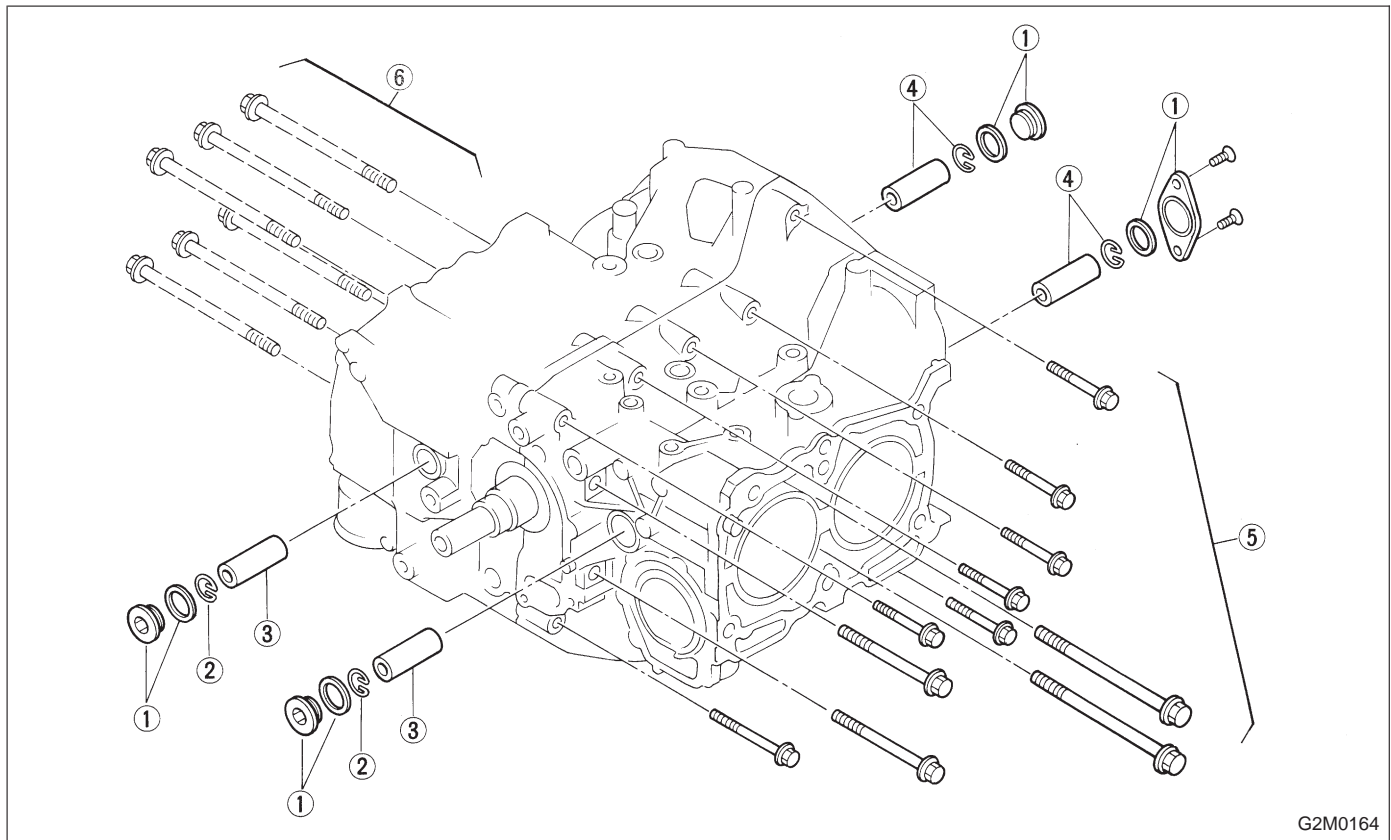
**B: DISASSEMBLY****1. PISTON PIN AND CYLINDER BLOCK CONNECTING BOLT**

- 1) Remove service hole cover and service hole plugs using hexagon wrench (14 mm).

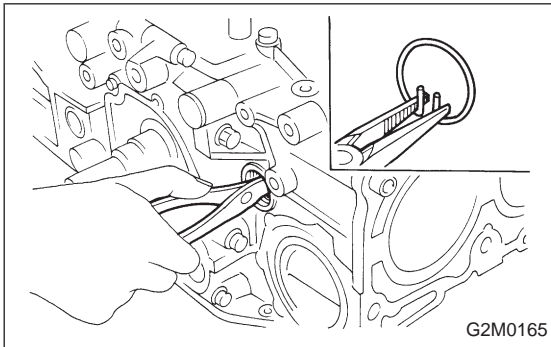

- 2) Rotate crankshaft to bring #1 and #2 pistons to bottom dead center position, then remove piston circlip through service hole of #1 and #2 cylinders.

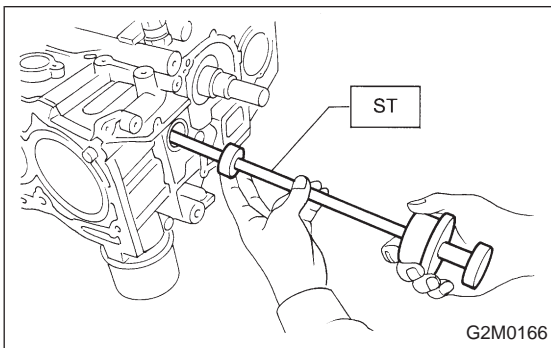

- 3) Draw out piston pin from #1 and #2 pistons by using ST.  
ST 499097500 PISTON PIN REMOVER

**CAUTION:**  
Be careful not to confuse original combination of piston, piston pin and cylinder.

- 4) Similarly remove piston pins from #3 and #4 pistons by using ST.

- 5) Remove bolts which connect cylinder block on the side of #2 and #4 cylinders.
- 6) Back off bolts which connect cylinder block on the side of #1 and #3 cylinders two or three turns.

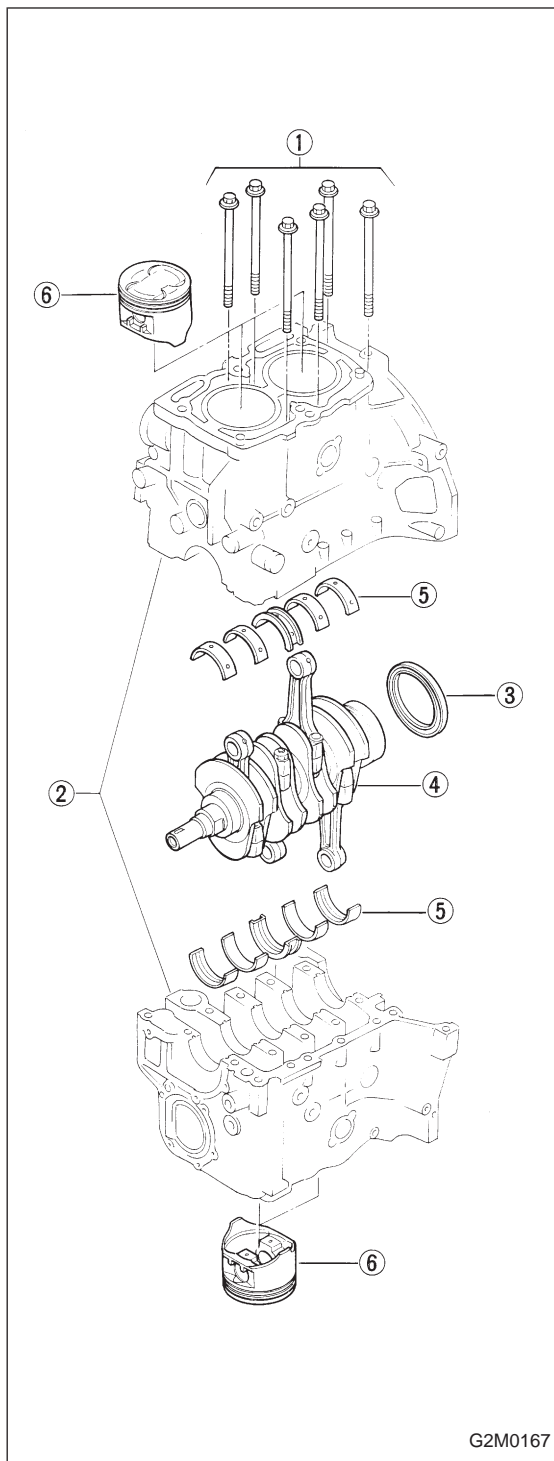

## 2. CYLINDER BLOCK

1) Set up cylinder block so that #1 and #3 cylinders are on the upper side, then remove cylinder block connecting bolts.

2) Separate left-hand and right-hand cylinder blocks.

### CAUTION:

**When separating cylinder block, do not allow the connecting rod to fall and damage the cylinder block.**

3) Remove rear oil seal.

4) Remove crankshaft together with connecting rod.

5) Remove crankshaft bearings from cylinder block using hammer handle.

### CAUTION:

**Do not confuse combination of crankshaft bearings. Press bearing at the end opposite to locking lip.**

6) Draw out each piston from cylinder block using wooden bar or hammer handle.

### CAUTION:

**Do not confuse combination of piston and cylinder.**

## 3. CRANKSHAFT AND PISTON

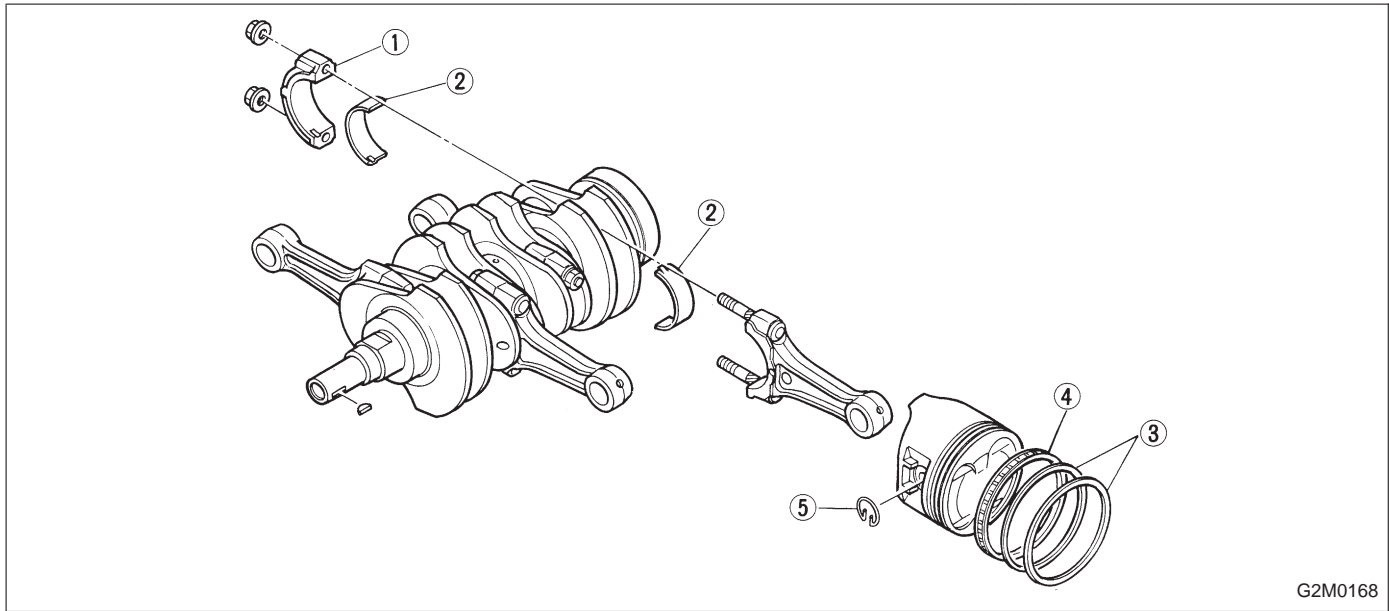

- 1) Remove connecting rod cap.
- 2) Remove connecting rod bearing.

**CAUTION:**

**Arrange removed connecting rod, connecting rod cap and bearing in order to prevent confusion.**

- 3) Remove piston rings using the piston ring expander.
- 4) Remove the oil ring by hand.

**CAUTION:**

**Arrange the removed piston rings in good order to prevent confusion.**

- 5) Remove circlip.

**C: INSPECTION****1. CYLINDER BLOCK**

- 1) Check for cracks and damage visually. Especially, inspect important parts by means of red lead check.
- 2) Check the oil passages for clogging.
- 3) Inspect crankcase surface that mates with cylinder head for warping by using a straight edge, and correct by grinding if necessary.

**Warping limit:**

**0.05 mm (0.0020 in)**

**Grinding limit:**

**0.1 mm (0.004 in)**

**Standard height of cylinder block:**

**201.0 mm (7.91 in)**

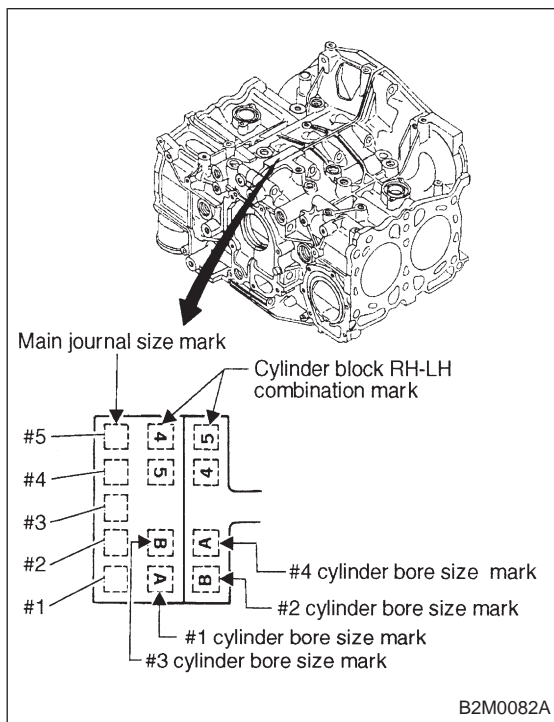
**2. CYLINDER AND PISTON**

- 1) The cylinder bore size is stamped on the cylinder block's front upper surface.

**NOTE:**

Standard sized pistons are classified into two grades, "A" and "B". These grades should be used as a guide line in selecting a standard piston.

**Standard diameter:**

**A: 96.905 — 96.915 mm (3.8151 — 3.8155 in)**

**B: 96.895 — 96.905 mm (3.8148 — 3.8151 in)**

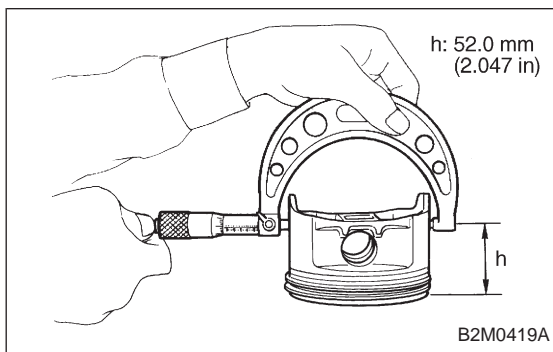
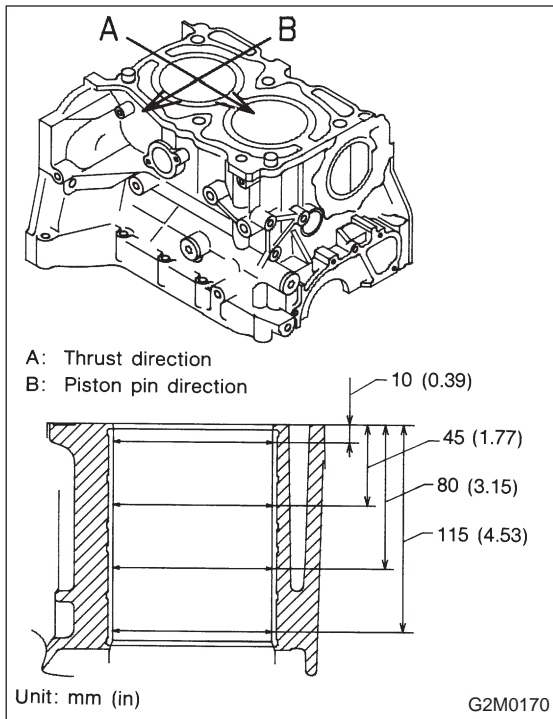

2) How to measure the inner diameter of each cylinder  
Measure the inner diameter of each cylinder in both the thrust and piston pin directions at the heights shown in the Figure, using a cylinder bore gauge.

**CAUTION:**

Measurement should be performed at a temperature 20°C (68°F).

**Taper:**

**Standard**

0.015 mm (0.0006 in)

**Limit**

0.050 mm (0.0020 in)

**Out-of-roundness:**

**Standard**

0.010 mm (0.0004 in)

**Limit**

0.050 mm (0.0020 in)

3) When piston is to be replaced due to general or cylinder wear, determine a suitable sized piston by measuring the piston clearance.

4) How to measure the outer diameter of each piston  
Measure the outer diameter of each piston at the height shown in the Figure. (Thrust direction)

**CAUTION:**

Measurement should be performed at a temperature of 20°C (68°F).

**Piston outer diameter:**

**Standard**

A: 96.885 — 96.895 mm (3.8144 — 3.8148 in)

B: 96.875 — 96.885 mm (3.8140 — 3.8144 in)

0.25 mm (0.0098 in) oversize

97.115 — 97.145 mm (3.8234 — 3.8246 in)

0.50 mm (0.0197 in) oversize

97.365 — 97.395 mm (3.8333 — 3.8344 in)

5) Calculate the clearance between cylinder and piston.

**CAUTION:**

Measurement should be performed at a temperature of 20°C (68°F).

**Cylinder to piston clearance at 20°C (68°F):**

**Standard**

0.010 — 0.030 mm (0.0004 — 0.0012 in)

**Limit**

0.050 mm (0.0020 in)



## 6) Boring and honing

- (1) If the value of taper, out-of-roundness, or cylinder-to-piston clearance measured exceeds the specified limit or if there is any damage on the cylinder wall, rebore it to use an oversize piston.

**CAUTION:**

**When any of the cylinders needs reboring, all other cylinders must be bored at the same time, and use oversize pistons. Do not perform boring on one cylinder only, nor use an oversize piston for one cylinder only.**

- (2) If the cylinder inner diameter exceeds the limit after boring and honing, replace the crankcase.

**CAUTION:**

**Immediately after reboring, the cylinder diameter may differ from its real diameter due to temperature rise. Thus, pay attention to this when measuring the cylinder diameter.**

**Limit of cylinder enlarging (boring):**

**0.5 mm (0.020 in)**

**3. PISTON AND PISTON PIN**

- 1) Check pistons and piston pins for damage, cracks, and wear and the piston ring grooves for wear and damage. Replace if defective.

- 2) Measure the piston-to-cylinder clearance at each cylinder as instructed in 2. CYLINDER AND PISTON [W7C2]. If any of the clearances is not to specification, replace the piston or bore the cylinder to use an oversize piston.

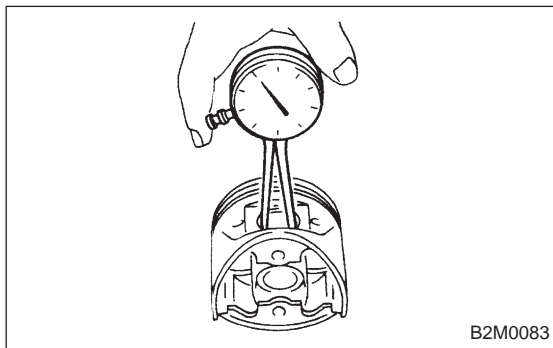

- 3) Make sure that piston pin can be inserted into the piston pin hole with a thumb at 20°C (68°F). Replace if defective.

**Standard clearance between piston pin and hole in piston:****Standard**

**0.004 — 0.010 mm (0.0002 — 0.0004 in)**

**Limit**

**0.020 mm (0.0008 in)**

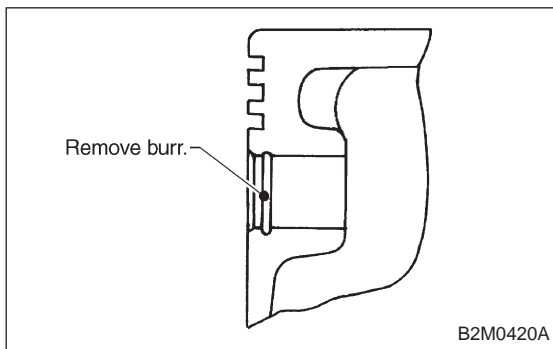
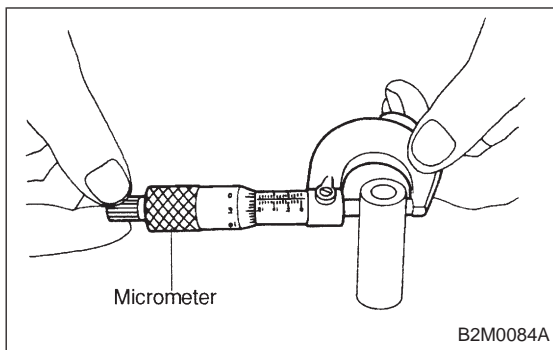

- 4) Check circlip installation groove on the piston for burr. If necessary, remove burr from the groove so that piston pin can lightly move.
- 5) Check piston pin circlip for distortion, cracks and wear.

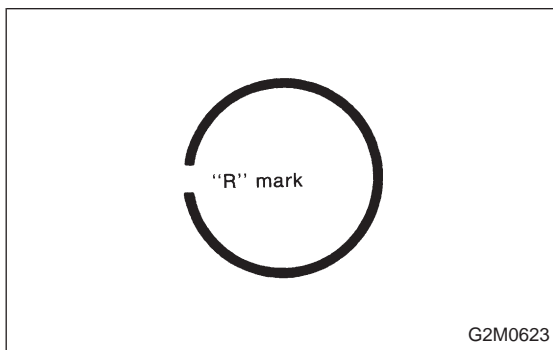

**4. PISTON RING**

- 1) If piston ring is broken, damaged, or worn, or if its tension is insufficient, or when the piston is replaced, replace piston ring with a new one of the same size as the piston.

**CAUTION:**

- "R" is marked on the end of the top and second rings. When installing the rings to the piston, face this mark upward.

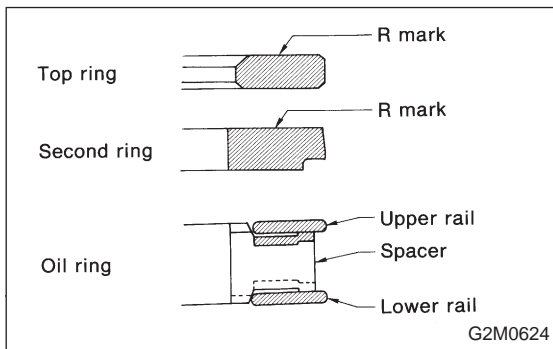

- The oil ring is a combined ring consisting of two rails and a spacer in between. When installing, be careful to assemble correctly.

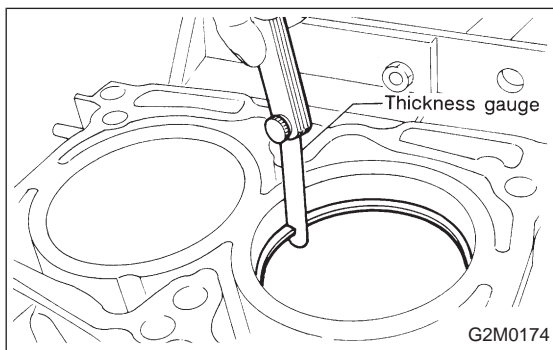

- 2) Squarely place piston ring and oil ring in cylinder, and measure the piston ring gap with a thickness gauge.
- Unit: mm (in)

		Standard	Limit
Piston ring gap	Top ring	0.20 — 0.35 (0.0079 — 0.0138)	1.0 (0.039)
	Second ring	0.20 — 0.50 (0.0079 — 0.0197)	1.0 (0.039)
	Oil ring rail	0.20 — 0.70 (0.0079 — 0.0276)	1.5 (0.059)

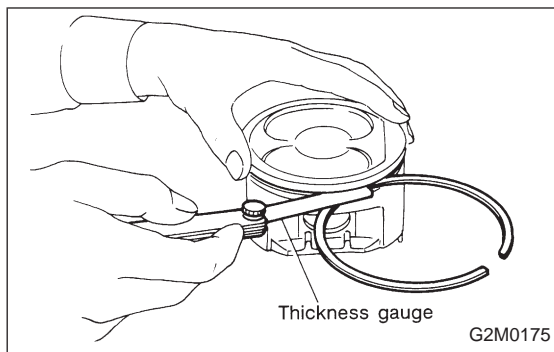

3) Measure the clearance between piston ring and piston ring groove with a thickness gauge.

**CAUTION:**

**Before measuring the clearance, clean the piston ring groove and piston ring.**

Unit: mm (in)

		Standard	Limit
Clearance between piston ring and piston ring groove	Top ring	0.040 — 0.080 (0.0016 — 0.0031)	0.15 (0.0059)
	Second ring	0.030 — 0.070 (0.0012 — 0.0028)	0.15 (0.0059)

## 5. CONNECTING ROD

1) Replace connecting rod, if the large or small end thrust surface is damaged.

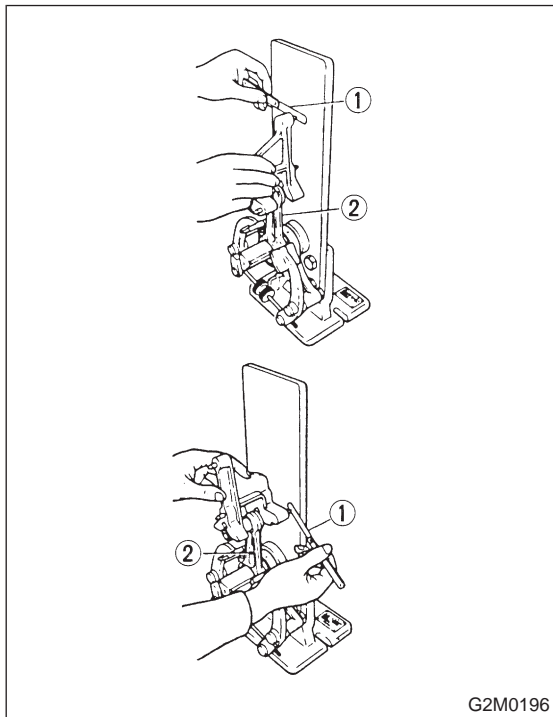

2) Check for bend or twist using a connecting rod aligner. Replace connecting rod if the bend or twist exceeds the limit.

**Limit of bend or twist per 100 mm (3.94 in) in length:  
0.10 mm (0.0039 in)**

- ① Thickness gauge
- ② Connecting rod

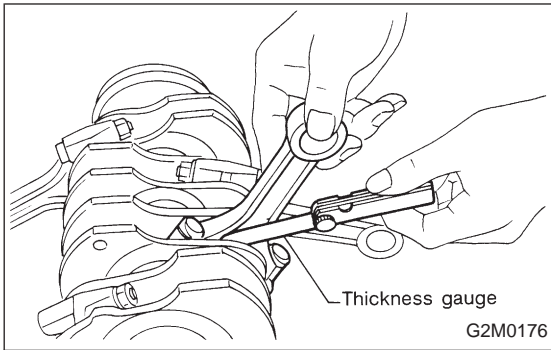

3) Install connecting rod fitted with bearing to crankshaft and measure the side clearance (thrust clearance). Replace connecting rod if the side clearance exceeds the specified limit.

**Connecting rod side clearance:**

**Standard**

**0.070 — 0.330 mm (0.0028 — 0.0130 in)**

**Limit**

**0.4 mm (0.016 in)**

4) Inspect connecting rod bearing for scar, peeling, seizure, melting, wear, etc.

5) Measure the oil clearance on individual connecting rod bearings by means of plastigauge. If any oil clearance is not within specification, replace the defective bearing with a new one of standard size or undersize as necessary. (See the table below.)

**Connecting rod oil clearance:**

**Standard**

**0.015 — 0.045 mm (0.0006 — 0.0018 in)**

**Limit**

**0.05 mm (0.0020 in)**

Unit: mm (in)

Bearing	Bearing size (Thickness at center)	Outer diameter of crank pin
Standard	1.492 — 1.501 (0.0587 — 0.0591)	51.984 — 52.000 (2.0466 — 2.0472)
0.03 (0.0012) undersize	1.510 — 1.513 (0.0594 — 0.0596)	51.954 — 51.970 (2.0454 — 2.0461)
0.05 (0.0020) undersize	1.520 — 1.523 (0.0598 — 0.0600)	51.934 — 51.950 (2.0446 — 2.0453)
0.25 (0.0098) undersize	1.620 — 1.623 (0.0638 — 0.0639)	51.734 — 51.750 (2.0368 — 2.0374)

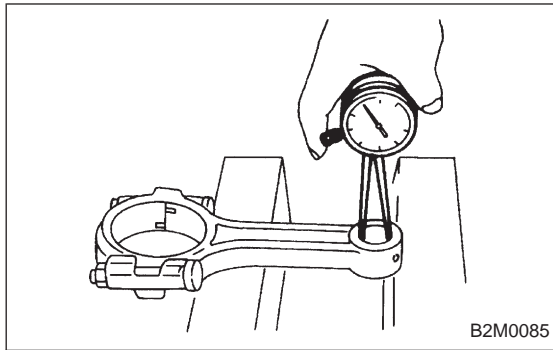

6) Inspect bushing at connecting rod small end, and replace if worn or damaged. Also measure the piston pin clearance at the connecting rod small end.

**Clearance between piston pin and bushing:**

**Standard**

**0 — 0.022 mm (0 — 0.0009 in)**

**Limit**

**0.030 mm (0.0012 in)**

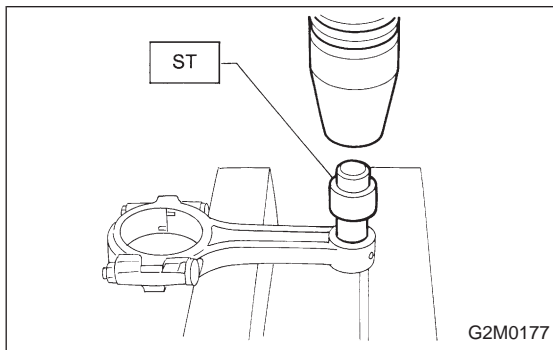
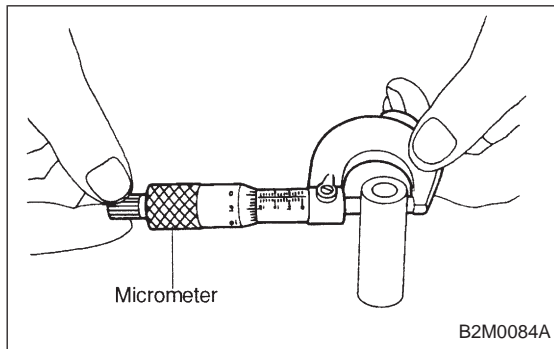

7) Replacement procedure is as follows.

(1) Remove bushing from connecting rod with ST and press.

(2) Press bushing with ST after applying oil on the periphery of bushing.

ST 499037100 CONNECTING ROD BUSHING  
REMOVER AND INSTALLER

(3) Make two 3 mm (0.12 in) holes in bushing. Ream the inside of bushing.

(4) After completion of reaming, clean bushing to remove chips.

## 6. CRANKSHAFT AND CRANKSHAFT BEARING

1) Clean crankshaft completely and check for cracks by means of red lead check etc., and replace if defective.

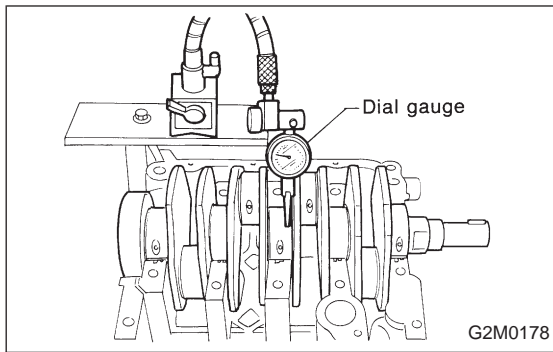

2) Measure the crankshaft bend, and correct or replace if it exceeds the limit.

**CAUTION:**

**If a suitable V-block is not available, install #1 and #5 crankshaft bearing on cylinder block, position crankshaft on these bearings and measure crankshaft bend using a dial gauge.**

**Crankshaft bend limit:**  
**0.035 mm (0.0014 in)**

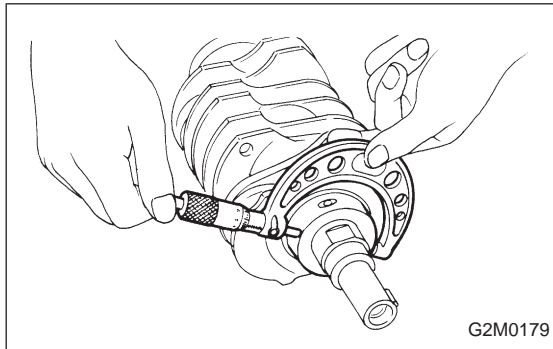

3) Inspect the crank journal and crank pin for wear. If not to specifications, replace bearing with an undersize one, and replace or recondition crankshaft as necessary. When grinding crank journal or crank pin, finish them to the specified dimensions according to the undersize bearing to be used.

**Crank pin and crank journal:**  
**Out-of-roundness**  
**0.030 mm (0.0012 in) or less**  
**Taper limit**  
**0.07 mm (0.0028 in)**  
**Grinding limit**  
**0.25 mm (0.0098 in)**

Unit: mm (in)

		Crank journal diameter		Crank pin diameter
		#1, #5	#2, #3, #4	
Standard	Journal O.D.	59.992 — 60.008 (2.3619 — 2.3625)	59.992 — 60.008 (2.3619 — 2.3625)	51.984 — 52.000 (2.0466 — 2.0472)
	Bearing size (Thickness at center)	1.998 — 2.011 (0.0787 — 0.0792)	2.000 — 2.013 (0.0787 — 0.0793)	1.492 — 1.501 (0.0587 — 0.0591)
0.03 (0.0012) undersize	Journal O.D.	59.962 — 59.978 (2.3607 — 2.3613)	59.954 — 59.970 (2.3604 — 2.3610)	51.954 — 51.970 (2.0454 — 2.0461)
	Bearing size (Thickness at center)	2.017 — 2.020 (0.0794 — 0.0795)	2.019 — 2.022 (0.0795 — 0.0796)	1.510 — 1.513 (0.0594 — 0.0596)
0.05 (0.0020) undersize	Journal O.D.	59.934 — 59.950 (2.3596 — 2.3602)	59.934 — 59.950 (2.3596 — 2.3602)	51.934 — 51.950 (2.0446 — 2.0453)
	Bearing size (Thickness at center)	2.027 — 2.030 (0.0798 — 0.0799)	2.029 — 2.032 (0.0799 — 0.0800)	1.520 — 1.523 (0.0598 — 0.0600)
0.25 (0.0098) undersize	Journal O.D.	59.742 — 59.758 (2.3520 — 2.3527)	59.734 — 59.750 (2.3517 — 2.3524)	51.734 — 51.750 (2.0368 — 2.0374)
	Bearing size (Thickness at center)	2.127 — 2.130 (0.0837 — 0.0839)	2.129 — 2.132 (0.0838 — 0.0839)	1.620 — 1.623 (0.0638 — 0.0639)

O.D. ... Outer Diameter

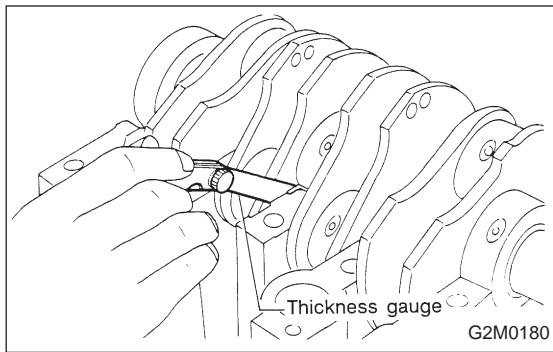

4) Measure the thrust clearance of crankshaft at center bearing. If the clearance exceeds the limit, replace bearing.

**Crankshaft thrust clearance:**

**Standard**

**0.030 — 0.115 mm (0.0012 — 0.0045 in)**

**Limit**

**0.25 mm (0.0098 in)**

5) Inspect individual crankshaft bearings for signs of flaking, seizure, melting, and wear.

6) Measure the oil clearance on each crankshaft bearing by means of plastigauge. If the measurement is not within the specification, replace defective bearing with an under-size one, and replace or recondition crankshaft as necessary.

Unit: mm (in)

Crankshaft oil clearance		
Standard	#1, #5	0.003 — 0.030 (0.0001 — 0.0012)
	#2, #3, #4	0.010 — 0.033 (0.0004 — 0.0013)
Limit	#1, #3, #5	0.040 (0.0016)
	#2, #4	0.035 (0.0014)

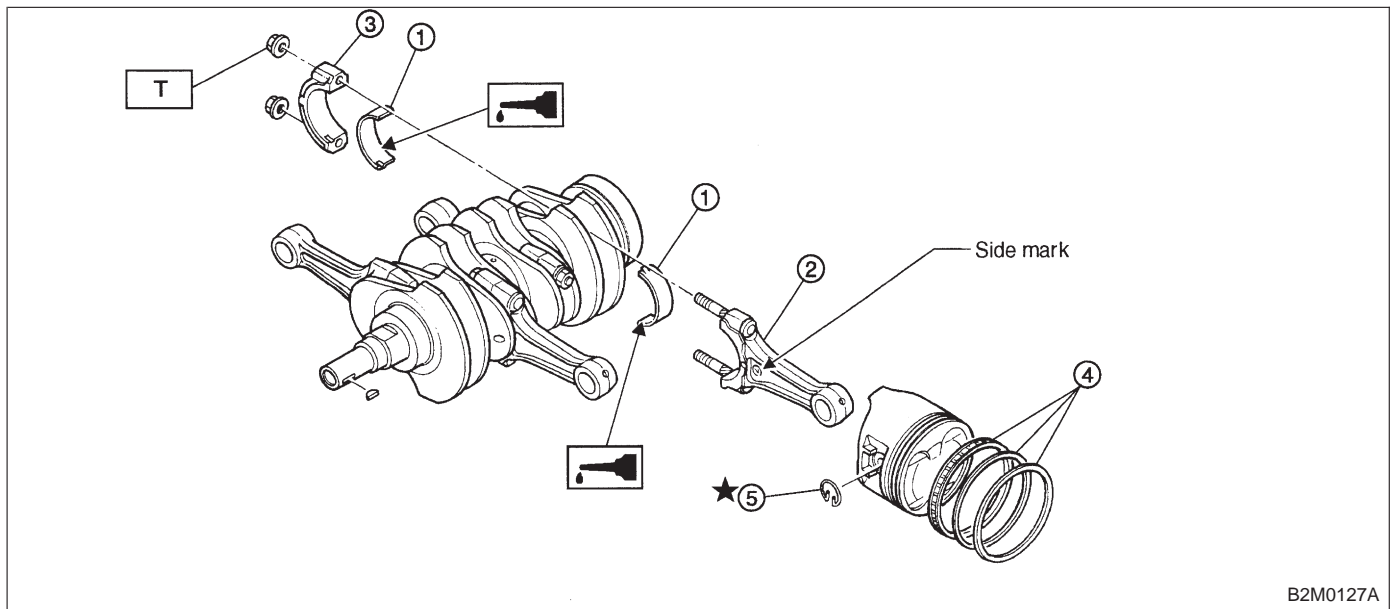
**D: ASSEMBLY****1. CRANKSHAFT AND PISTON**

**Tightening torque: N·m (kg·m, ft·lb)**  
**T: 44±2 (4.5±0.2, 32.5±1.4)**

1) Install connecting rod bearings on connecting rods and connecting rod caps.

**CAUTION:**

**Apply oil to the surfaces of the connecting rod bearings.**

2) Install connecting rod on crankshaft.

**CAUTION:**

**Position each connecting rod with the side marked facing forward.**

3) Install connecting rod cap with connecting rod nut.

Ensure the arrow on connecting rod cap faces the front during installation.

**CAUTION:**

- Each connecting rod has its own mating cap. Make sure that they are assembled correctly by checking their matching number.

- When tightening the connecting rod nuts, apply oil on the threads.



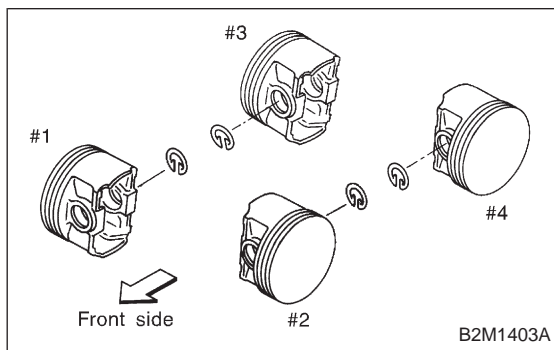
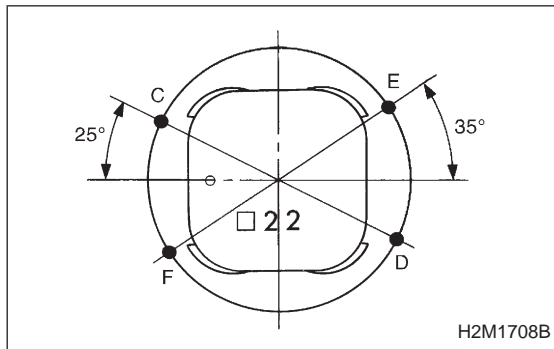
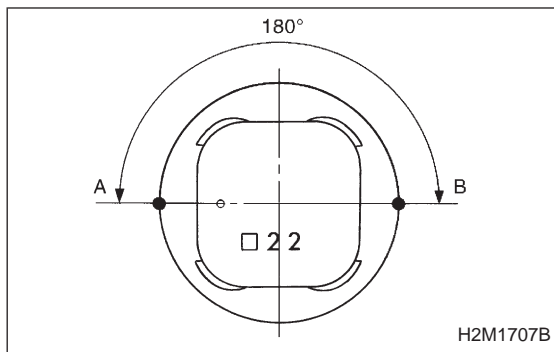

#### 4) Installation of piston rings and oil ring

(1) Install oil ring spacer, upper rail and lower rail in this order by hand. Then install second ring and top ring with a piston ring expander.

(2) Position the top ring gap at A or B in the Figure.

(3) Position the second ring gap at 180° on the reverse side for the top ring gap.

(4) Position the upper rail gap at C or D in the Figure.

(5) Position the expander gap at 180° of the reverse side for the upper rail gap.

(6) Position the lower rail gap at E or F in the Figure.

#### CAUTION:

- Ensure ring gaps do not face the same direction.
- Ensure ring gaps are not within the piston skirt area.

#### 5) Install circlip.

Install circlips in piston holes located opposite service holes in cylinder block, when positioning all pistons in the corresponding cylinders.

#### CAUTION:

**Use new circlips.**

#### NOTE:

Piston front mark "○" facer toward front of engine.

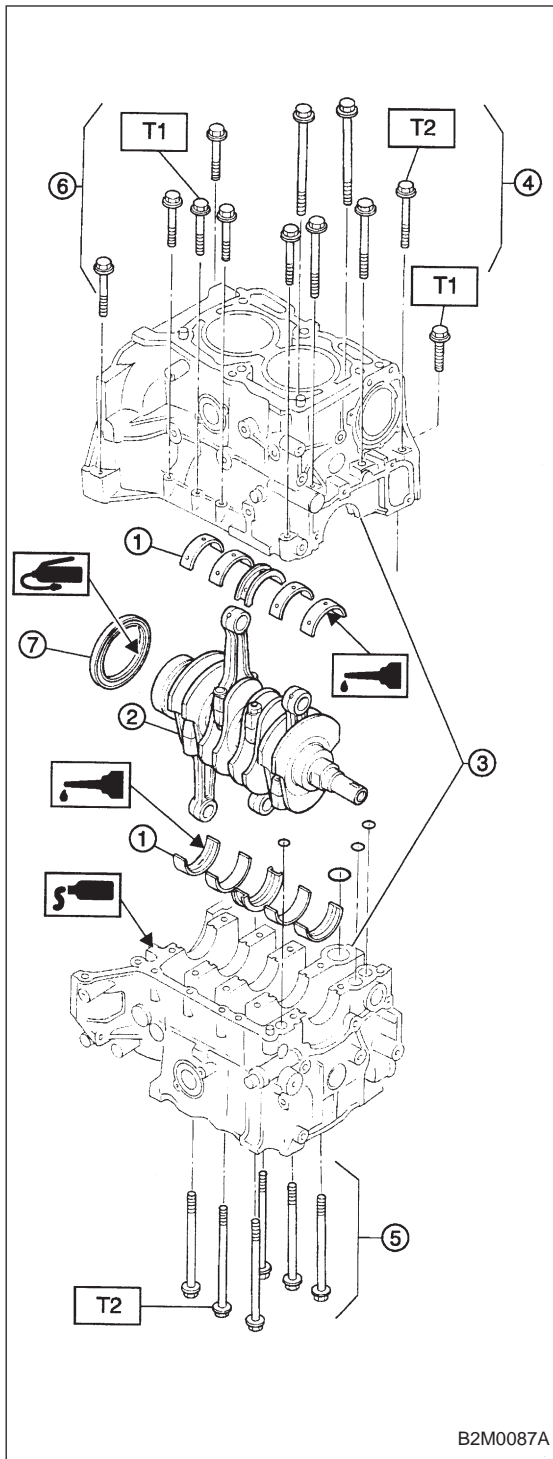

**2. CYLINDER BLOCK**

1) Install ST to cylinder block, then install crankshaft bearings.

ST 499817000 ENGINE STAND

**CAUTION:**

Remove oil the mating surface of bearing and cylinder block before installation. Also apply a coat of engine oil to crankshaft pins.

2) Position crankshaft on the #2 and #4 cylinder block.

**Tightening torque:**

**T1:  $25 \pm 2$  N·m (2.5 ± 0.2 kg-m, 18.1 ± 1.4 ft-lb)**

**T2:  $47 \pm 3$  N·m (4.8 ± 0.3 kg-m, 34.7 ± 2.2 ft-lb)**

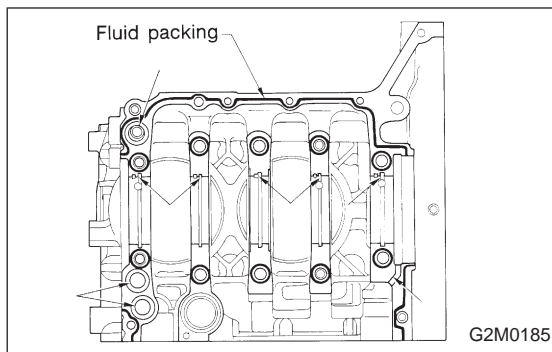

3) Apply fluid packing to the mating surface of #1 and #3 cylinder block, and position it on #2 and #4 cylinder block.

**Fluid packing:**

**THREE BOND 1215 or equivalent**

**CAUTION:**

**Do not allow fluid packing to jut into O-ring grooves, oil passages, bearing grooves, etc.**

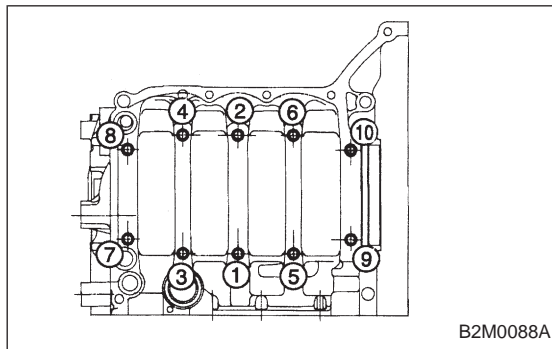

4) Temporarily tighten 10 mm cylinder block connecting bolts in numerical order shown in Figure.

5) Tighten 10 mm cylinder block connecting bolts in numerical order.

**Tightening torque:**

**$47 \pm 3 \text{ N}\cdot\text{m}$  ( $4.8 \pm 0.3 \text{ kg}\cdot\text{m}$ ,  $34.7 \pm 2.2 \text{ ft}\cdot\text{lb}$ )**

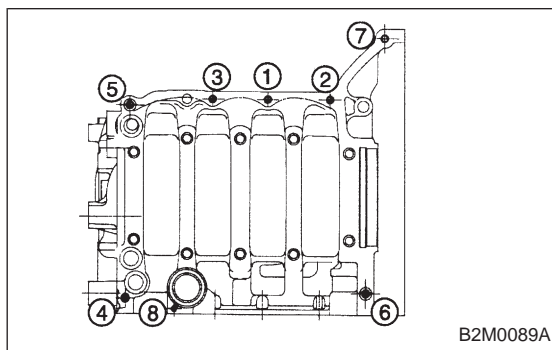

6) Tighten 8 mm and 6 mm cylinder block connecting bolts in numerical order shown in Figure.

**Tightening torque:**

① — ⑦:  **$25 \pm 2 \text{ N}\cdot\text{m}$**

**( $2.5 \pm 0.2 \text{ kg}\cdot\text{m}$ ,  $18.1 \pm 1.4 \text{ ft}\cdot\text{lb}$ )**

⑧:  **$6.4 \text{ N}\cdot\text{m}$  ( $0.65 \text{ kg}\cdot\text{m}$ ,  $4.7 \text{ ft}\cdot\text{lb}$ )**

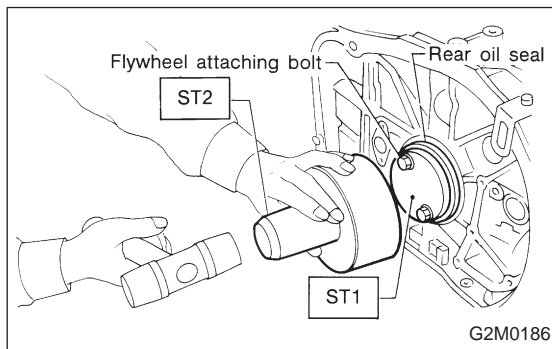

7) Install rear oil seal by using ST1 and ST2.

ST1 499597100 OIL SEAL GUIDE

ST2 499587200 OIL SEAL INSTALLER

3. PISTON AND PISTON PIN (#1 AND #2)

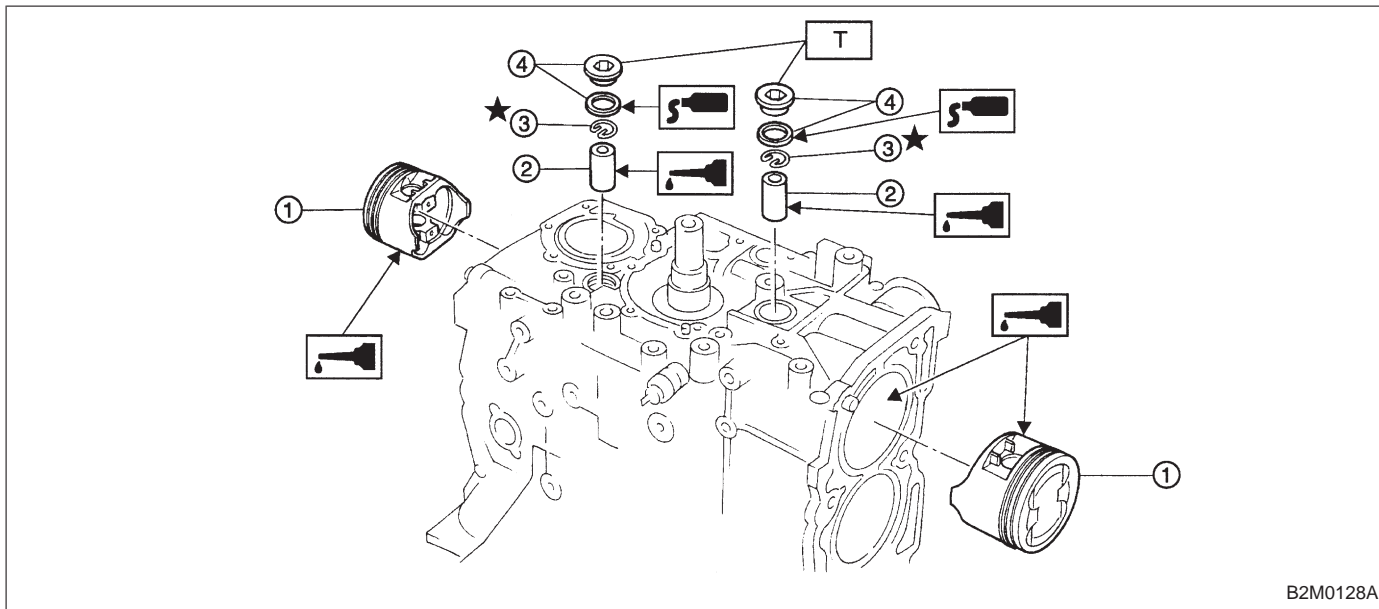

**Tightening torque: N·m (kg·m, ft·lb)**  
**T: 69±7 (7.0±0.7, 50.6±5.1)**

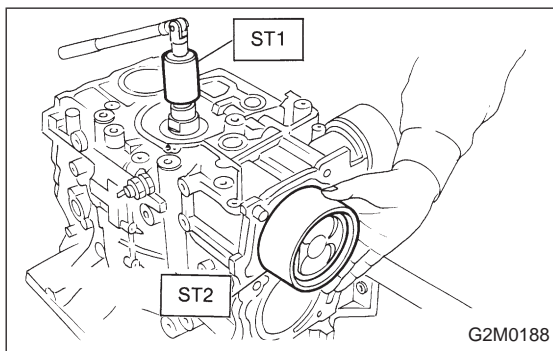

- 1) Installing piston
  - (1) Turn cylinder block so that #1 and #2 cylinders face upward.
  - (2) Using ST1, turn crankshaft so that #1 and #2 connecting rods are set at bottom dead center.

ST1 499987500 CRANKSHAFT SOCKET

- (3) Apply a coat of engine oil to pistons and cylinders and insert pistons in their cylinders by using ST2.

ST2 498747100 PISTON GUIDE

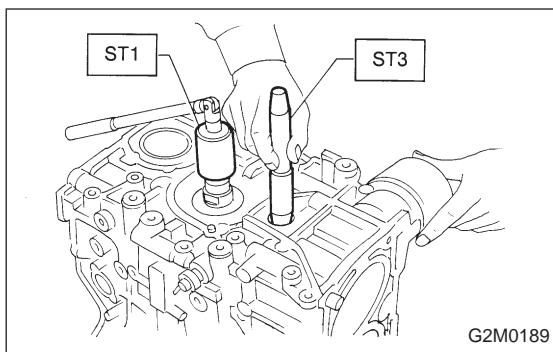

- 2) Installing piston pin

- (1) Insert ST3 into service hole to align piston pin hole with connecting rod small end.

**CAUTION:**

**Apply a coat of engine oil to ST3 before insertion.**

ST3 499017100 PISTON PIN GUIDE

(2) Apply a coat of engine oil to piston pin and insert piston pin into piston and connecting rod through service hole.

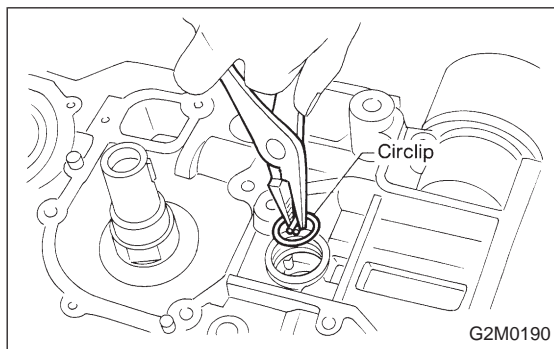

(3) Install circlip.

**CAUTION:**  
Use new circlips.

(4) Install service hole plug and gasket.

**CAUTION:**  
Use a new gasket and apply a coat of fluid packing to it before installation.

**Fluid packing:**  
*THREE BOND 1215 or equivalent*

4. PISTON AND PISTON PIN (#3 AND #4)

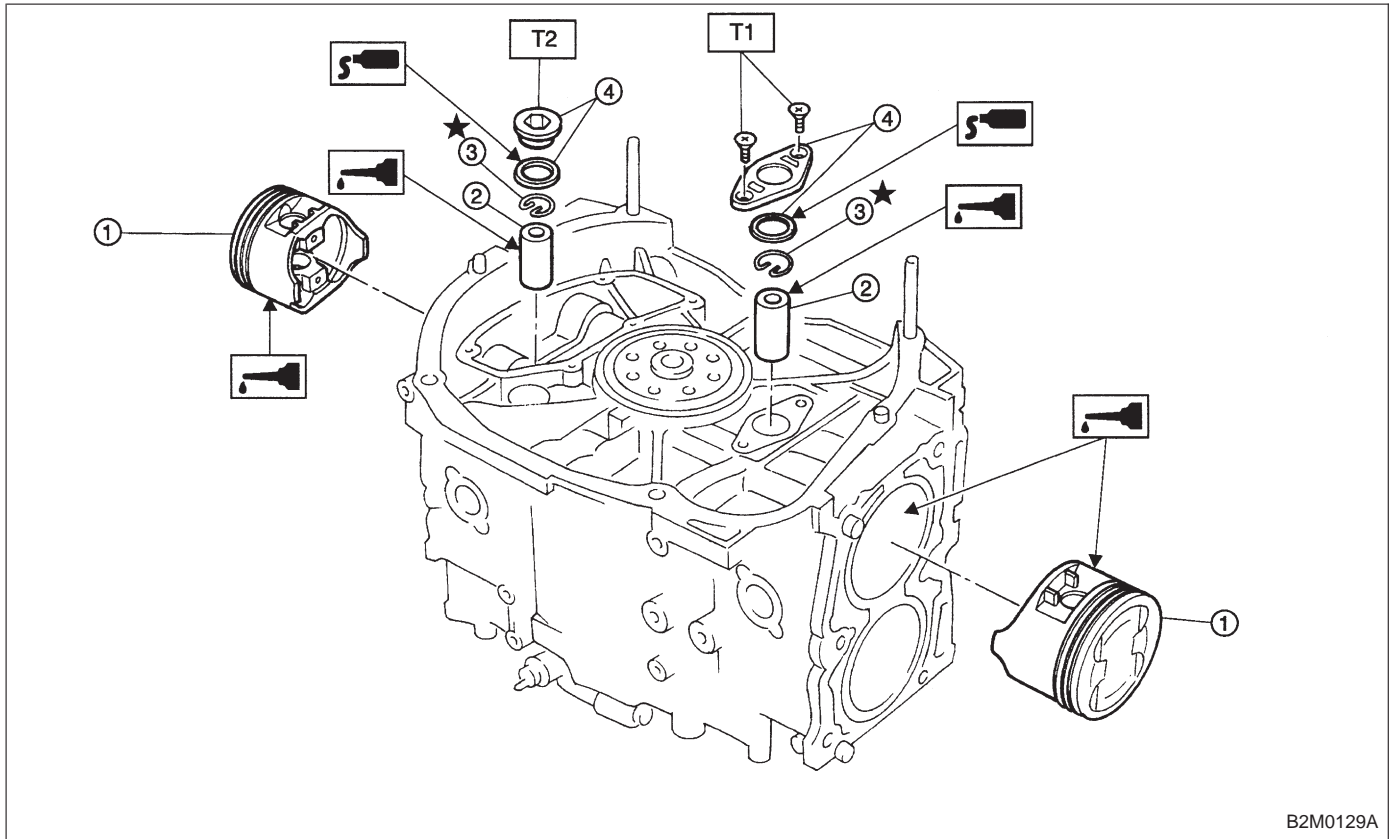

B2M0129A

**Tightening torque: N·m (kg·m, ft·lb)**  
**T1: 6.4 (0.65, 4.7)**  
**T2: 69±7 (7.0±0.7, 50.6±5.1)**

Turn cylinder block so that #3 and #4 cylinders face upward. Using the same procedures as used for #1 and #2 cylinders, install pistons and piston pins.

## E: INSTALLATION

## 1. OIL PUMP AND ENGINE COOLANT PUMP

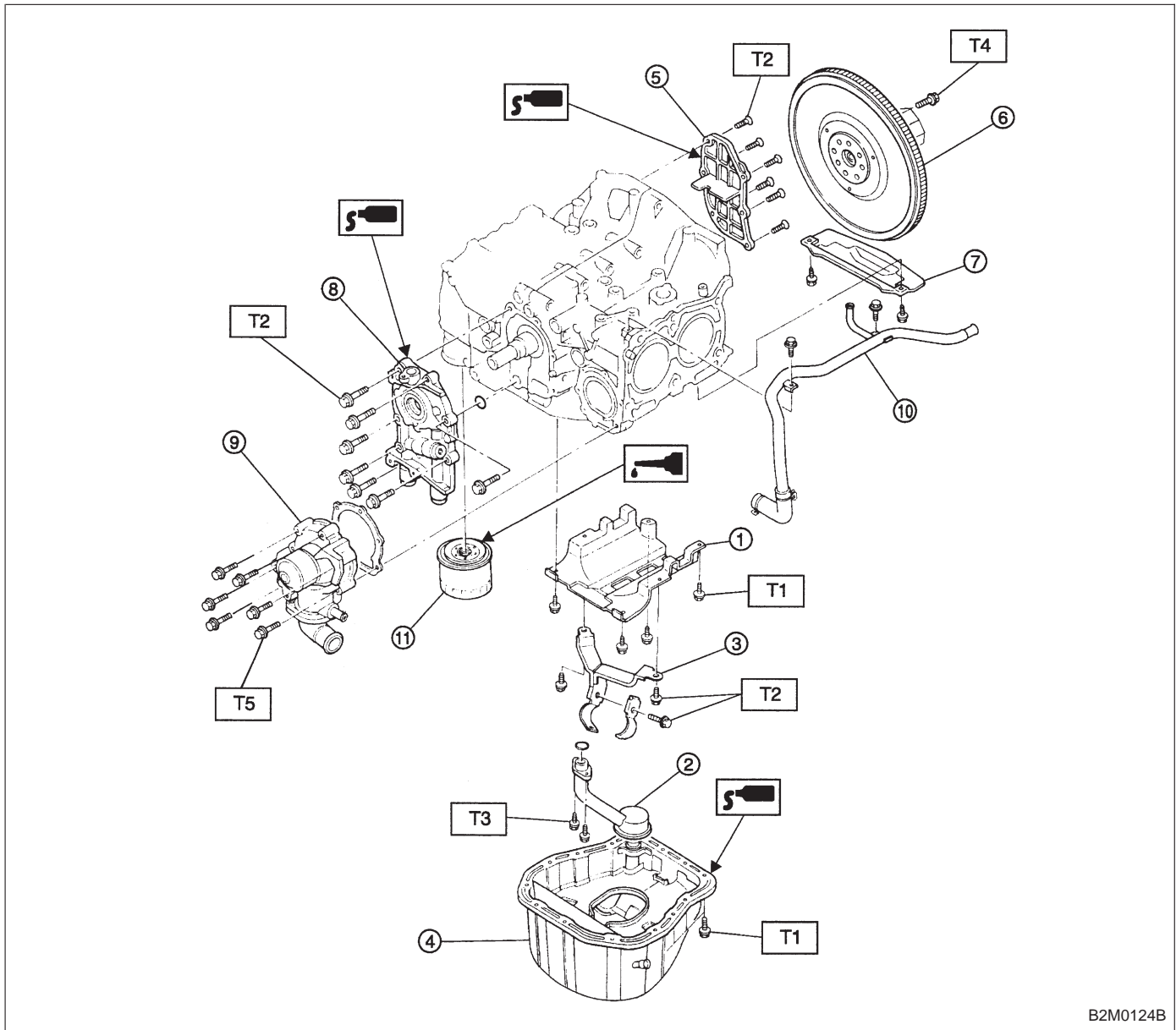

B2M0124B

**Tightening torque: N·m (kg·m, ft·lb)**

T1: 5 (0.5, 3.6)

T2: 6.4 (0.65, 4.7)

T3: 10 (1.0, 7)

T4:  $72 \pm 3$  ( $7.3 \pm 0.3$ ,  $52.8 \pm 2.2$ )T5: First  $12 \pm 2$  ( $1.2 \pm 0.2$ ,  $8.7 \pm 1.4$ )Second  $12 \pm 2$  ( $1.2 \pm 0.2$ ,  $8.7 \pm 1.4$ )

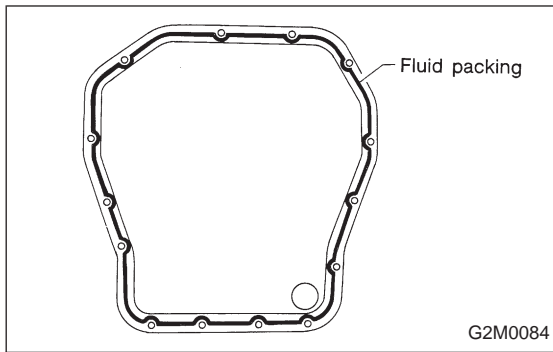

- 1) Install baffle plate.
- 2) Install oil strainer and O-ring
- 3) Install oil strainer stay.
- 4) Apply fluid packing to matching surfaces and install oil pan.

**Fluid packing:**  
**THREE BOND 1207C or equivalent**

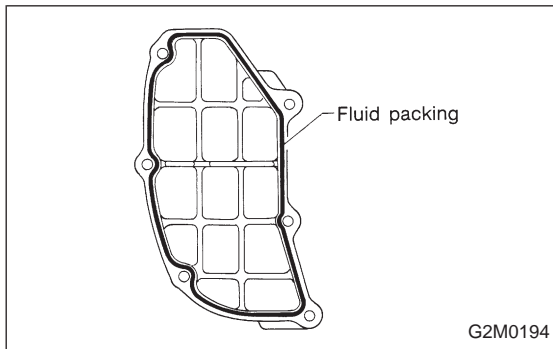

- 5) Apply fluid packing to matching surfaces and install oil separator cover.

**Fluid packing:**  
**THREE BOND 1215 or equivalent**

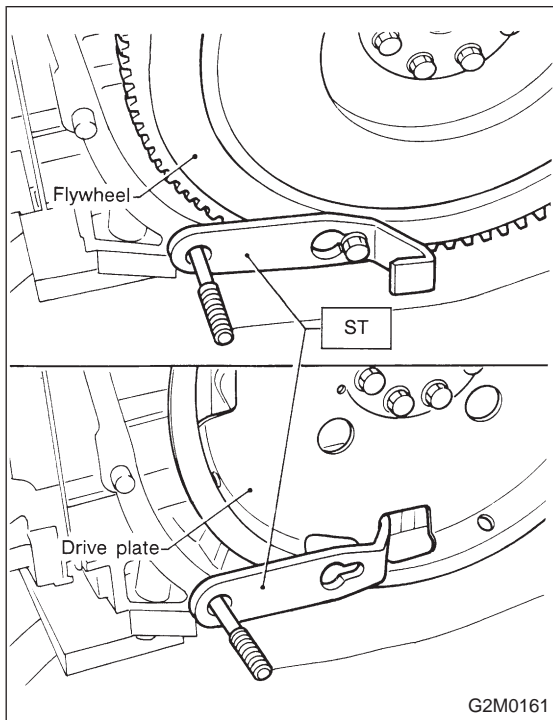

- 6) Install flywheel or drive plate.  
 To lock crankshaft, use ST.  
 ST 498497100 CRANKSHAFT STOPPER
- 7) Install housing cover.

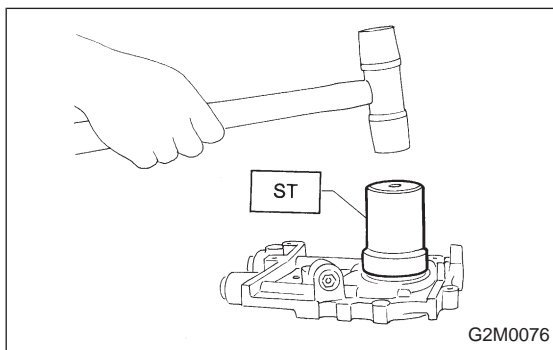

- 8) Installation of oil pump
  - (1) Discard front oil seal after removal. Replace with a new one by using ST.
 ST 499587100 OIL SEAL INSTALLER



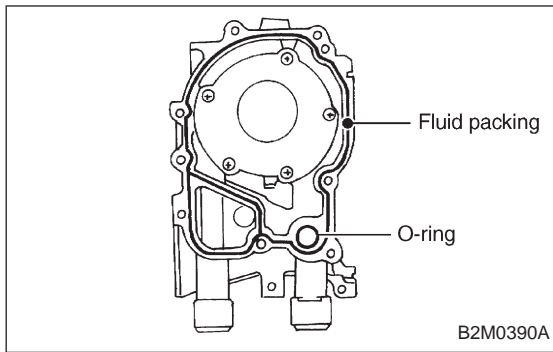

(2) Apply fluid packing to matching surface of oil pump.

**Fluid packing:**

**THREE BOND 1215 or equivalent**

(3) Install oil pump on cylinder block. Be careful not to damage oil seal during installation.

**CAUTION:**

- Do not forget to install O-ring and seal when installing oil pump.
- Align flat surface of oil pump's inner rotor with crankshaft before installation.

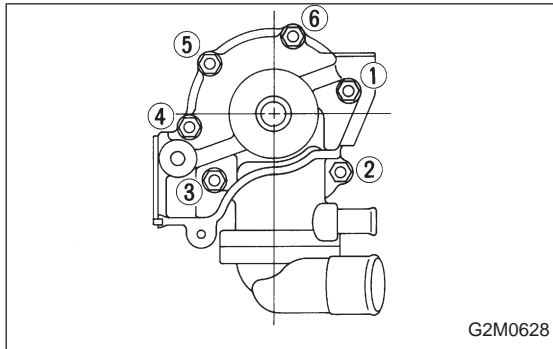

9) Install engine coolant pump and gasket.

**CAUTION:**

- Be sure to use a new gasket.
- When installing engine coolant pump, tighten bolts in two stages in numerical sequence as shown in Figure.

10) Install engine coolant pipe.

11) Install oil filter.

**2. RELATED PARTS**

1) Install cylinder head and intake manifold.

<Ref. to 2-3 [W6E0].>

2) Install timing belt, camshaft sprocket and related parts.

<Ref. to 2-3 [W3C0].>