

## 10. Camshaft Position Sensor

### A: REMOVAL AND INSTALLATION

1) Disconnect connector from camshaft position sensor.

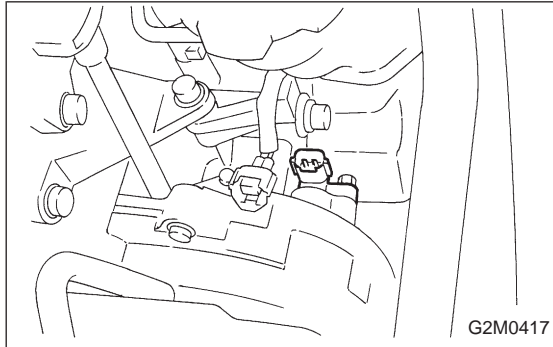

2) Remove camshaft position sensor from camshaft support LH.

3) Installation is in the reverse order of removal.

#### **Tightening torque:**

**$6.4 \pm 0.5 \text{ N}\cdot\text{m}$  ( $0.65 \pm 0.05 \text{ kg}\cdot\text{m}$ ,  $4.7 \pm 0.4 \text{ ft}\cdot\text{lb}$ )**

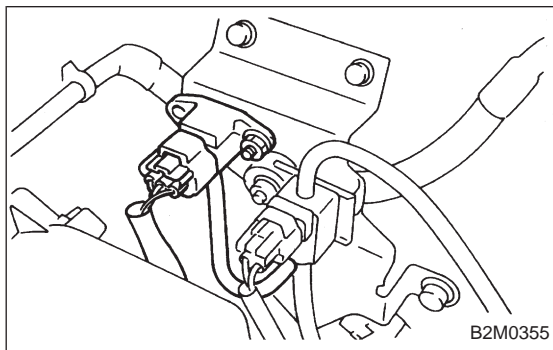

## 11. Pressure Sensor (AT model)

### A: REMOVAL AND INSTALLATION

1) Disconnect connector from pressure sensor.

2) Disconnect hose from pressure sensor.

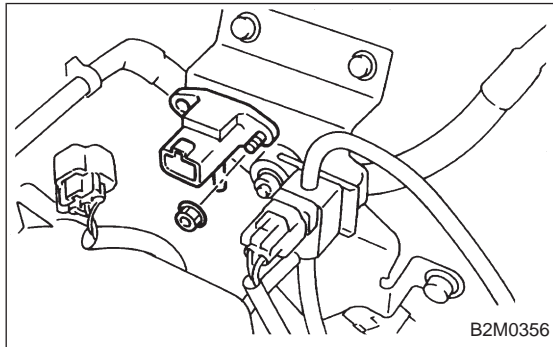

3) Remove pressure sensor from bracket.

4) Installation is in the reverse order of removal.

#### **Tightening torque:**

**$6.4 \pm 0.5 \text{ N}\cdot\text{m}$  ( $0.65 \pm 0.05 \text{ kg}\cdot\text{m}$ ,  $4.7 \pm 0.4 \text{ ft}\cdot\text{lb}$ )**