

- 4) Disconnect connector from fuel sub meter.
- 5) Disconnect jet pump hose.

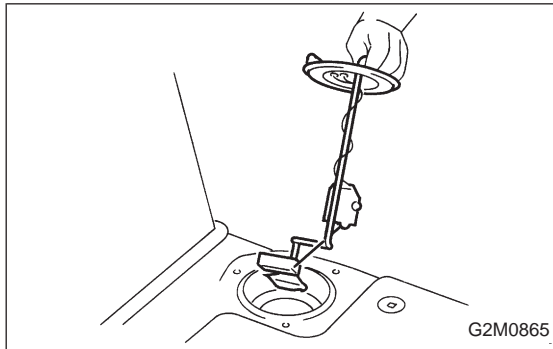

- 6) Remove fuel sub meter unit.

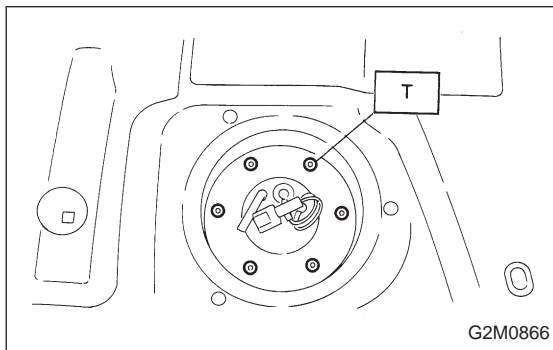

- 7) Installation is in the reverse order of removal procedure.

Tightening torque:

T: 3 — 6 N·m (0.3 — 0.6 kg·m, 2.2 — 4.3 ft·lb)

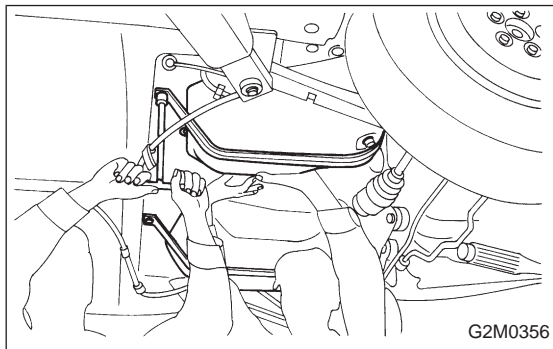

11. Fuel Cut Valve (AWD model only)

A: REMOVAL AND INSTALLATION

- 1) Remove fuel tank. <Ref. to 2-8 [W3A0].>

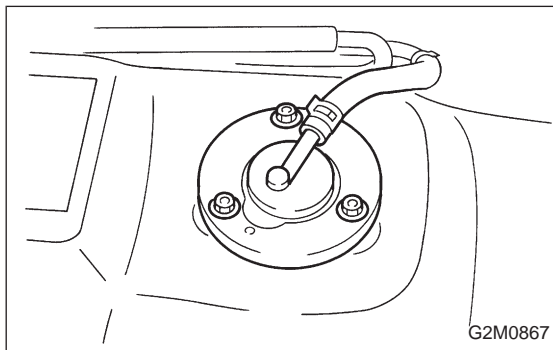

- 2) Disconnect evaporation hose from fuel cut valve.
- 3) Remove fuel cut valve.
- 4) Installation is in the reverse order of removal procedure.

Tightening torque:

4.4±1.5 N·m (0.45±0.15 kg·m, 3.3±1.1 ft·lb)