

## 14. Evaporator Module

### A: REMOVAL AND INSTALLATION

- 1) Disconnect battery negative terminal.
- 2) Discharge refrigerant using refrigerant recovery system. <Ref. to 4-7 [W601].>
- 3) Disconnect discharge pipe, suction pipe and grommets.

- 4) Remove glove box and pocket back panel. <Ref. to 5-4 [W1A0].>

- 5) Disconnect the harness connector from evaporator.
- 6) Disconnect drain hose.
- 7) Remove evaporator mounting bolt and nut.
- 8) Install the evaporator in the reverse order of removal.
- 9) Charge refrigerant. <Ref. to 4-7 [W708].>

### B: DISASSEMBLY AND ASSEMBLY

- 1) Remove resistor assembly ① and remove six screws from evaporator case.

- 2) Remove thermostat ① from upper case. (Thermistor ② is inserted into specified evaporator fin position.) When installing thermostat, be sure to insert thermistor into specified fin position.

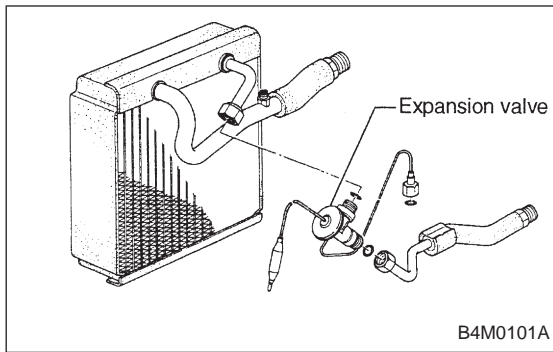

- 3) Disconnect the connection between the expansion valve and pipe from receiver drier.
- 4) Remove the expansion valve from pipes.
- 5) To install expansion valve, reverse removal procedures. Properly wrap capillary tube of expansion valve with seal.
- 6) Check to see if the evaporator fins are clogged. If they are, clean them with compressed air.

**CAUTION:**

**Water must never be used to clean the evaporator.**

7) Check parts that have been removed for cracks or scratches, and repair or replace them with new ones, if necessary.

8) Reassemble the evaporator in the reverse order of disassembly.

**NOTE:**

Confirm that the O-ring is inserted in the specified position.

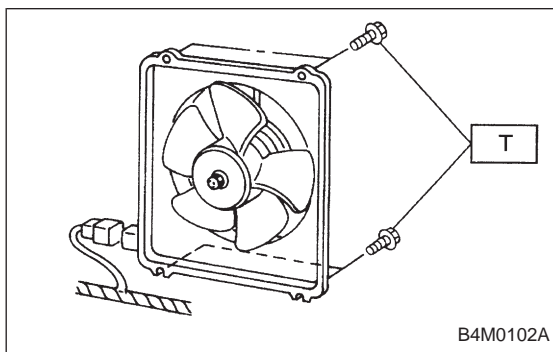

**15. Condenser Fan Assembly**

**A: REMOVAL AND INSTALLATION**

- 1) Disconnect battery negative terminal.
- 2) Disconnect harness connector from fan motor.
- 3) Remove condenser fan bolt from radiator.
- 4) Pull condenser fan assembly.
- 5) Install the condenser fan assembly in the reverse order of removal.

**Tightening torque:**

**T: 7.4±2.0 N·m (0.75±0.2 kg-m, 5.4±1.4 ft-lb)**