

6. ABS System

1. SENSOR AND CONTROL MODULE

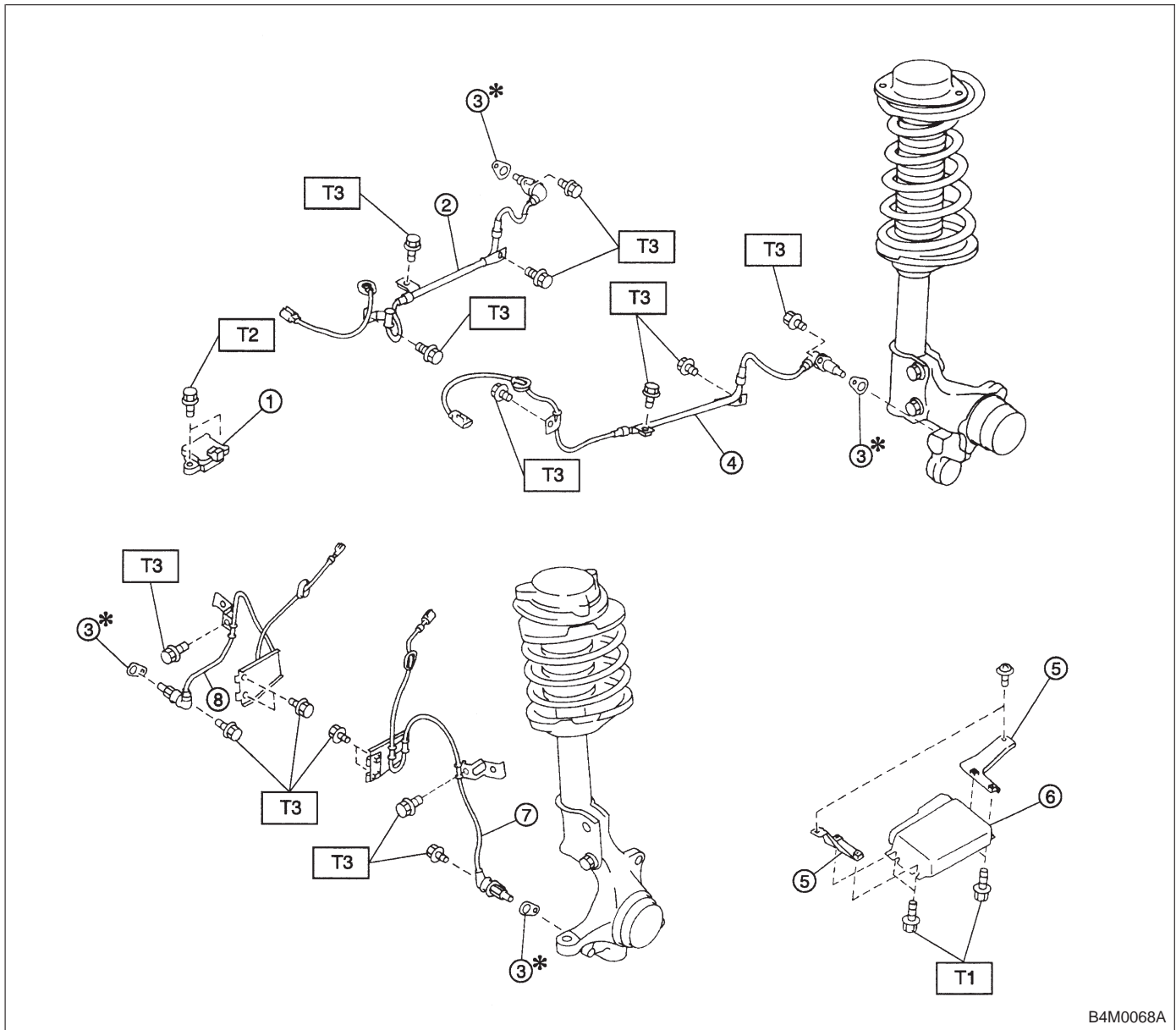

B4M0068A

- ① G sensor (AWD MT only)
- ② Rear ABS sensor RH
- ③ ABS spacer
- ④ Rear ABS sensor LH
- ⑤ Bracket
- ⑥ ABS control module
- ⑦ Front ABS sensor LH
- ⑧ Front ABS sensor RH

Tightening torque: N·m (kg·m, ft·lb)

T1: 5.9±1.5 (0.60±0.15, 4.3±1.1)

T2: 7.4±2.0 (0.75±0.2, 5.4±1.4)

T3: 32±10 (3.3±1.0, 24±7)

2. HYDRAULIC CONTROL UNIT

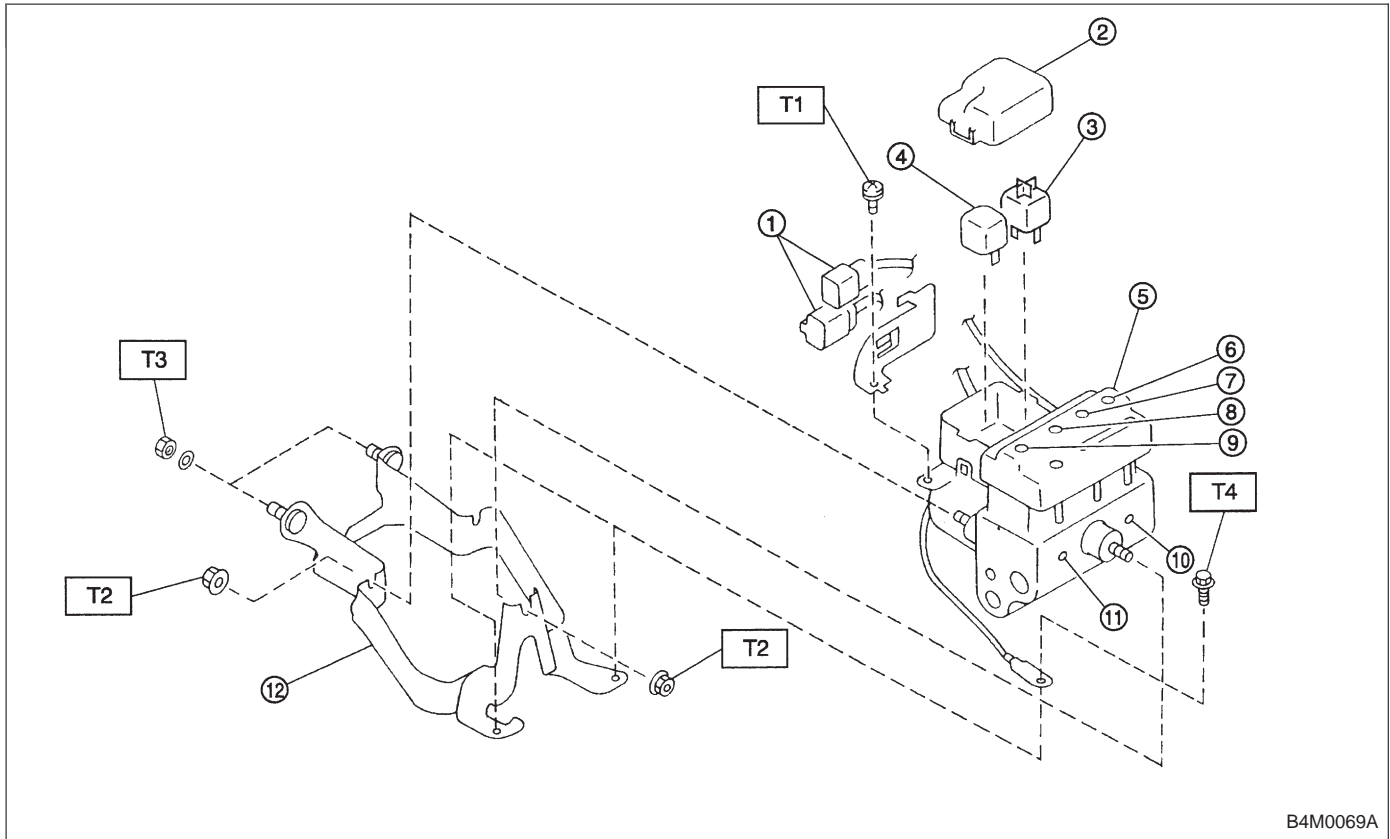

B4M0069A

- ① Connector
- ② Cap
- ③ Motor relay
- ④ Valve relay
- ⑤ Hydraulic control unit
- ⑥ Front-RH outlet
- ⑦ Rear-LH outlet
- ⑧ Rear-RH outlet

- ⑨ Front-LH outlet
- ⑩ Primary inlet
- ⑪ Secondary inlet
- ⑫ Bracket

Tightening torque: N·m (kg·m, ft·lb)
T1: 1.2±0.2
 (0.125±0.025, 0.9±0.2)
T2: 18±5 (1.8±0.5, 13.0±3.6)
T3: 29±7 (3.0±0.7, 21.7±5.1)
T4: 32±10 (3.3±1.0, 24±7)