

9. ABS/TCS System

1. SENSOR AND CONTROL MODULE

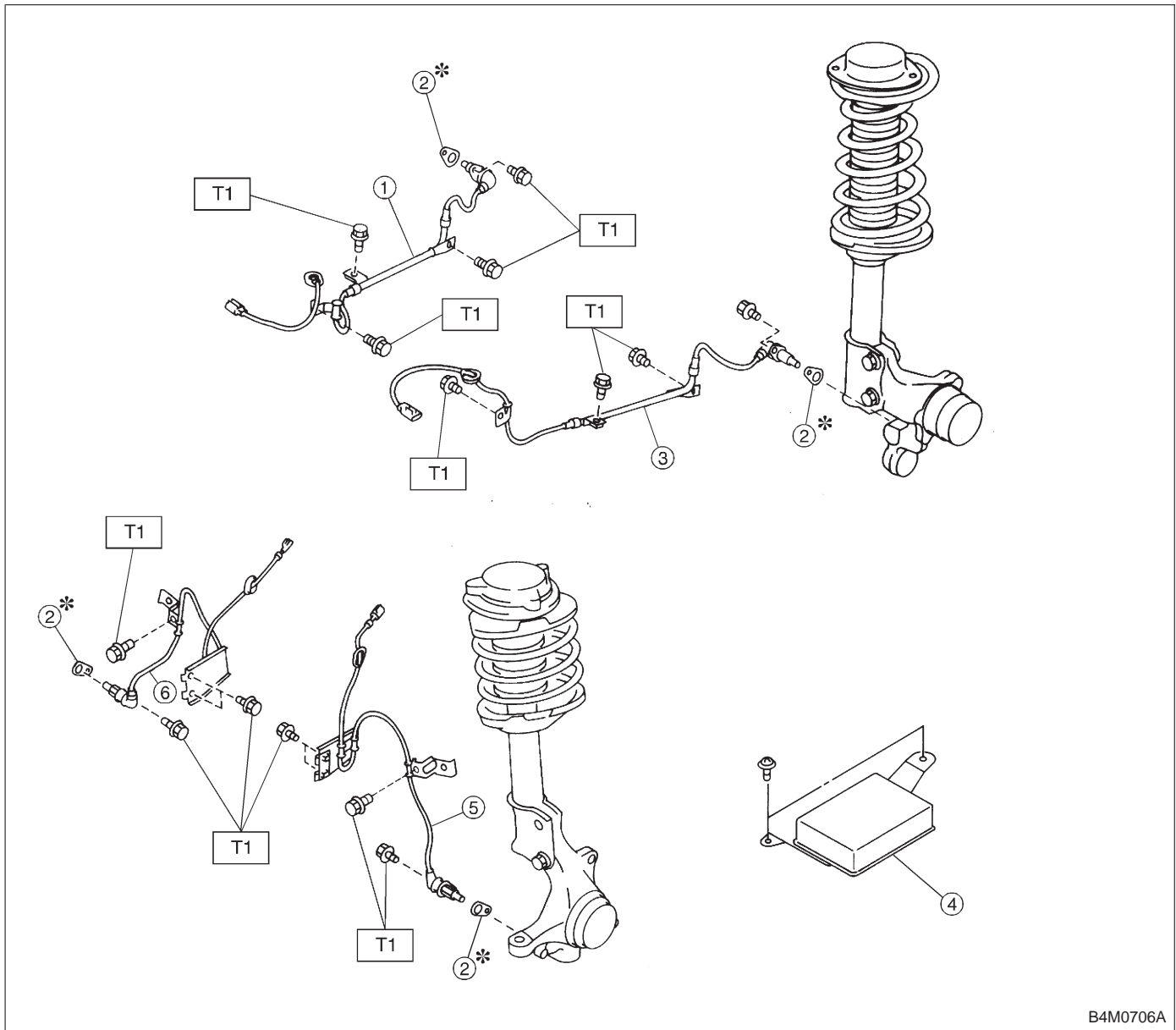

- ① Rear ABS sensor RH
- ② ABS spacer
- ③ Rear ABS sensor LH

- ④ ABS/TCS control module
- ⑤ Front ABS sensor LH
- ⑥ Front ABS sensor RH

**Tightening torque: N·m (kg·m, ft·lb)**  
**T1: 32±10 (3.3±1.0, 24±7)**

2. HYDRAULIC UNIT

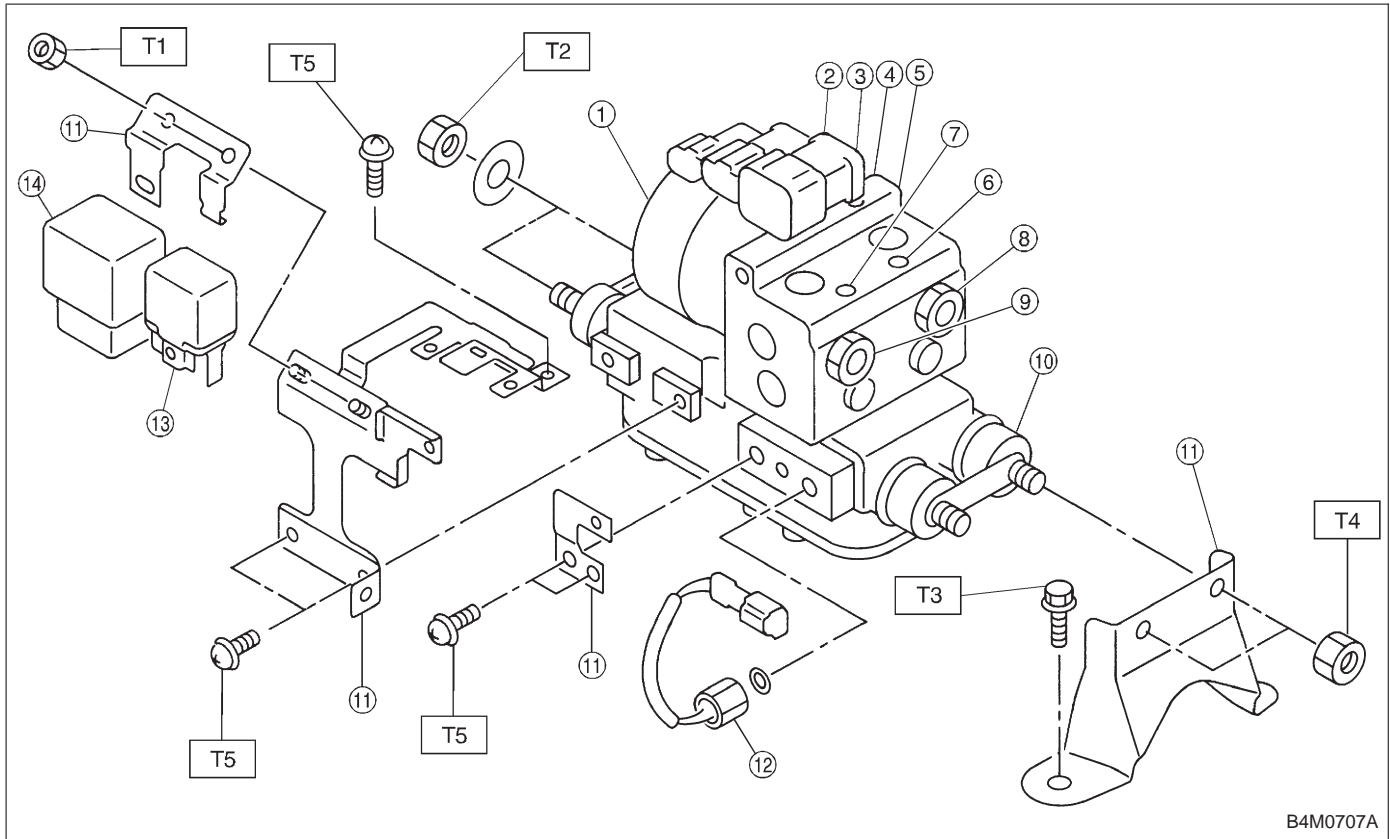

- ① ABS/TCS Hydraulic control unit
- ② Rear-RH outlet
- ③ Front-LH outlet
- ④ Front-RH outlet
- ⑤ Rear-LH outlet
- ⑥ Secondary inlet
- ⑦ Primary inlet

- ⑧ Secondary suction line
- ⑨ Primary suction line
- ⑩ Bumper
- ⑪ Bracket
- ⑫ Pressure switch
- ⑬ Valve relay
- ⑭ Motor relay

**Tightening torque: N·m (kg·m, ft·lb)**  
**T1: 7.4±2.0 (0.75±0.2, 5.4±1.4)**  
**T2: 29±7 (3.0±0.7, 21.7±5.1)**  
**T3: 32±10 (3.3±1.0, 24±7)**  
**T4: 38±10 (3.8±1.0, 27±7)**  
**T5: 3.1±1 (0.32±0.1, 2.3±0.7)**