

## 8. Pipe Assembly (Power Steering System) [RHD model]

### A: REMOVAL

1) Disconnect battery negative terminal.

2) Lift vehicle and remove jack-up plate.

3) Remove one pipe joint at the center of gearbox, and connect vinyl hose to pipe and joint. Discharge fluid by turning steering wheel fully clockwise and counterclockwise. Discharge fluid similarly from the other pipe.

#### CAUTION:

Improper removal and installation of parts often causes fluid leak trouble. To prevent this, clean the surrounding portions before disassembly and reassembly, and pay special attention to keep dirt and other foreign matter from mating surfaces.

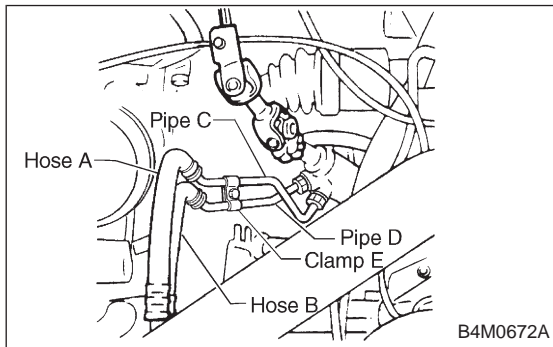

4) Remove clamp E from pipes C and D.

5) Remove flare nuts from control valve of gearbox assembly, and then disconnect pipe C·D.

**CAUTION:**

- When disconnecting pipe C·D, use two wrenches to prevent deformities.
- Be careful to keep pipe connections free from foreign matter.

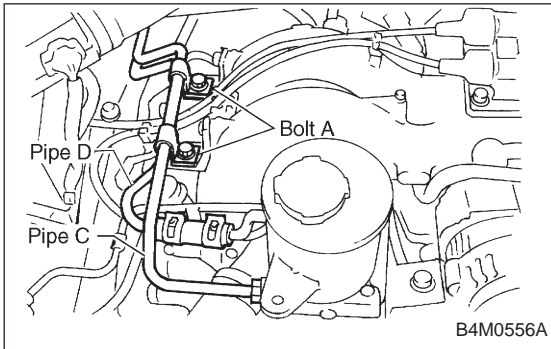

6) Remove bolt A.

Disconnect pipe C from oil pump. Disconnect pipe D from oil tank.

**CAUTION:**

- Do not allow fluid from the hose end to come into contact with pulley belt.
- To prevent foreign matter from entering the hose and pipe, cover the open ends of them with a clean cloth.

**B: CHECK**

Check all disassembled parts for wear, damage or other abnormalities. Repair or replace faulty parts as required.

Part name	Inspection	Remedy
Pipe	<ul style="list-style-type: none"> <li>● O-ring fitting surface for damage</li> <li>● Nut for damage</li> <li>● Pipe for damage</li> </ul>	Replace with new one.
Clamp Clamp E	<ul style="list-style-type: none"> <li>● Clamps for weak clamping force</li> </ul>	Replace with new one.
Hose	<ul style="list-style-type: none"> <li>● Flared surface for damage</li> <li>● Flare nut for damage</li> <li>● Outer surface for cracks</li> <li>● Outer surface for wear</li> <li>● Clip for damage</li> <li>● End coupling or adapter for degradation</li> </ul>	Replace with new one.

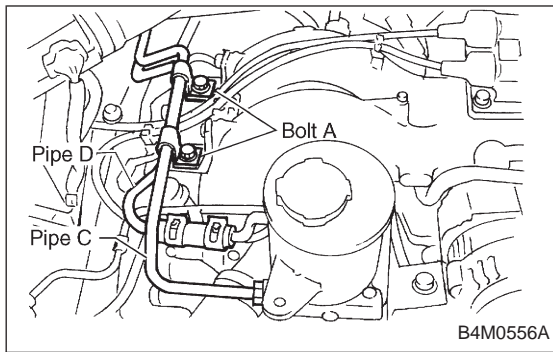

**C: ASSEMBLY**

1) Interconnect pipes C and D.

**Tightening torque:**

**Joint nut**

**$15\pm 5 \text{ N}\cdot\text{m}$  ( $1.5\pm 0.5 \text{ kg}\cdot\text{m}$ ,  $10.8\pm 3.6 \text{ ft}\cdot\text{lb}$ )**

**CAUTION:**

**Visually check that hose between tank and pipe D is free from bending or twisting.**

2) Tighten bolt A.

**Tightening torque:**

**$13\pm 3 \text{ N}\cdot\text{m}$  ( $1.3\pm 0.3 \text{ kg}\cdot\text{m}$ ,  $9.4\pm 2.2 \text{ ft}\cdot\text{lb}$ )**

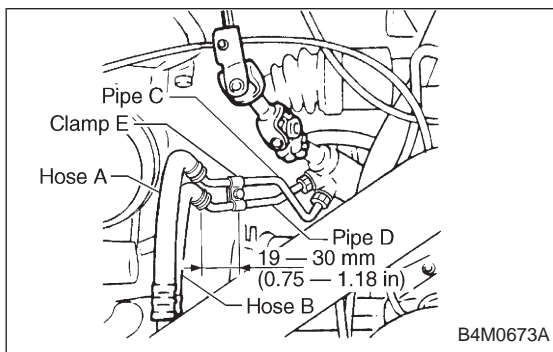

3) Temporarily connect pipes C and D to control valve of gearbox.

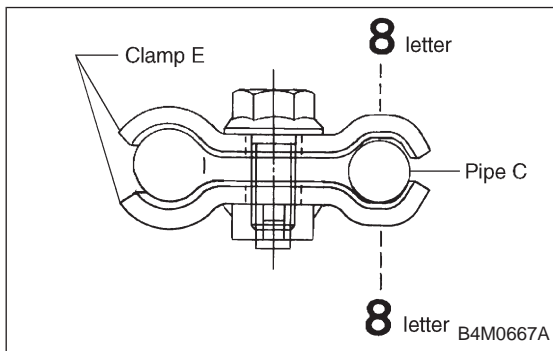

4) Temporarily install clamp E on pipes C and D.

**CAUTION:**

**Ensure that the letter “8” side of clamp E is on the pipe C side as shown in the figure.**

5) Tighten clamp E firmly.

**Tightening torque:**

**$7.4\pm 2.0 \text{ N}\cdot\text{m}$  ( $0.75\pm 0.20 \text{ kg}\cdot\text{m}$ ,  $5.4\pm 1.4 \text{ ft}\cdot\text{lb}$ )**

6) Tighten joint nut.

**Tightening torque:**

**$15\pm 5 \text{ N}\cdot\text{m}$  ( $1.5\pm 0.5 \text{ kg}\cdot\text{m}$ ,  $10.8\pm 3.6 \text{ ft}\cdot\text{lb}$ )**

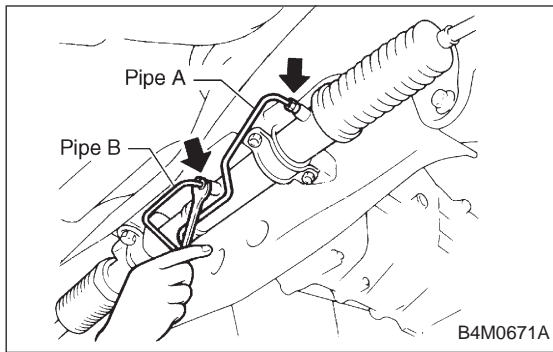

7) Connect pipes A and B to four pipe joints of gearbox. Connect upper pipe A first, and lower pipe B second.

**Tightening torque:**

**$13\pm 3$  N·m ( $1.3\pm 0.3$  kg·m,  $9.4\pm 2.2$  ft·lb)**

8) Install jack-up plate.

9) Connect battery negative terminal.

10) Feed the specified fluid and discharge air.

**NOTE:**

Never start the engine before feeding the fluid; otherwise vane pump might be seized up.

