

## 5. Reduction Drive Gear Assembly

### A: DISASSEMBLY

1) Take out the seal rings.

**CAUTION:**

**Be careful not to damage the seal rings.**

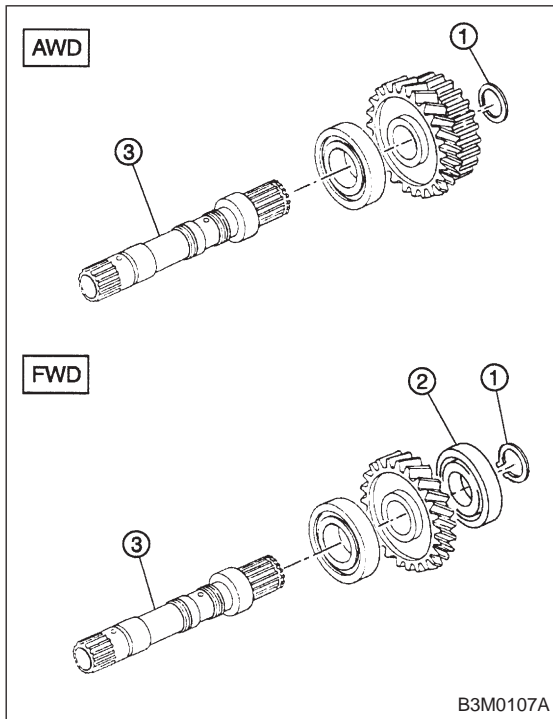

2) Take out the snap ring (outer ①).

**CAUTION:**

**Be careful not to damage the splines.**

3) Using a press, remove the ball bearing ② from shaft ③. (FWD only)

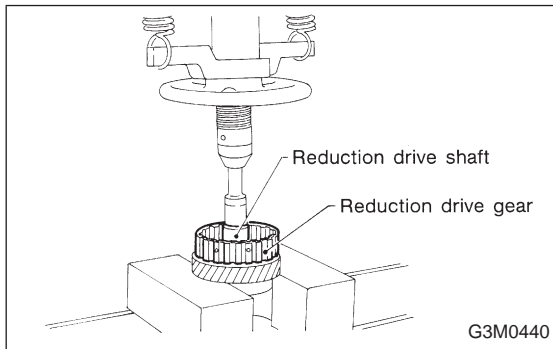

4) Using a press, remove the reduction drive gear.

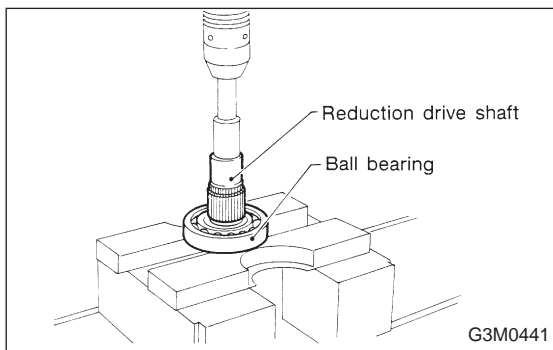

5) Using a press, remove the ball bearing.

**B: INSPECTION**

Make sure that each component is free of harmful gouges, cuts, or dust.

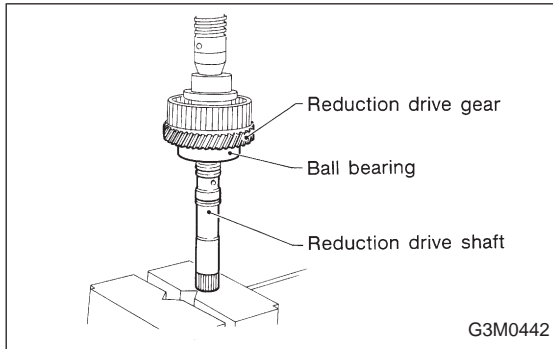
**C: ASSEMBLY**

1) Press-fit the ball bearing and reduction drive gear to the shaft.

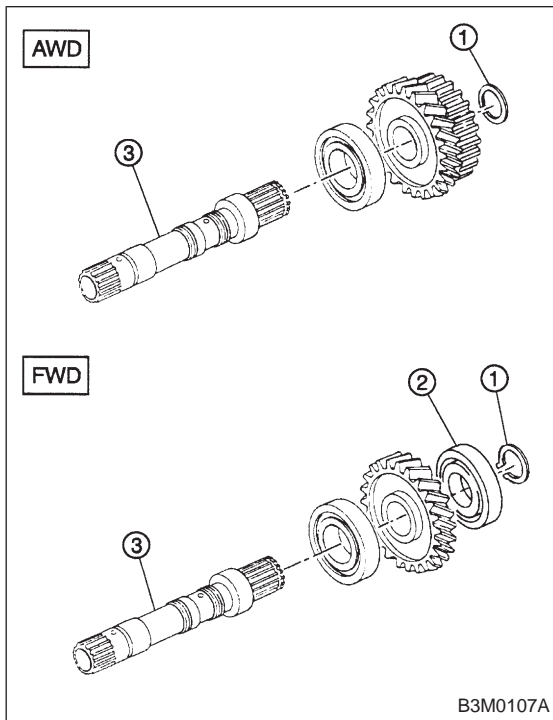

2) AWD: Fit the snap ring ① securely in the snap ring groove on the shaft ③.

FWD: Press ball bearing ② into place and secure snap ring ① to groove in shaft ③.

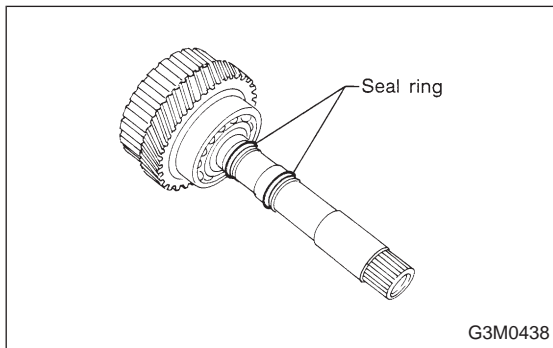

3) Attach two seal rings.

**NOTE:**

To make subsequent assembly easier, apply vaseline to the grooves of the shaft and to the exterior of the seal ring.