

## 15. Transfer Clutch

### A: DISASSEMBLY

1) Remove the seal ring.

**CAUTION:**

Be careful not to damage the seal ring.

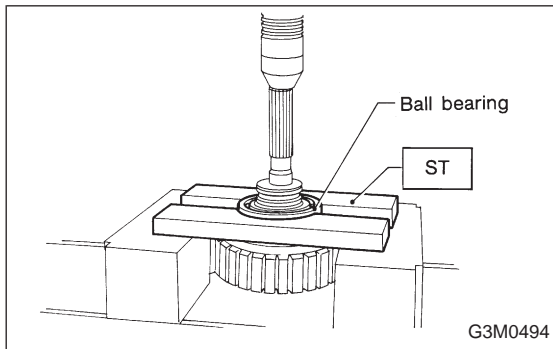

2) Using a press and ST, remove the ball bearing.

ST 498077000 REMOVER

**CAUTION:**

Do not reuse the bearing.

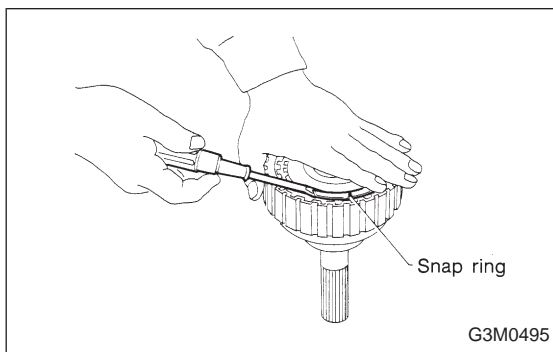

3) Remove the snap ring, and take out the pressure plate, drive plates, and driven plates.

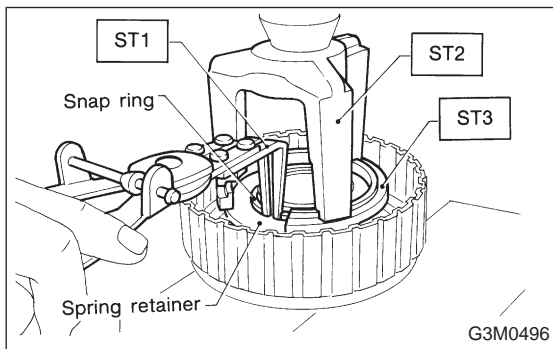

4) Remove the snap ring with ST1, ST2 and ST3, and take out the spring retainer.

ST1 399893600 PLIERS

ST2 398673600 COMPRESSOR

ST3 498627000 SEAT

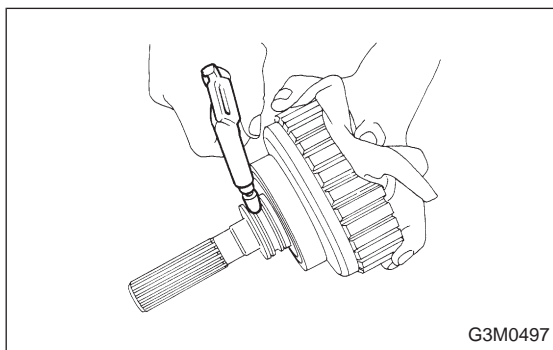

5) Apply compressed air to the rear drive shaft to remove the piston.

**B: INSPECTION**

- 1) Check the drive plate facing for wear and damage.
- 2) Check the snap ring for wear, return spring for permanent set and breakage, and spring retainer for deformation.
- 3) Check the lathe cut ring for damage.

**C: ASSEMBLY**

- 1) Install the lathe cut seal ring to the I.D./O.D. of the transfer clutch piston.

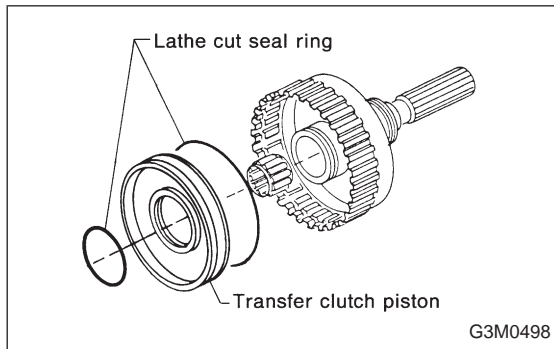

- 2) Install piston.

(1) Connect piston to rear drive shaft (until it reaches hole in valve body).

(2) Install spring retainer to piston.

(3) Using ST1, ST2 and ST3, attach transfer piston seal to ST2.

ST1	499247400	INSTALLER
ST2	499257400	PISTON GUIDE
ST3	498267400	TABLE

**CAUTION:**

**Be careful not to tilt transfer piston seal.**

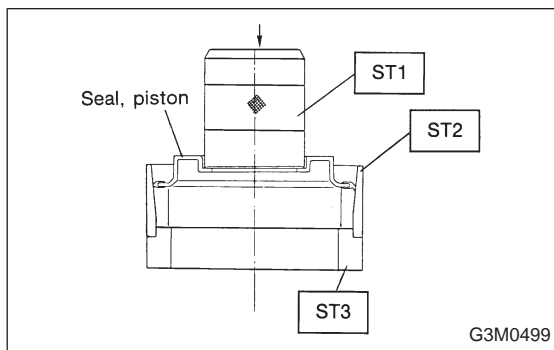

(4) Place ST3 onto rear drive shaft so that spring can be inserted into hole in transfer piston seal.

(5) Attach ST2 to rear drive shaft. Using ST1, press into place.

ST1	499247400	INSTALLER
ST2	499257300	SNAP RING OUTER GUIDE
ST3	499257400	PISTON GUIDE

**CAUTION:**

**Do not allow lip of transfer piston seal to fold back.**

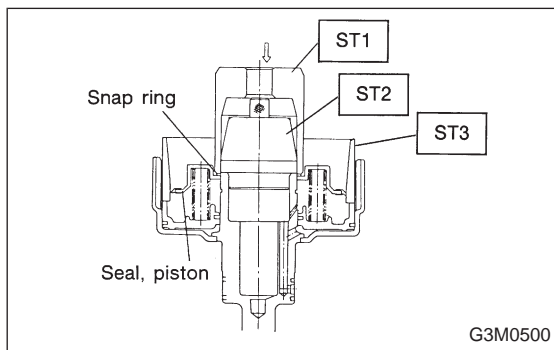

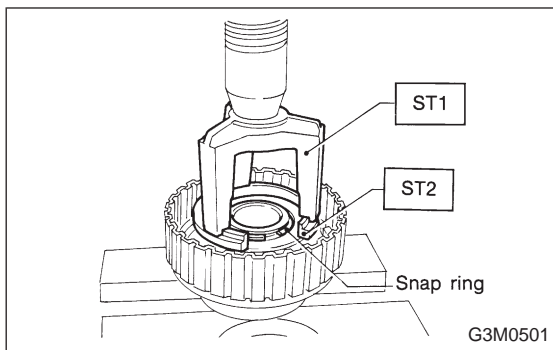

3) Install the driven plates, drive plates, and pressure plate, and secure with a snap ring with ST1, ST2 and a press.

ST1 398673600 COMPRESSOR

ST2 498627000 SEAT

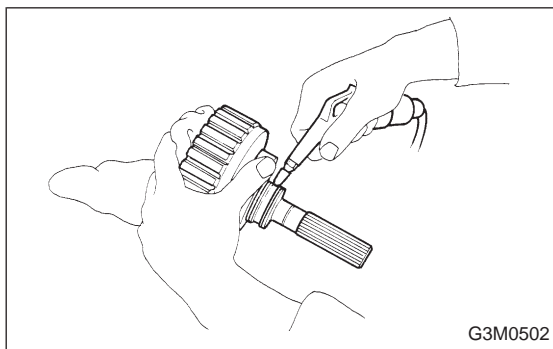

4) Apply compressed air to see if the assembled parts move smoothly.

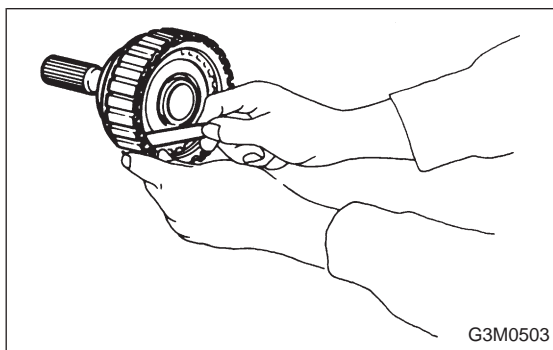

5) Check the clearance.

**Standard value:**

**0.2 — 0.6 mm (0.008 — 0.024 in)**

**Allowable limit:**

**1.6 mm (0.063 in)**

If the clearance is not within the specified range, select a proper pressure plate.

NOTE:

Before measuring clearance, place the same thickness of shim on both sides to prevent pressure plate from tilting.

	Part No.	Thickness mm (in)
● Available pressure plates	31593AA151	3.3 (0.130)
	31593AA161	3.7 (0.146)
	31593AA171	4.1 (0.161)
	31593AA181	4.5 (0.177)

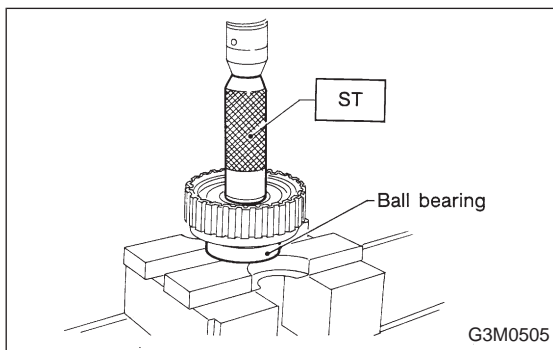

6) Press-fit the ball bearing with ST.

ST 899580100 INSTALLER

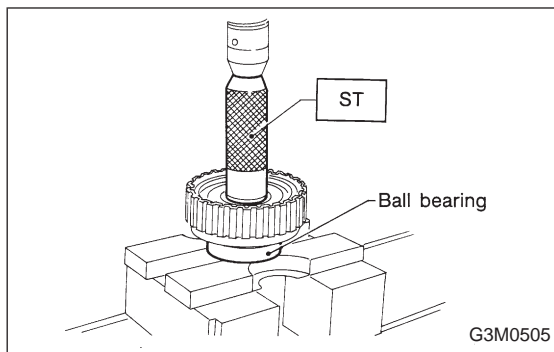

7) Coat the seal ring with vaseline, and install it in the seal ring groove of the shaft.

**CAUTION:**

**Do not expand the seal ring excessively when installing.**

ST 899580100 INSTALLER

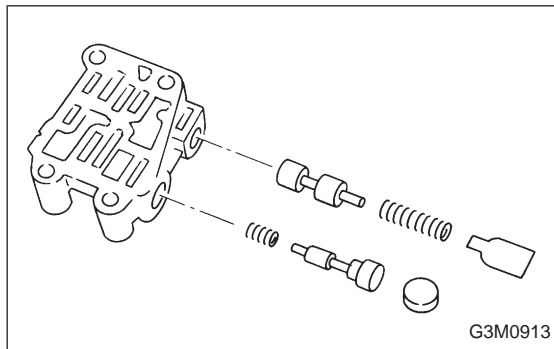

## 16. Transfer Valve Body

### A: DISASSEMBLY

1) Remove the plate. Then remove the spring and pilot valve together.

2) Remove the straight pin and pry out the plug with a screwdriver. Then extract the spring and transfer clutch valve together.

**CAUTION:**

**Be careful not to damage the valve and valve body.**

### B: INSPECTION

Check each component for harmful cuts, damage, or other faults.

### C: ASSEMBLY

To assemble, reverse the removal sequence.

**NOTE:**

Make sure the valve slides smoothly after assembling.