■ Expectant mothers

Expectant mothers also need to use the seat belts. They should consult their doctor for specific recommendations. The lap belt should be worn securely and as low as possible over the hips, not over the waist.

■ Maintenance



CAUTION

- **Keep sharp edged or other objects that may cause damage away from belts and other parts of the passenger restraint system.**
- **Keep the belts free of polishes, oils, chemicals and particularly battery acid.**
- **Never attempt to make modifications or changes that will prevent the seat belt from operating properly.**

To clean the seat belts, use a mild soap and lukewarm water. Never bleach or dye the belts because this could seriously affect their strength.

Inspect the seat belts and attachments including the webbing and all hardware periodically for cracks, cuts, gashes, tears, damage, loose bolts or worn areas. Replace the seat belts even if only minor damage is found.

Child restraint system



WARNING

- **Never let a passenger hold a child on his or her lap while the vehicle is moving. The passenger cannot protect the child from injury in a collision, because the child will be caught between the passenger and objects inside the vehicle.**
- **Since your vehicle is equipped with a passenger's side airbag, do not install a rearward facing child seat in the front passenger's seat. Doing so risks serious injury to the child by placing the child's head too close to the SRS AIRBAG. Because of the SRS AIRBAG, we**

strongly recommend that you do not put any type of child seat in the front passenger's seat. If, however, you do install a forward facing child seat in the front passenger's seat, slide the seat to its rear-most position.

Infants and small children should always be placed in an infant or child restraint system while riding in the vehicle. You should use an infant or child restraint system that meets Federal Motor Vehicle Safety Standard and is appropriate for the child's age and size. All child restraint systems are designed to be secured in vehicle seats by lap belts or the lap portion of a lap/shoulder belt.

Children could be endangered in an accident if their child restraints are not properly secured in the vehicle. When installing the child restraint system, carefully follow the manufacturer's instructions.

According to accident statistics, children are safer when properly restrained in the rear seat than the front seat. These statistics also indicate that the safest position for a child restraint system is the center of the rear seat.

■ Rear seat installation

▼ Center position

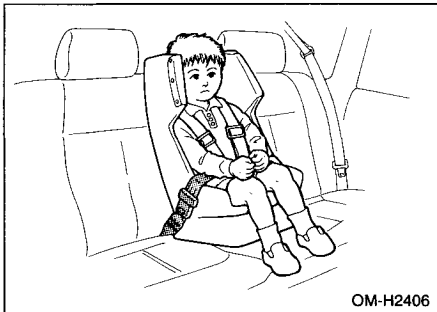

1. Set the child restraint system in the seating position.
2. Fasten the seat belt over the child restraint system.

- CONTINUED -

3. Tighten the belt.

If the child restraint system requires a top strap, latch the hook onto the top strap anchor and tighten the top strap.

▼ Outer position

NOTE

When the child restraint system is no longer in use, remove it and restore the ELR function of the retractor. That function is restored by allowing the seat belt to retract fully.

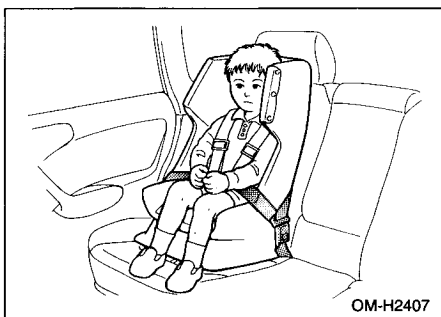

1. Fasten the lap and shoulder belts over the child restraint system.
2. Take up the slack in the lap belt.
3. Put the shoulder portion of the belt between the rear seatback and the child restraint system.
4. Pull out the seat belt fully from the retractor to change the retractor over from the ELR (Emergency Locking Retractor) to the ALR (Automatic Locking Retractor) function. Then, allow the belt to rewind into the retractor. As the belt is rewinding, clicks will be heard which indicate the retractor functions as ALR.
5. Before having a child sit on the child restraint system, move it back and forth to check if it is firmly secured.
6. Pull at the shoulder portion of the belt to confirm that it cannot be pulled out (ALR properly functioning).

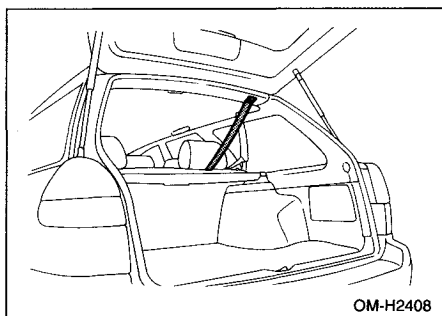

If the child restraint system requires a top strap, latch the hook onto the top strap anchor and tighten the top strap.

■ Top strap anchors



CAUTION

Always use a genuine top strap anchor.

▼ Installation point

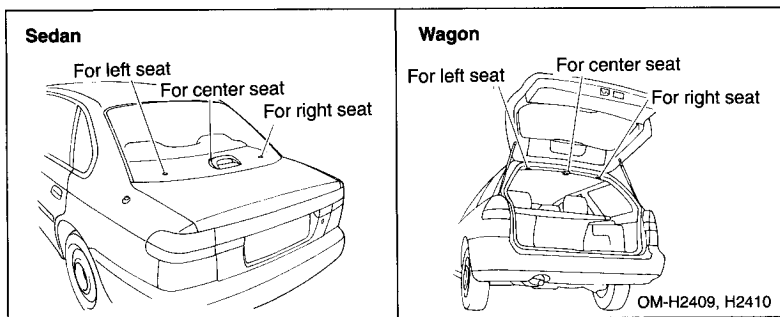

- Sedan: Anchor installation points are located under the covers on the rear shelf.
- Wagon: Anchor installation points are located under the covers at the rear edge of the roof.

- CONTINUED -

▼ Top strap anchor installation (for Canada models)

All vehicles built for sale in Canada include an anchor kit in the glove compartment.

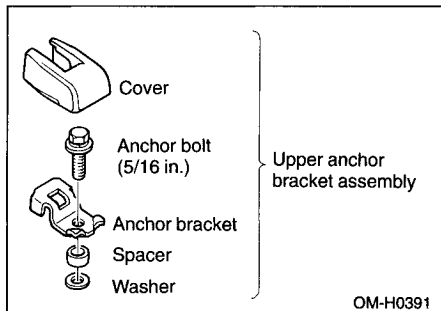

1. Take the anchor kit out and make sure that it is assembled as shown in the illustration above.

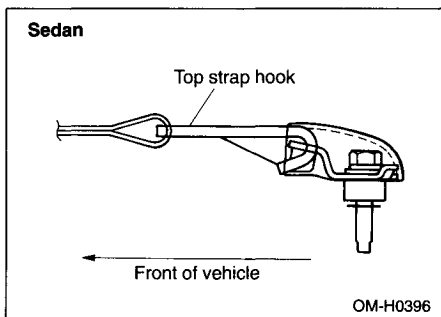

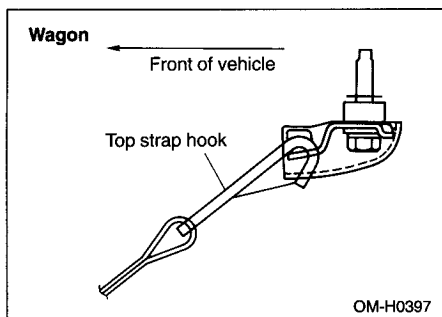

2. Remove the cover of the anchor installation point.
3. Set the anchor at the desired installation point and tighten the bolt until the anchor is firmly secured.
4. Install the anchor plate cover.

Please contact your SUBARU dealer about any questions you may have regarding the installation of the top strap anchor.

▼ Top strap anchor installation (for U.S. models)

Vehicles built for sale in U.S. do not include an anchor kit in the glove compartment. However, the anchor kit and installation instructions are available from your SUBARU dealer. You can also follow the installation instructions for Canada models.

■ Front seat installation

⚠ WARNING

Since your vehicle is equipped with a passenger's side airbag, do not install a rearward facing child seat in the front passenger's seat. Doing so risks serious injury to the child by placing the child's head too close to the SRS AIRBAG. Because of the SRS AIRBAG, we strongly recommend that you do not put any type of child seat in the front passenger's seat. If, however, you do install a forward facing child seat in the front passenger's seat, slide the seat to its rear-most position.

NOTE

When the child restraint system is no longer in use, remove it and restore the ELR function of the retractor. That function is restored by allowing the seat belt to retract fully.

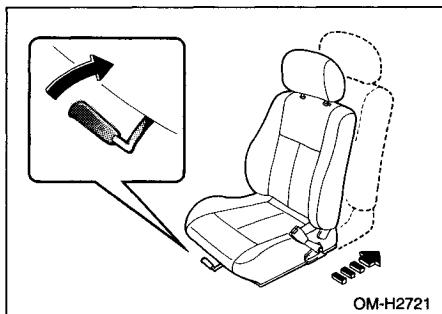

1. Slide the front passenger's seat to the rearmost position while holding the lever up. Then release the lever and move the seat back and forth to make sure that it is securely locked into place.
2. Set the child restraint system in the seating position.
3. Fasten the lap and shoulder belts over the child restraint system.
4. Take up the slack in the lap belt.

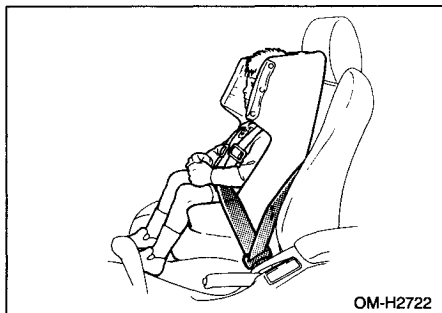

5. Put the shoulder portion of the belt between the seatback and the child restraint system.

6. Pull out the seat belt fully from the retractor to change the retractor over from the ELR (Emergency Locking Retractor) to the ALR (Automatic Locking Retractor) function. Then, allow the belt to rewind into the retractor. As the belt is rewinding, clicks will be heard which indicate the retractor functions as ALR.
7. Before having a child sit on the child restraint system, move it back and forth to check if it is firmly secured.
8. Pull at the shoulder portion of the belt to confirm that it cannot be pulled out (ALR properly functioning).

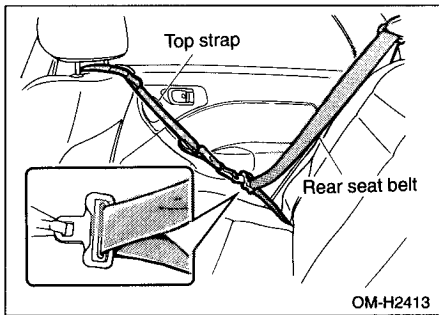

If the child restraint system requires a top strap, pull out the rear seat belt fully from the retractor to change the retractor over from ELR (Emergency Locking Retractor) to the ALR (Automatic Locking Retractor) function. Then latch the hook onto the tongue hole and take a slack of the top strap by allowing the seat belt rewind until it stops. As the belt is rewinding, clicks will be heard which indicate the retractor functions as ALR. Before having a child sit on the child restraint system, pull at the shoulder portion of the belt to confirm it cannot be pulled out.