

10. Diagnostics Chart with Trouble Code

A: DIAGNOSTIC TROUBLE CODE (DTC) LIST

DTC No.	Abbreviation (Subaru select monitor)	Item	Page
P0100	QA	Mass air flow sensor circuit malfunction	*1
P0101	QA — R	Mass air flow sensor circuit range/performance problem	*1
P0105	P — S	Pressure sensor circuit malfunction	*1
P0106	PS — R	Pressure sensor circuit range/performance problem	*1
P0115	TW	Engine coolant temperature sensor circuit malfunction	*1
P0120	THV	Throttle position sensor circuit malfunction	*1
P0121	TH — R	Throttle position sensor circuit range/performance problem	*1
P0125	TW — CL	Insufficient coolant temperature for closed loop fuel control	*1
P0130	FO2 — V	Front oxygen sensor circuit malfunction	*1
P0133	FO2 — R	Front oxygen sensor circuit slow response	*1
P0135	FO2H	Front oxygen sensor heater circuit malfunction	*1
P0136	RO2 — V	Rear oxygen sensor circuit malfunction	*1
P0139	RO2 — R	Rear oxygen sensor circuit slow response	*1
P0141	RO2H	Rear oxygen sensor heater circuit malfunction	*1
P0170	FUEL	Fuel trim malfunction	*1
P0180	TNKT	Fuel temperature sensor A circuit malfunction	10
P0181	TNKT — F	Fuel temperature sensor A circuit range/performance problem	16
P0201	INJ1	Fuel injector circuit malfunction - #1	*1
P0202	INJ2	Fuel injector circuit malfunction - #2	
P0203	INJ3	Fuel injector circuit malfunction - #3	
P0204	INJ4	Fuel injector circuit malfunction - #4	
P0301	MIS — 1	Cylinder 1 misfire detected	*1
P0302	MIS — 2	Cylinder 2 misfire detected	
P0303	MIS — 3	Cylinder 3 misfire detected	
P0304	MIS — 4	Cylinder 4 misfire detected	
P0325	KNOCK	Knock sensor circuit malfunction	*1
P0335	CRANK	Crankshaft position sensor circuit malfunction	*1
P0340	CAM	Camshaft position sensor circuit malfunction	*1
P0400	EGR	Exhaust gas recirculation flow malfunction	*1
P0403	EGRSOL	Exhaust gas recirculation circuit malfunction	*1
P0420	CAT	Catalyst system efficiency below threshold	*1
P0440	EVAP	Evaporative emission control system malfunction	18
P0441	CPC — F	Evaporative emission control system incorrect purge flow	*1
P0443	CPC	Evaporative emission control system purge control valve circuit malfunction	*1
P0446	VCMSOL	Evaporative emission control system vent control malfunction	22
P0450	TNKP	Evaporative emission control system pressure sensor malfunction	28
P0451	TNKP — F	Evaporative emission control system pressure sensor range/performance problem	36

*1: <Ref. to 2-7 [T11A0].☆4>

DTC No.	Abbreviation (Subaru select monitor)	Item	Page
P0500	VSP	Vehicle speed sensor malfunction	*1
P0505	ISC	Idle control system malfunction	*1
P0506	ISC — L	Idle control system RPM lower than expected	*1
P0507	ISC — H	Idle control system RPM higher than expected	*1
P0600	—	Serial communication link malfunction	*1
P0601	RAM	Internal control module memory check sum error	*1
P0703	ATBRK	Brake switch input malfunction	*1
P0705	ATRNG	Transmission range sensor circuit malfunction	*1
P0710	ATF	Transmission fluid temperature sensor circuit malfunction	*1
P0720	ATVSP	Output speed sensor (vehicle speed sensor 1) circuit malfunction	*1
P0725	ATNE	Engine speed input circuit malfunction	*1
P0731	ATGR1	Gear 1 incorrect ratio	*1
P0732	ATGR2	Gear 2 incorrect ratio	
P0733	ATGR3	Gear 3 incorrect ratio	
P0734	ATGR4	Gear 4 incorrect ratio	
P0740	ATLU — F	Torque converter clutch system malfunction	*1
P0743	ATLU	Torque converter clutch system electrical	*1
P0748	ATPL	Pressure control solenoid electrical	*1
P0753	ATSFT1	Shift solenoid A electrical	*1
P0758	ATSFT2	Shift solenoid B electrical	*1
P0760	ATOVR — F	Shift solenoid C malfunction	*1
P0763	ATOVR	Shift solenoid C electrical	*1
P1100	ST — SW	Starter switch circuit malfunction	*1
P1101	N/P — SW	Neutral position switch circuit malfunction [MT vehicles]	*1
P1101	N/P — SW	Neutral position switch circuit malfunction [AT vehicles]	*1
P1102	BR	Pressure sources switching solenoid valve circuit malfunction	*1
P1103	TRQ	Engine torque control signal circuit malfunction	*1
P1400	PCVSOL	Fuel tank pressure control solenoid valve circuit malfunction	38
P1401	PCV — F	Fuel tank pressure control system function problem	44
P1402	FLVL	Fuel level sensor circuit malfunction	46
P1500	FAN — 1	Radiator fan relay 1 circuit malfunction	*1
P1502	FAN — F	Radiator fan function problem	*1
P1700	ATTH	Throttle position sensor circuit malfunction for automatic transmission	*1
P1701	ATCRS	Cruise control set signal circuit malfunction for automatic transmission	*1
P1702	ATDIAG	Automatic transmission diagnosis input signal circuit malfunction	*1
P0461*2	EXERR22	Fuel level sensor circuit range/performance problem	56

*1: <Ref. to 2-7 [T11A0].☆4>

*2: Only OBD-II general scan tool displays DTC.

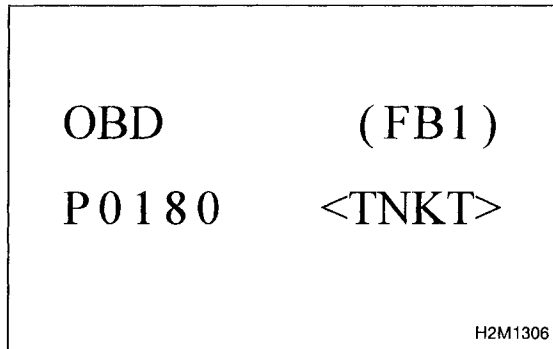

BO: DTC P0180
— FUEL TEMPERATURE SENSOR A CIRCUIT MALFUNCTION (TNKT) —

- DTC DETECTING CONDITION:**
- Immediately at fault recognition

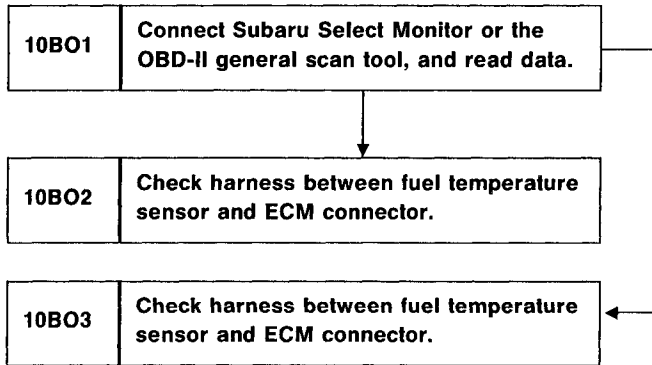

CAUTION:
 After repair or replacement of faulty parts, conduct **CLEAR MEMORY** and **INSPECTION MODES**.
 < Ref. to 2-7 [T3D0] and [T3E0].☆2 and ☆4 >

WIRING DIAGRAM:

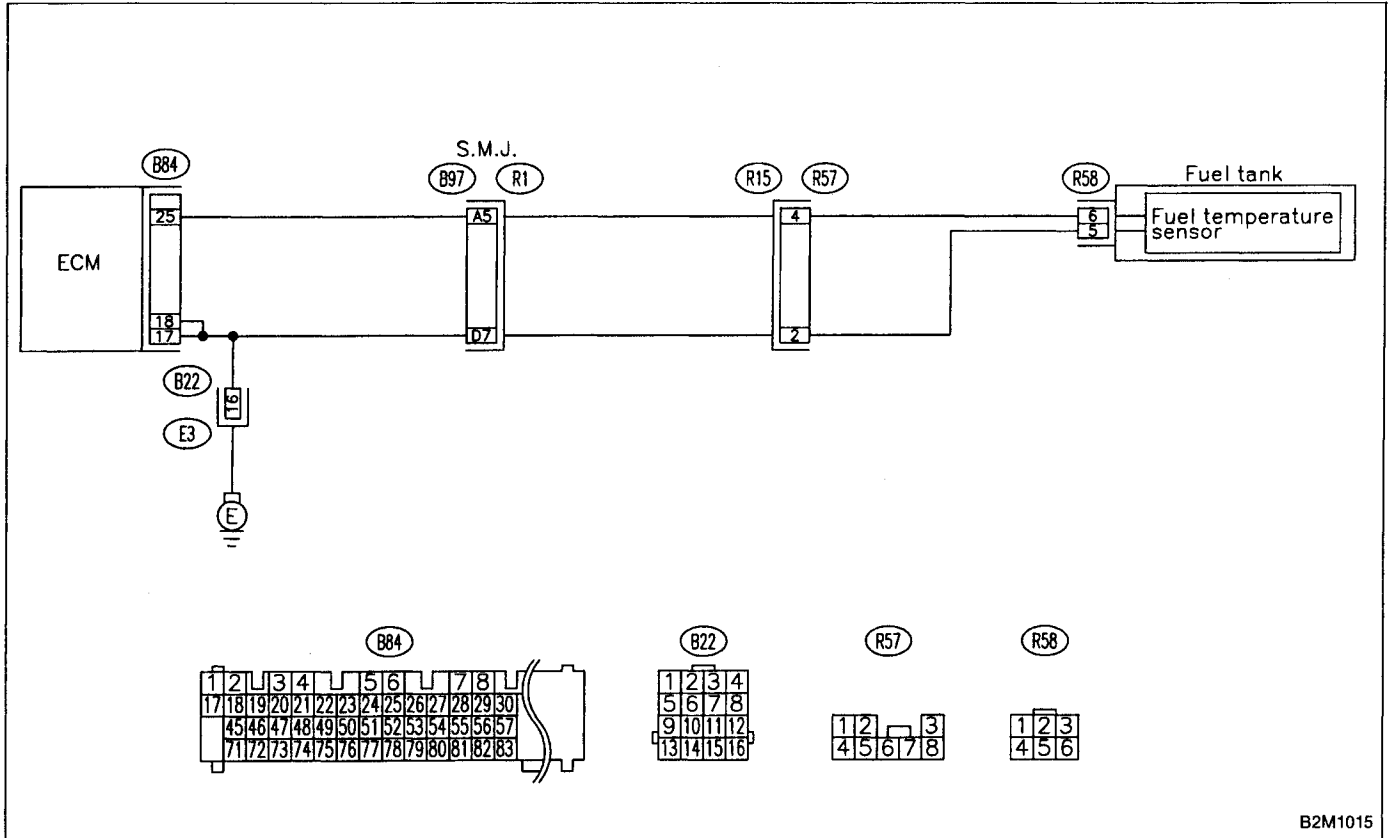

B2M1015

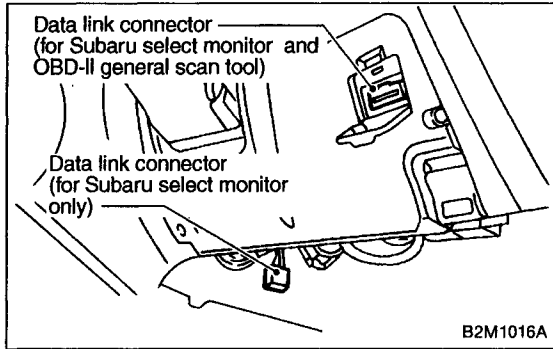

10B01 CONNECT SUBARU SELECT MONITOR OR THE OBD-II GENERAL SCAN TOOL, AND READ DATA.

- 1) Turn ignition switch to OFF.
- 2) Connect Subaru Select Monitor or the OBD-II general scan tool to data link connector.
- 3) Turn ignition switch to ON and Subaru Select Monitor or OBD-II general scan tool switch to ON.
- 4) Start engine.

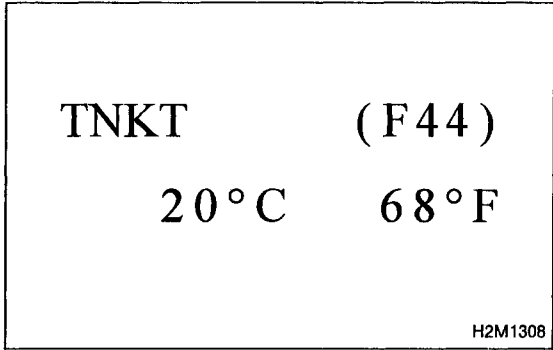

- 5) Read data on Subaru Select Monitor or OBD-II general scan tool.

- Subaru Select Monitor Designate mode using function key.

Function mode: F44

- F44: Fuel temperature is indicated in "°C" and "°F".

CHECK : Is the value greater than 150°C or 300°F in function mode F44?

YES : Go to step 10B02.

NO : Go to next **CHECK**.

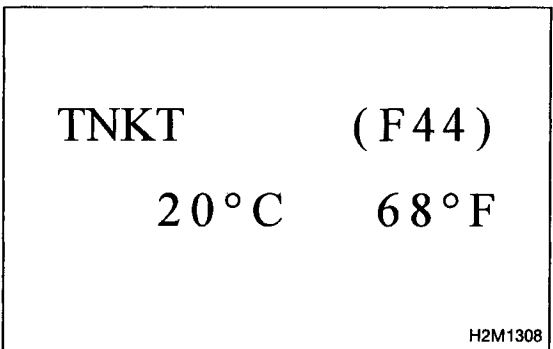

CHECK : Is the value less than -40°C or -40°F in function mode F44?

YES : Go to step 10B03.

NO : Repair poor contact.

NOTE:

In this case, repair the following:

- Poor contact in fuel pump connector
- Poor contact in ECM connector
- Poor contact in coupling connector (B22, B97 and R57)
- OBD-II general scan tool

For detailed operation procedures, refer to the OBD-II General Scan Tool Instruction Manual.

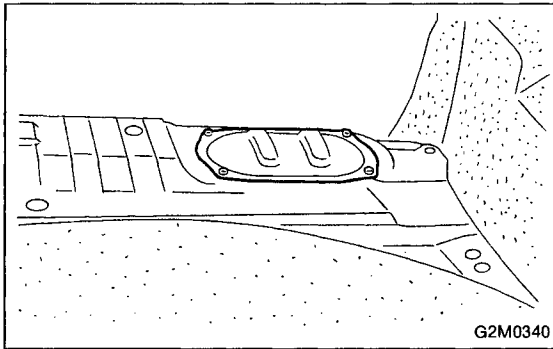

10B02 **CHECK HARNESS BETWEEN FUEL TEMPERATURE SENSOR AND ECM CONNECTOR.**

- 1) Turn ignition switch to OFF.
- 2) Remove access hole lid.
- 3) Disconnect connector from fuel pump.

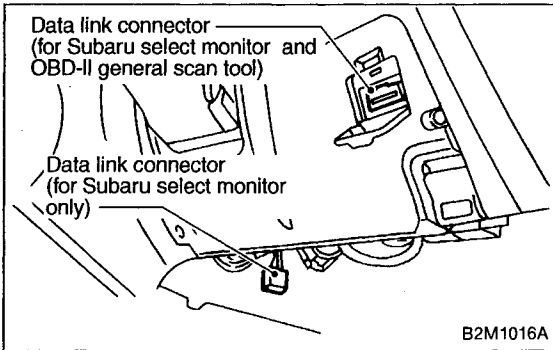

- 4) Connect Subaru Select Monitor or the OBD-II general scan tool to data link connector.
- 5) Turn ignition switch and Subaru Select Monitor or OBD-II general scan tool switch to ON.

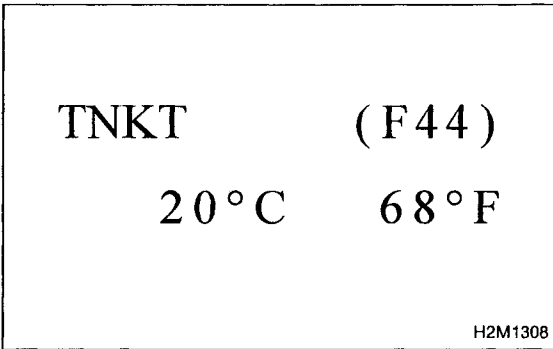

- 6) Read data on Subaru Select Monitor or the OBD-II general scan tool.

● Subaru Select Monitor
Designate mode using function key.

Function mode: F44

● F44: Fuel temperature is indicated in "°C" and "°F".

CHECK : **Is the value less than -40°C or -40°F in function mode F44?**

YES : Replace fuel temperature sensor.

NO : Repair short circuit in harness between fuel pump and ECM connector.

● OBD-II general scan tool
For detailed operation procedures, refer to the OBD-II General Scan Tool Instruction Manual.

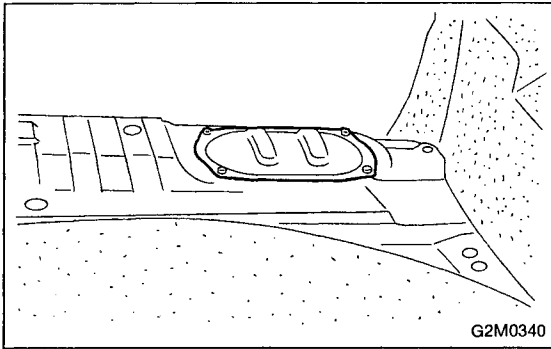

10B03 CHECK HARNESS BETWEEN FUEL TEMPERATURE SENSOR AND ECM CONNECTOR.

- 1) Turn ignition switch to OFF.
- 2) Remove access hole lid.
- 3) Disconnect connector from fuel pump.
- 4) Turn ignition switch to ON.

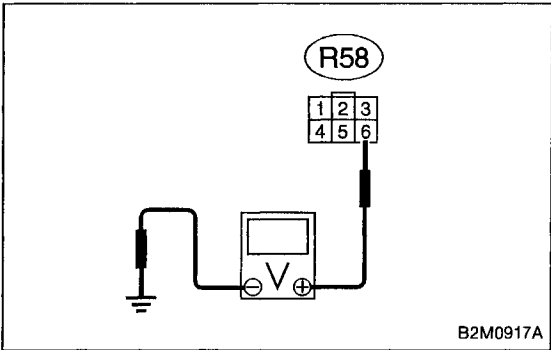

- 5) Measure voltage between fuel pump connector and chassis ground.

CHECK : **Connector & terminal (R58) No. 6 (+) — Chassis ground (-): Is the voltage more than 4 V?**

YES : Go to next step 6).

NO : Repair harness and connector.

NOTE:

In this case, repair the following:

- Open circuit in harness between ECM and fuel pump connector
- Poor contact in fuel pump connector
- Poor contact in ECM connector
- Poor contact in coupling connectors (B97 and R57)

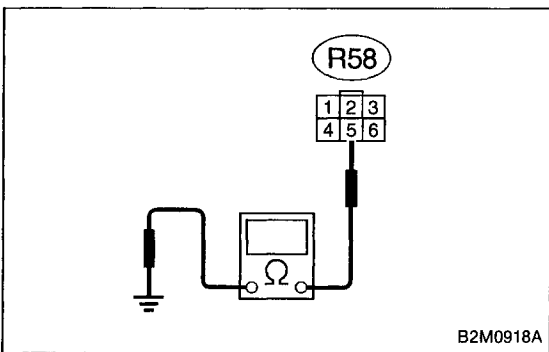

- 6) Turn ignition switch to OFF.
- 7) Measure resistance of harness between fuel pump connector and chassis ground.

CHECK : **Connector & terminal (R58) No. 5 — Chassis ground: Is the resistance less than 5 Ω?**

YES : Replace fuel temperature sensor.

NO : Repair harness and connector.

NOTE:

In this case, repair the following:

- Open circuit in harness between ECM and fuel pump connector
- Poor contact in fuel pump connector
- Poor contact in ECM connector
- Poor contact in coupling connectors (B22, B97 and R57)

MEMO:

OBD (FB1)
P0181 <TNKT_F>

H2M1350

BP: DTC P0181
— FUEL TEMPERATURE SENSOR A CIRCUIT
RANGE/PERFORMANCE PROBLEM
(TNKT — F) —

DTC DETECTING CONDITION:

- Two consecutive trips with fault

10BP1 | Check DTC P0180 on display.

CAUTION:

After repair or replacement of faulty parts, conduct **CLEAR MEMORY** and **INSPECTION MODES**.

< Ref. to 2-7 [T3D0] and [T3E0].☆2 and ☆4 >

WIRING DIAGRAM:

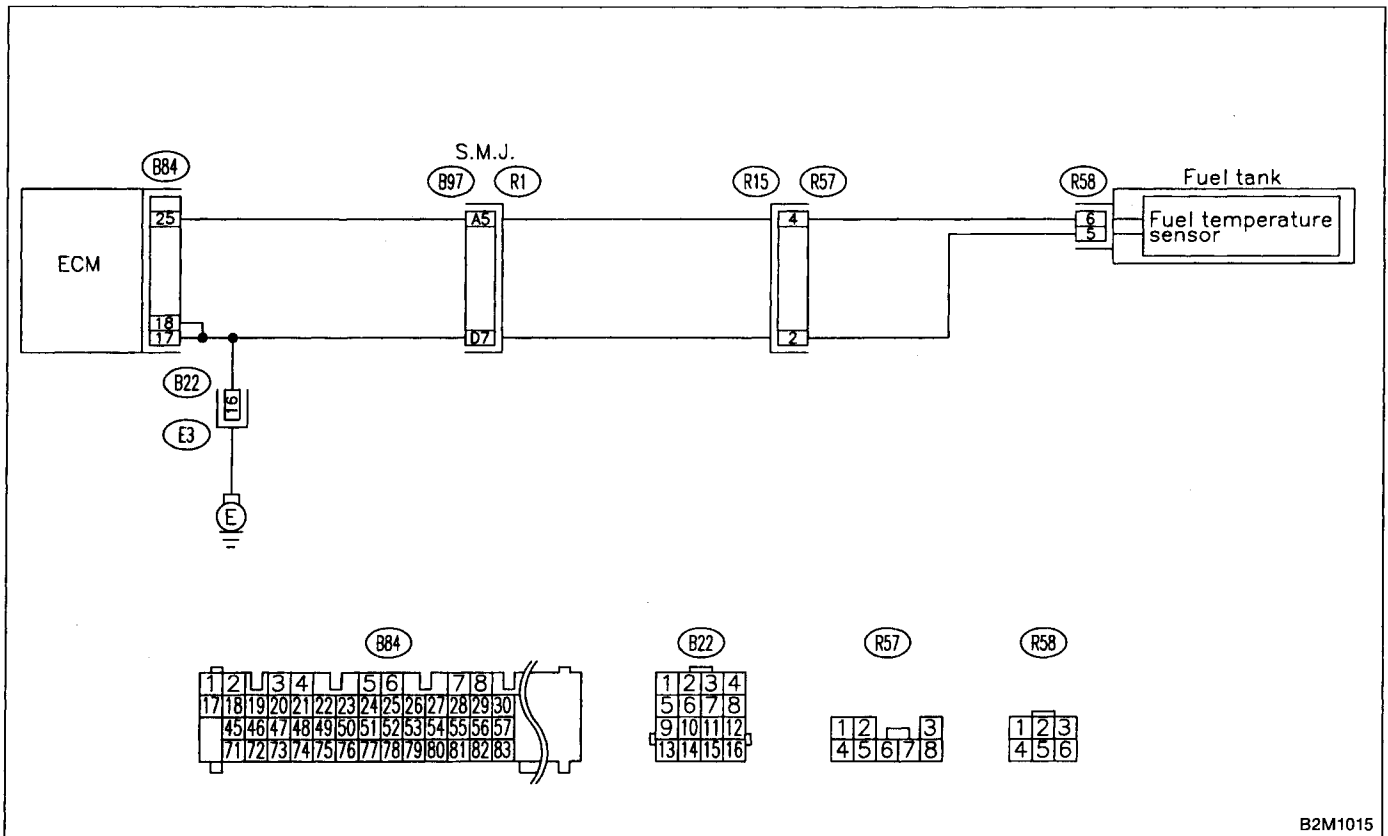

B2M1015

10BP1	CHECK DTC P0180 ON DISPLAY.
--------------	------------------------------------

CHECK : *Does the Subaru select monitor or OBD-II general scan tool indicate DTC P0180?*

YES : Inspect DTC P0180 using "10. Diagnostics Chart with Trouble Code 2-7 [T10A0]"☆7.

NOTE:

In this case, it is not necessary to inspect DTC P0181.

NO : Replace fuel temperature sensor.

<p>OBD (FB1)</p> <p>P0440 <EVAP></p> <p style="text-align: right; font-size: small;">H2M1365</p>
--

BQ: DTC P0440
— EVAPORATIVE EMISSION CONTROL SYSTEM MALFUNCTION (EVAP) —

DTC DETECTING CONDITION:

- Two consecutive trips with fault

TROUBLE SYMPTOM:

- Gasoline smell

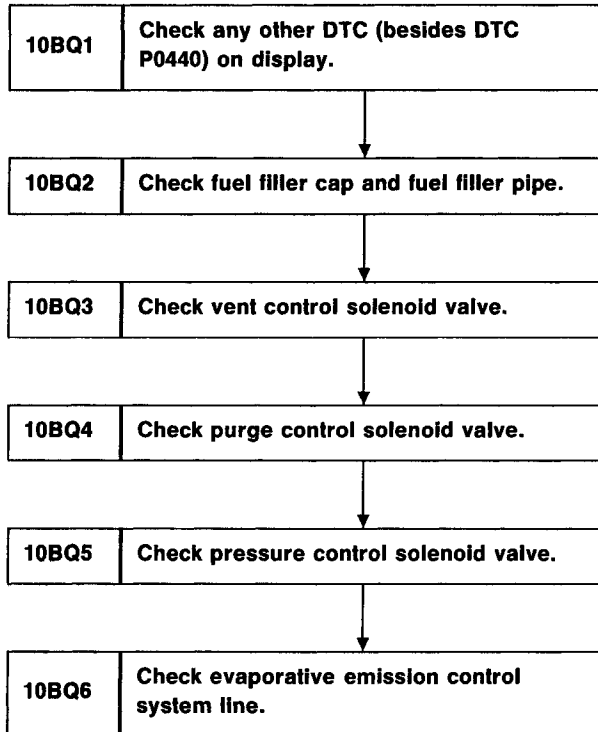

CAUTION:

After repair or replacement of faulty parts, conduct CLEAR MEMORY and INSPECTION MODES.

< Ref. to 2-7 [T3D0] and [T3E0].☆2 and ☆4 >

WIRING DIAGRAM:

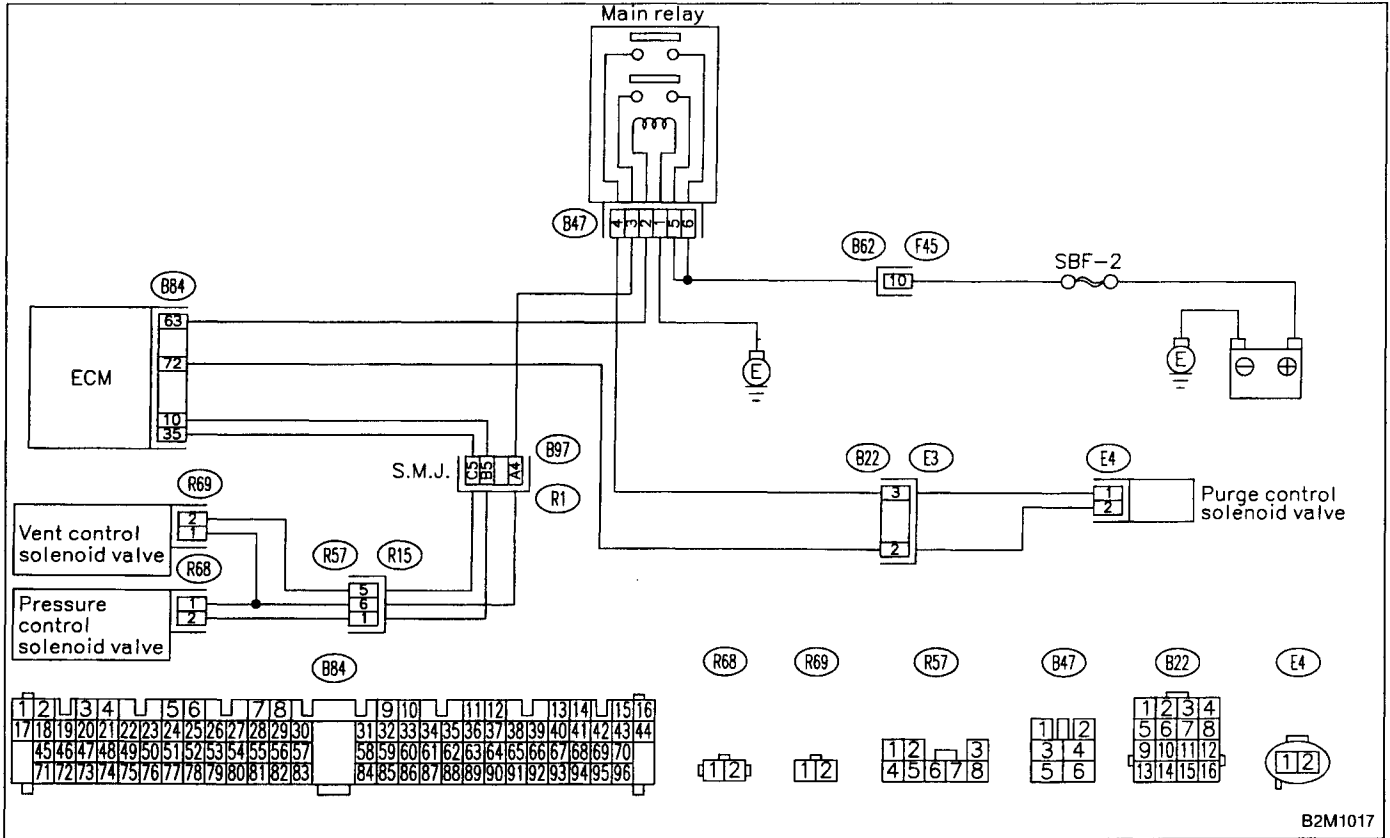

B2M1017

10BQ1 CHECK ANY OTHER DTC (BESIDES DTC P0440) ON DISPLAY.

- CHECK** : Is there any other DTC on display?
- YES** : Inspect the relevant DTC using "10. Diagnostics Chart with Trouble Code, 2-7 [T10A0]"☆7.
- NO** : Go to step **10BQ2**.

10BQ2 CHECK FUEL FILLER CAP AND FUEL FILLER PIPE.

- 1) Turn ignition switch to OFF.
 - 2) Open the fuel flap.
- CHECK** : Is the fuel filler cap tightened securely?
 - YES** : Tighten fuel filler cap securely.
 - NO** : Go to next **CHECK** .

CHECK : Is there any damage to the seal between fuel filler cap and fuel filler pipe?

YES : Repair or replace fuel filler cap and fuel filler pipe.

NO : Go to step **10BQ3**.

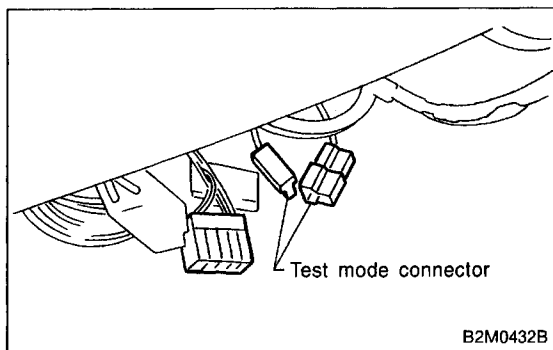

10BQ3 CHECK VENT CONTROL SOLENOID VALVE.

- 1) Connect test mode connector.
- 2) Turn ignition switch to ON.

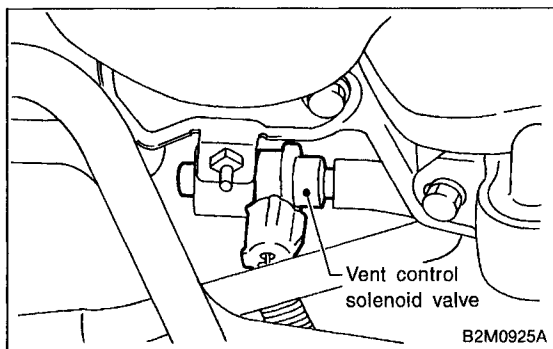

CHECK : Does vent control solenoid valve produce operating sound?

NOTE:

Vent control solenoid valve operation check can also be executed using Subaru Select Monitor (Function mode: FD08). For the procedure, refer to "COMPULSORY VALVE OPERATION CHECK MODE" 2-7 [T3F0]☆4.

YES : Go to step **10BQ4**.

NO : Replace vent control solenoid valve.

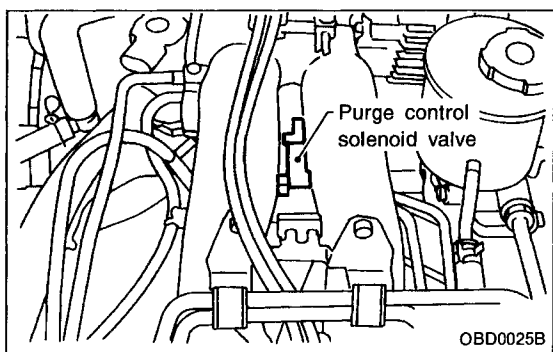

10BQ4 CHECK PURGE CONTROL SOLENOID VALVE.

CHECK : Does purge control solenoid valve produce operating sound?

NOTE:

Purge control solenoid valve operation check can also be executed using Subaru Select Monitor (Function mode: FD02). For the procedure, refer to "COMPULSORY VALVE OPERATION CHECK MODE" 2-7 [T3F0]☆4.

YES : Go to step **10BQ5**.

NO : Replace purge control solenoid valve.

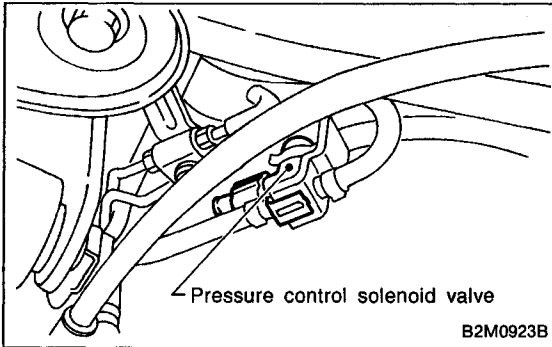

10BQ5	CHECK PRESSURE CONTROL SOLENOID VALVE.
--------------	---

CHECK : **Does pressure control solenoid valve produce operating sound?**

NOTE:

Pressure control solenoid valve operation check can also be executed using Subaru Select Monitor (Function mode: FD07). For the procedure, refer to "COMPULSORY VALVE OPERATION CHECK MODE" 2-7 [T3F0]☆4.

YES : Go to step **10BQ6**.

NO : Replace pressure control solenoid valve.

10BQ6	CHECK EVAPORATIVE EMISSION CONTROL SYSTEM LINE.
--------------	--

Turn ignition switch to OFF.

CHECK : **Does fuel leak in fuel line?**

YES : Repair or replace fuel line.

NO : Go to next **CHECK** .

CHECK : **Is there any damage at canister?**

YES : Repair or replace canister.

NO : Go to next **CHECK** .

CHECK : **Is there any damage at fuel tank?**

YES : Repair or replace fuel tank.

NO : Go to next **CHECK** .

CHECK : **Are there holes, cracks, clogging or disconnections of hoses or pipes in evaporative emission control system?**

YES : Repair or replace hoses or pipes.

NO : Contact with SOA service.

NOTE:

Inspection by DTM is required, because probable cause is deterioration of multiple parts.

<p>OBD (FB1)</p> <p>P0446 <VCMSOL></p> <p style="text-align: right; font-size: small;">H2M1368</p>
--

BR: DTC P0446
— EVAPORATIVE EMISSION CONTROL SYSTEM VENT CONTROL MALFUNCTION (VCMSOL) —

DTC DETECTING CONDITION:

- Two consecutive trips with fault

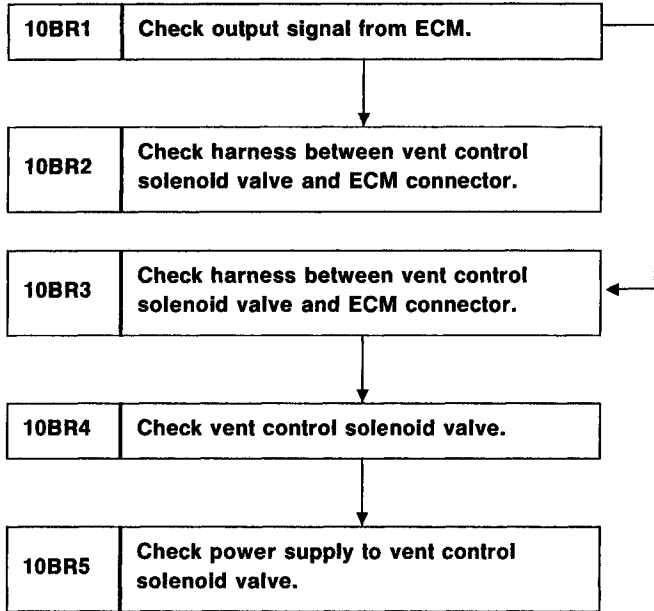

CAUTION:
 After repair or replacement of faulty parts, conduct **CLEAR MEMORY** and **INSPECTION MODES**.
 < Ref. to 2-7 [T3D0] and [T3E0].☆2 and ☆4 >

WIRING DIAGRAM:

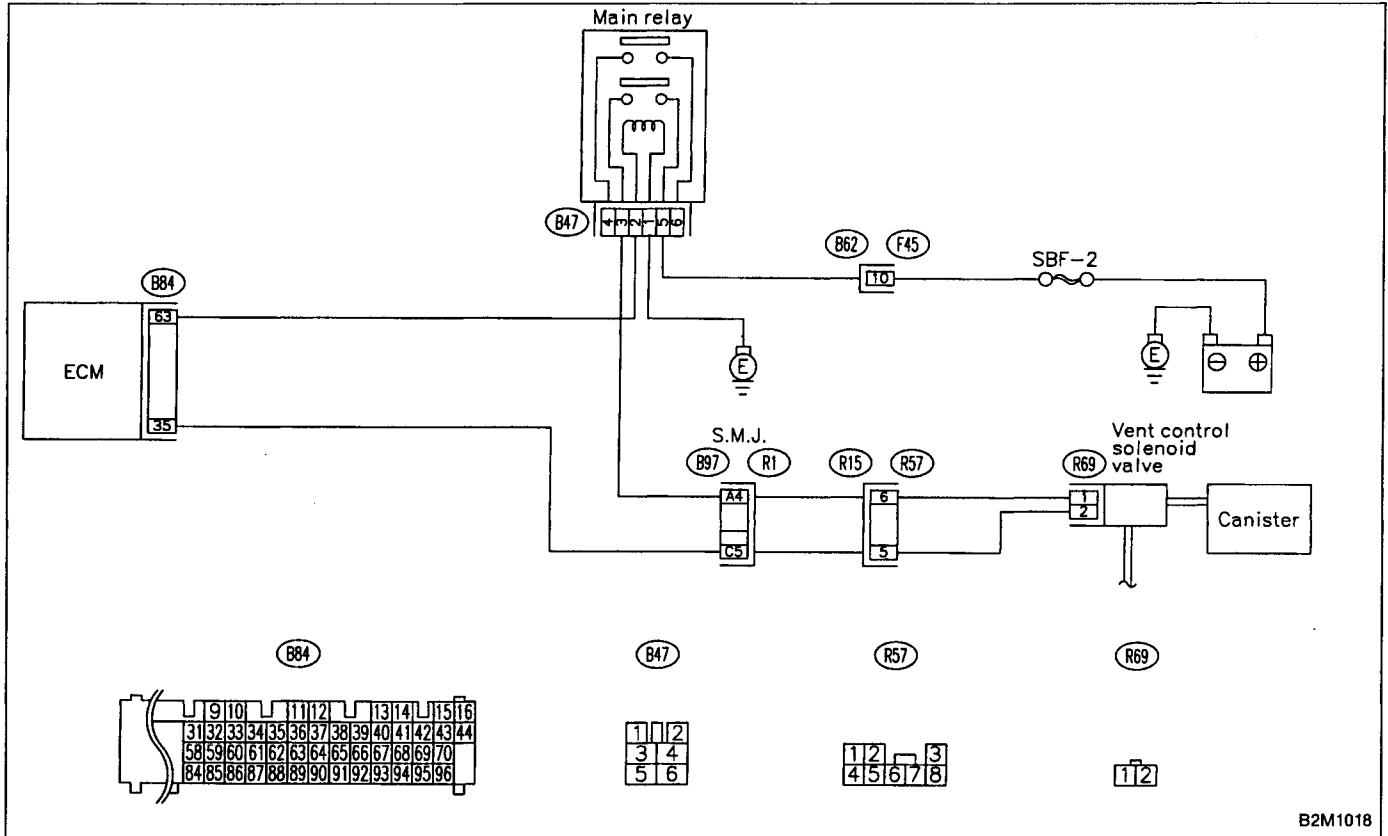

B2M1018

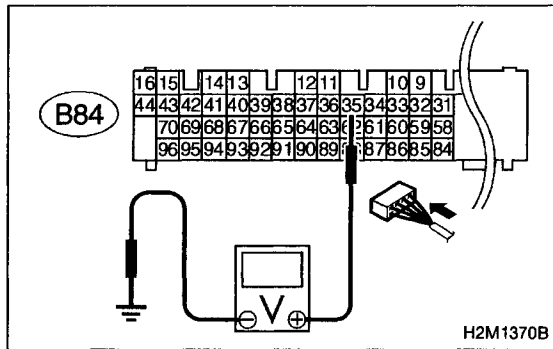

10BR1 CHECK OUTPUT SIGNAL FROM ECM.

- 1) Turn ignition switch to ON.
- 2) Measure voltage between ECM and chassis ground.

CHECK : **Connector & terminal (B84) No. 35 (+) — Chassis ground (-): Is the voltage more than 10 V?**

- YES** : Go to step **10BR2**.
- NO** : Go to step **10BR3**.

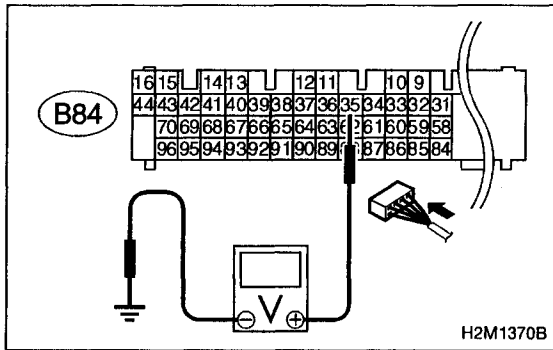

10BR2 CHECK HARNESS BETWEEN VENT CONTROL SOLENOID VALVE AND ECM CONNECTOR.

- 1) Turn ignition switch to OFF.
- 2) Disconnect connector from vent control solenoid valve.
- 3) Turn ignition switch to ON.
- 4) Measure voltage between ECM and chassis ground.

CHECK : **Connector & terminal (B84) No. 35 (+) — Chassis ground (-): Is the voltage more than 10 V?**

- YES** : Repair short circuit in harness and replace ECM.

NOTE:

The harness between ECM and vent control solenoid valve is in short circuit.

- NO** : Go to next step 5).

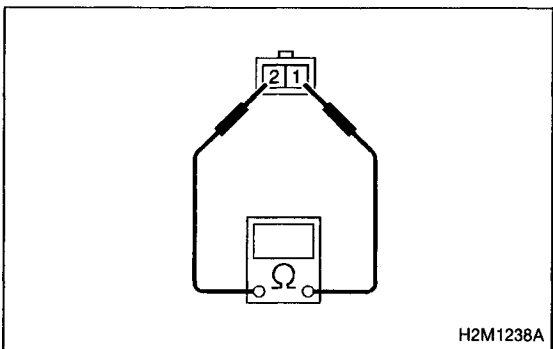

- 5) Turn ignition switch to OFF.
- 6) Measure resistance between vent control solenoid valve terminals.

CHECK : **Terminals No. 1 — No. 2: Is the resistance less than 1 Ω?**

- YES** : Replace vent control solenoid valve and ECM.

- NO** : Go to next **CHECK** .

CHECK : **Is there poor contact in ECM connector?**

- YES** : Repair poor contact in ECM connector.

- NO** : Replace ECM.

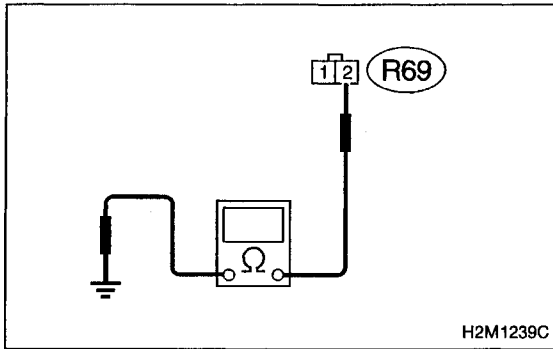

10BR3 CHECK HARNESS BETWEEN VENT CONTROL SOLENOID VALVE AND ECM CONNECTOR.

- 1) Turn ignition switch to OFF.
- 2) Disconnect connectors from vent control solenoid valve and ECM.
- 3) Measure resistance of harness between vent control solenoid valve connector and chassis ground.

CHECK : **Connector & terminal (R69) No. 2 — Chassis ground: Is the resistance less than 10 Ω?**

YES : Repair short circuit in harness between ECM and vent control solenoid valve connector.

NO : Go to next step 4).

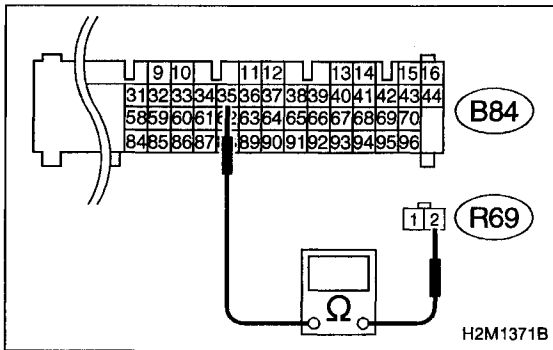

- 4) Measure resistance of harness between ECM and vent control solenoid valve connector.

CHECK : **Connector & terminal (B84) No. 35 — (R69) No. 2: Is the voltage less than 1 Ω?**

YES : Go to step 10BR4.

NO : Repair harness and connector.

NOTE:

In this case, repair the following:

- Open circuit in harness between ECM and vent control solenoid valve connector
- Poor contact in coupling connectors (B97 and R57)

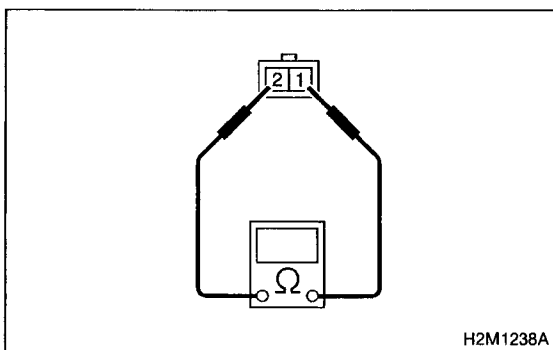

10BR4 CHECK VENT CONTROL SOLENOID VALVE.

Measure resistance between vent control solenoid valve terminals.

CHECK : **Terminals No. 1 — No. 2: Is the resistance between 10 and 100 Ω?**

YES : Go to step 10BR5.

NO : Replace vent control solenoid valve.

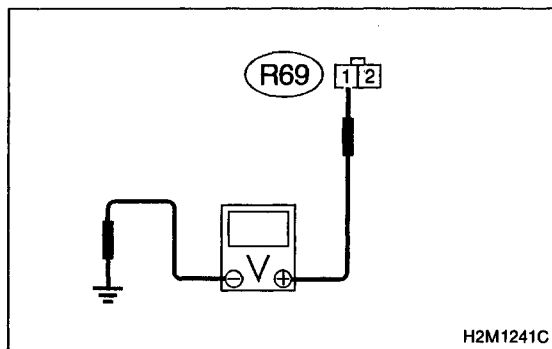
**10BR5****CHECK POWER SUPPLY TO VENT CONTROL SOLENOID VALVE.**

- 1) Turn ignition switch to ON.
- 2) Measure voltage between vent control solenoid valve and chassis ground.

CHECK : **Connector & terminal (R69) No. 1 (+) — Chassis ground (-): Is the voltage more than 10 V?**

YES : Go to next **CHECK** .

NO : Repair harness and connector.

NOTE:

In this case, repair the following:

- Open circuit in harness between main relay and vent control solenoid valve
- Poor contact in coupling connectors (B97 and R57)
- Poor contact in main relay connector

CHECK : **Is there poor contact in vent control solenoid valve connector?**

YES : Repair poor contact in vent control solenoid valve connector.

NO : Contact with SOA service.

NOTE:

Inspection by DTM is required, because probable cause is deterioration of multiple parts.

MEMO:

OBD (FB1) P0450 <TNKP>
H2M1372

BS: DTC P0450
— EVAPORATIVE EMISSION CONTROL SYSTEM PRESSURE SENSOR MALFUNCTION (TNKP) —

DTC DETECTING CONDITION:

- Immediately at fault recognition

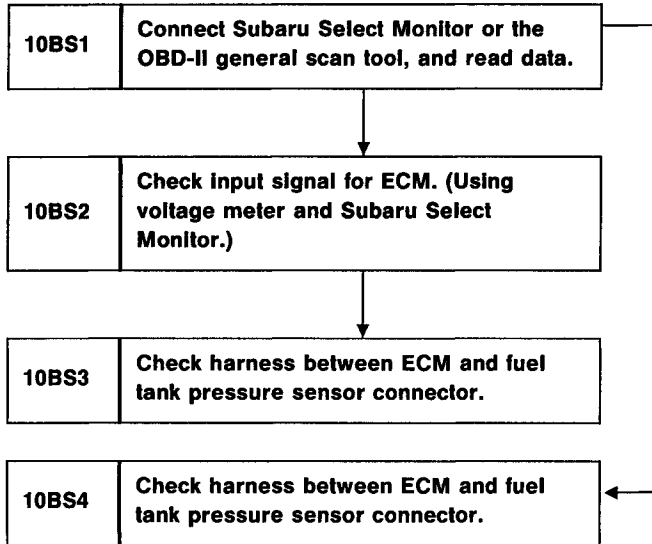

CAUTION:

After repair or replacement of faulty parts, conduct CLEAR MEMORY and INSPECTION MODES.

< Ref. to 2-7 [T3D0] and [T3E0].☆2 and ☆4 >

WIRING DIAGRAM:

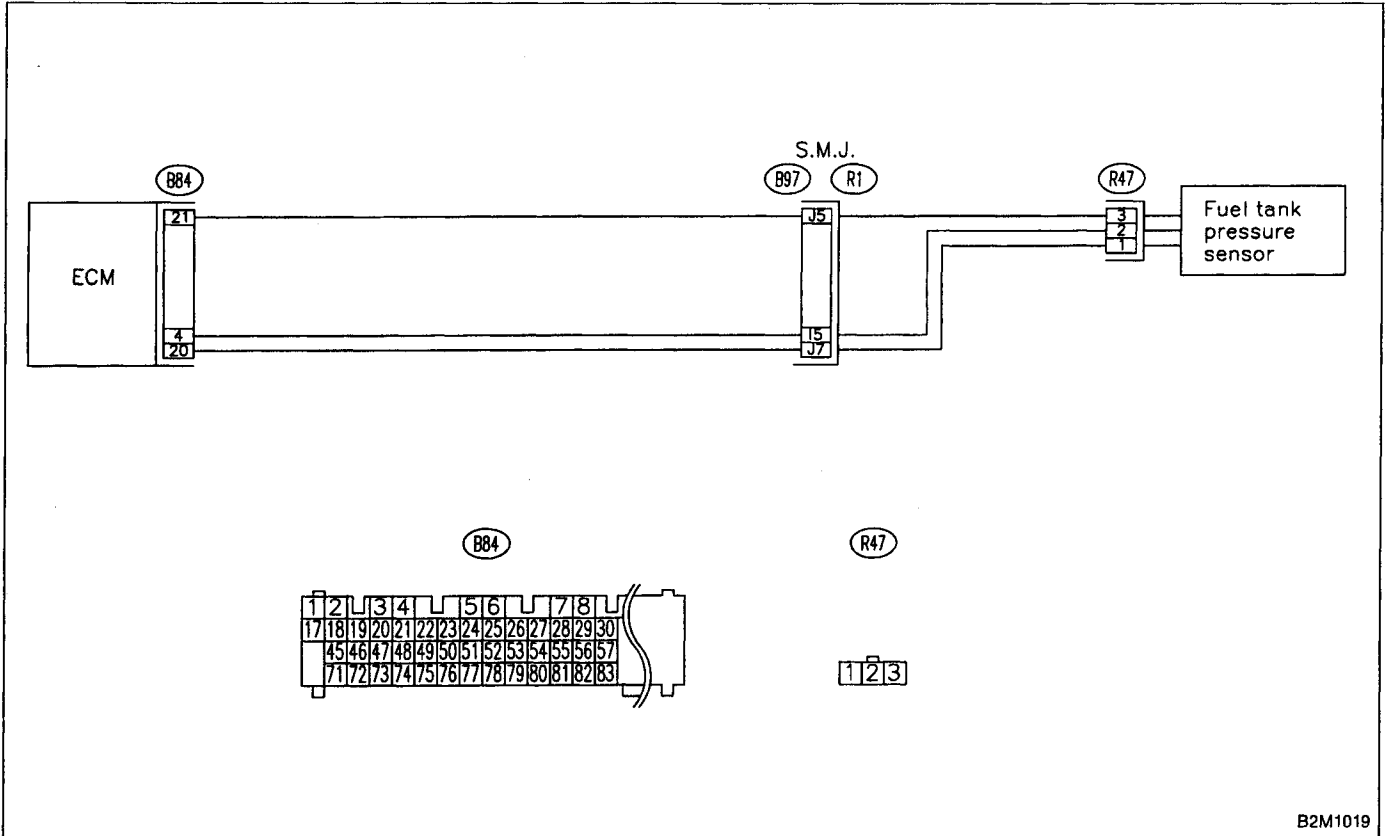

B2M1019

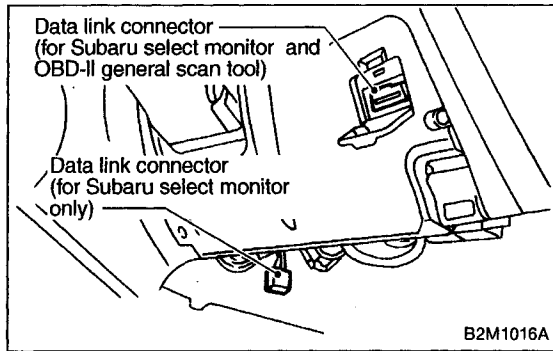

10BS1 **CONNECT SUBARU SELECT MONITOR OR THE OBD-II GENERAL SCAN TOOL, AND READ DATA.**

- 1) Turn ignition switch to OFF.
- 2) Remove fuel filler cap.
- 3) Install fuel filler cap.
- 4) Connect Subaru Select Monitor or the OBD-II general scan tool to data link connector.
- 5) Turn ignition switch to ON and Subaru Select Monitor or the OBD-II general scan tool switch to ON.
- 6) Read the data on Subaru Select Monitor or the OBD-II general scan tool.

● Subaru Select Monitor
Designate mode using function key.

Function mode: F43

● F43: Display shows pressure signal value sent from fuel tank pressure sensor.

CHECK : *Is the value less than -2.8 kPa in function mode F43?*

YES : Go to step **10BS2**.

NO : Go to next **CHECK** .

TNKP (F43)

0. 10kPa 1mmHg

H2M1326

TNKP (F43)

0. 10kPa 1mmHg

H2M1326

CHECK : *Is the value more than 2.8 kPa in function mode F43?*

YES : Go to step **10BS4**.

NO : Repair harness and connector.

NOTE:

In this case, repair the following:

- Open or short circuit in harness between fuel tank pressure sensor and ECM connector
- Poor contact in coupling connector (B97)
- Poor contact in fuel tank pressure sensor
- Poor contact in ECM connector
- OBD-II general scan tool

For detailed operation procedures, refer to the OBD-II General Scan Tool Instruction Manual.

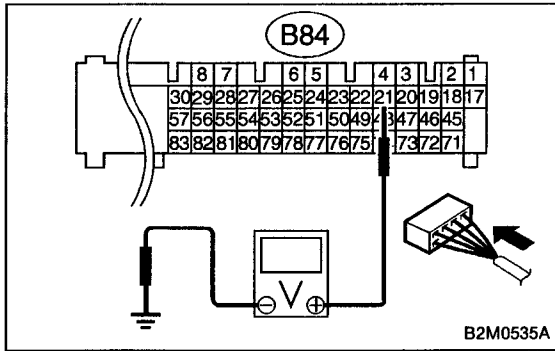

10BS2 **CHECK INPUT SIGNAL FOR ECM. (USING VOLTAGE METER AND SUBARU SELECT MONITOR.)**

1) Measure voltage between ECM connector and chassis ground.

CHECK : **Connector & terminal (B84) No. 21 (+) — Chassis ground (-): Is the voltage more than 4.5 V?**

YES : Go to next step 2).

NO : Go to next **CHECK** .

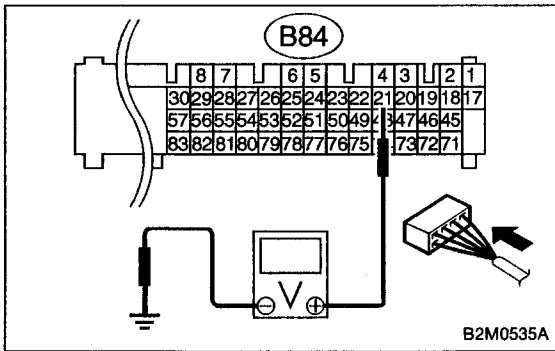

CHECK : **Does the voltage change more than 4.5 V by shaking harness and connector of ECM while monitoring the value with voltage meter?**

YES : Repair poor contact in ECM connector.

NO : Replace ECM.

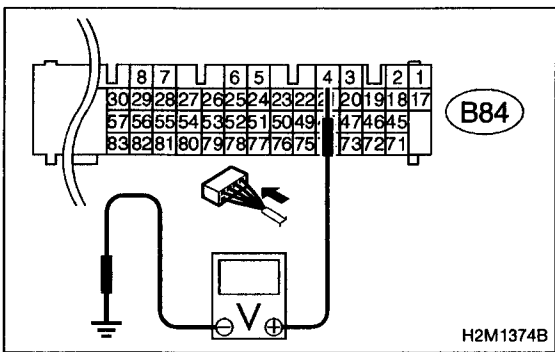

2) Measure voltage between ECM and chassis ground.

CHECK : **Connector & terminal (B84) No. 4 (+) — Chassis ground (-): Is the voltage less than 0.2 V?**

YES : Go to step **10BS3**.

NO : Go to next step 3).

TNKP (F43)
0.10kPa 1mmHg

H2M1326

3) Read data on Subaru Select Monitor.

- Subaru Select Monitor
- Designate mode using function key.

Function mode: F43

- F43: Display shows pressure signal value sent from fuel tank pressure sensor.

CHECK : Does the value change more than -2.8 kPa by shaking harness and connector of ECM while monitoring the value with Subaru select monitor?

YES : Repair poor contact in ECM connector.

NO : Go to step **10BS3**.

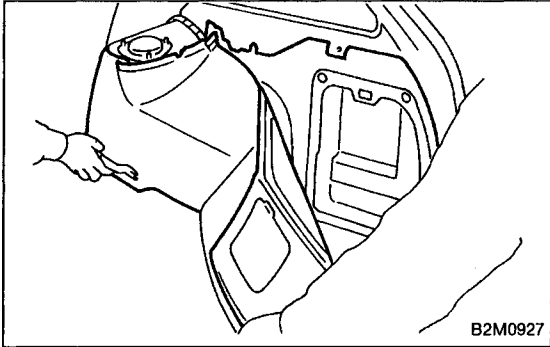
**10BS3****CHECK HARNESS BETWEEN ECM AND FUEL TANK PRESSURE SENSOR CONNECTOR.**

- 1) Turn ignition switch to OFF.
- 2) Detach right side rear quarter trim panel.
- 3) Remove right side rear quarter trim pocket.
- 4) Detach right side rear quarter insulator.

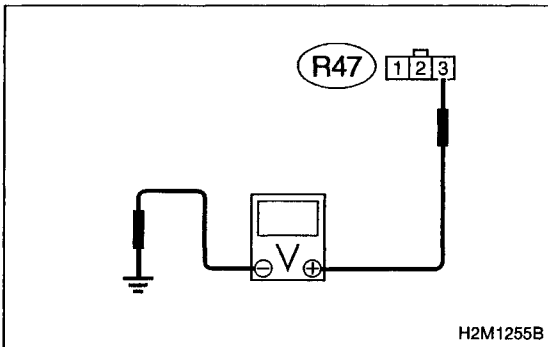

- 5) Disconnect connector from fuel tank pressure sensor.
- 6) Turn ignition switch to ON.
- 7) Measure voltage between fuel tank pressure sensor connector and chassis ground.

CHECK : **Connector & terminal (R47) No. 3 (+) — Chassis ground (-): Is the voltage more than 4.5 V?**

YES : Go to next step 8).

NO : Repair harness and connector.

NOTE:

In this case, repair the following:

- Open circuit in harness between ECM and fuel tank pressure sensor connector
- Poor contact in coupling connector (B97)

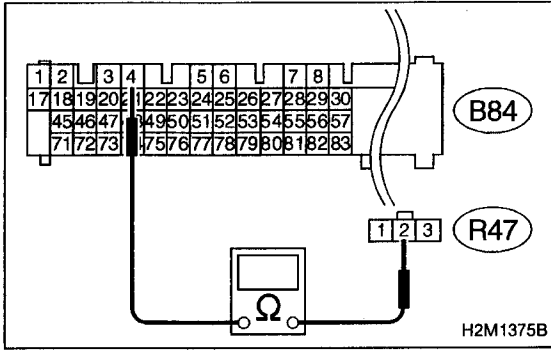

- 8) Turn ignition switch to OFF.
- 9) Disconnect connector from ECM.
- 10) Measure resistance of harness between ECM and pressure sensor connector.

CHECK : **Connector & terminal (B84) No. 4 — (R47) No. 2:**
Is the resistance less than 1 Ω?

YES : Go to next **CHECK** .

NO : Repair harness and connector.

NOTE:

In this case, repair the following:

- Open circuit in harness between ECM and fuel tank pressure sensor connector
- Poor contact in coupling connector (B97)

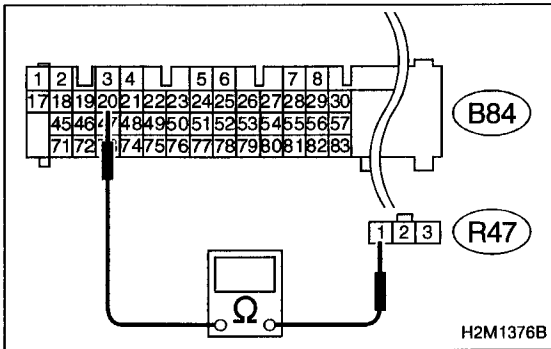

CHECK : **Connector & terminal (B84) No. 20 — (R47) No. 1:**
Is the resistance less than 1 Ω?

YES : Go to next step 11).

NO : Repair harness and connector.

NOTE:

In this case, repair the following:

- Open circuit in harness between ECM and fuel tank pressure sensor connector
- Poor contact in coupling connector (B97)

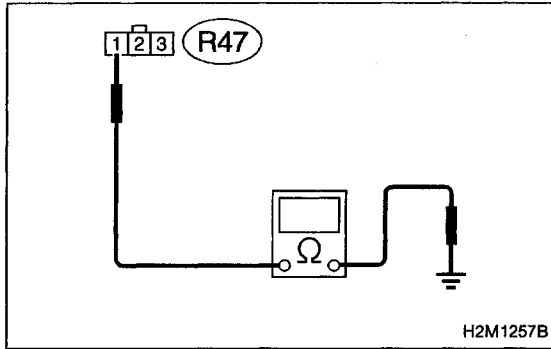

11) Measure resistance of harness between fuel tank pressure sensor connector and chassis ground.

CHECK : **Connector & terminal (R47) No. 1 — Chassis ground:**
Is the resistance more than 500 kΩ?

YES : Go to next **CHECK** .

NO : Repair short circuit in harness between ECM and fuel tank pressure sensor connector.

CHECK : **Is there poor contact in fuel tank pressure sensor connector?**

YES : Repair poor contact in fuel tank pressure sensor connector.

NO : Replace fuel tank pressure sensor.

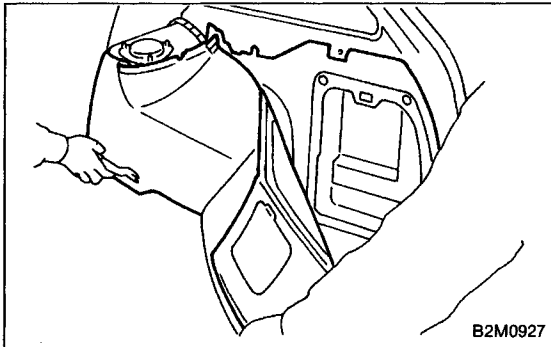

10BS4

CHECK HARNESS BETWEEN ECM AND FUEL TANK PRESSURE SENSOR CONNECTOR.

- 1) Turn ignition switch to OFF and Subaru Select Monitor or the OBD-II general scan tool switch to OFF.
- 2) Detach right side rear quarter trim panel.
- 3) Remove right side rear quarter trim pocket.
- 4) Detach right side rear quarter insulator.

TNKP	(F43)
0.10kPa	1mmHg

H2M1326

- 5) Disconnect connector from fuel tank pressure sensor.
- 6) Remove fuel filler cap.
- 7) Install fuel filler cap.
- 8) Turn ignition switch to ON and Subaru Select Monitor or the OBD-II general scan tool switch to ON.
- 9) Read data on Subaru select monitor or the OBD-II general scan tool.

- Subaru Select Monitor

Designate mode using function key.

Function mode: F43

CHECK : *Is the value more than 2.8 kPa in function mode F43?*

YES : Repair short circuit in harness between ECM and fuel tank pressure sensor connector.

NO : Replace fuel tank pressure sensor.

- OBD-II general scan tool

For detailed operation procedures, refer to the OBD-II General Scan Tool Instruction Manual.

OBD (FB1)
 P0451 <TNKP_F>

H2M1377

BT: DTC P0451
— EVAPORATIVE EMISSION CONTROL SYSTEM PRESSURE SENSOR RANGE/PERFORMANCE PROBLEM (TNKP — F) —

DTC DETECTING CONDITION:

- Two consecutive trips with fault

10BT1	Check pressure/vacuum line.
-------	-----------------------------

CAUTION:

After repair or replacement of faulty parts, conduct CLEAR MEMORY and INSPECTION MODES.

< Ref. to 2-7 [T3D0] and [T3E0]. ☆2 and ☆4 >

WIRING DIAGRAM:

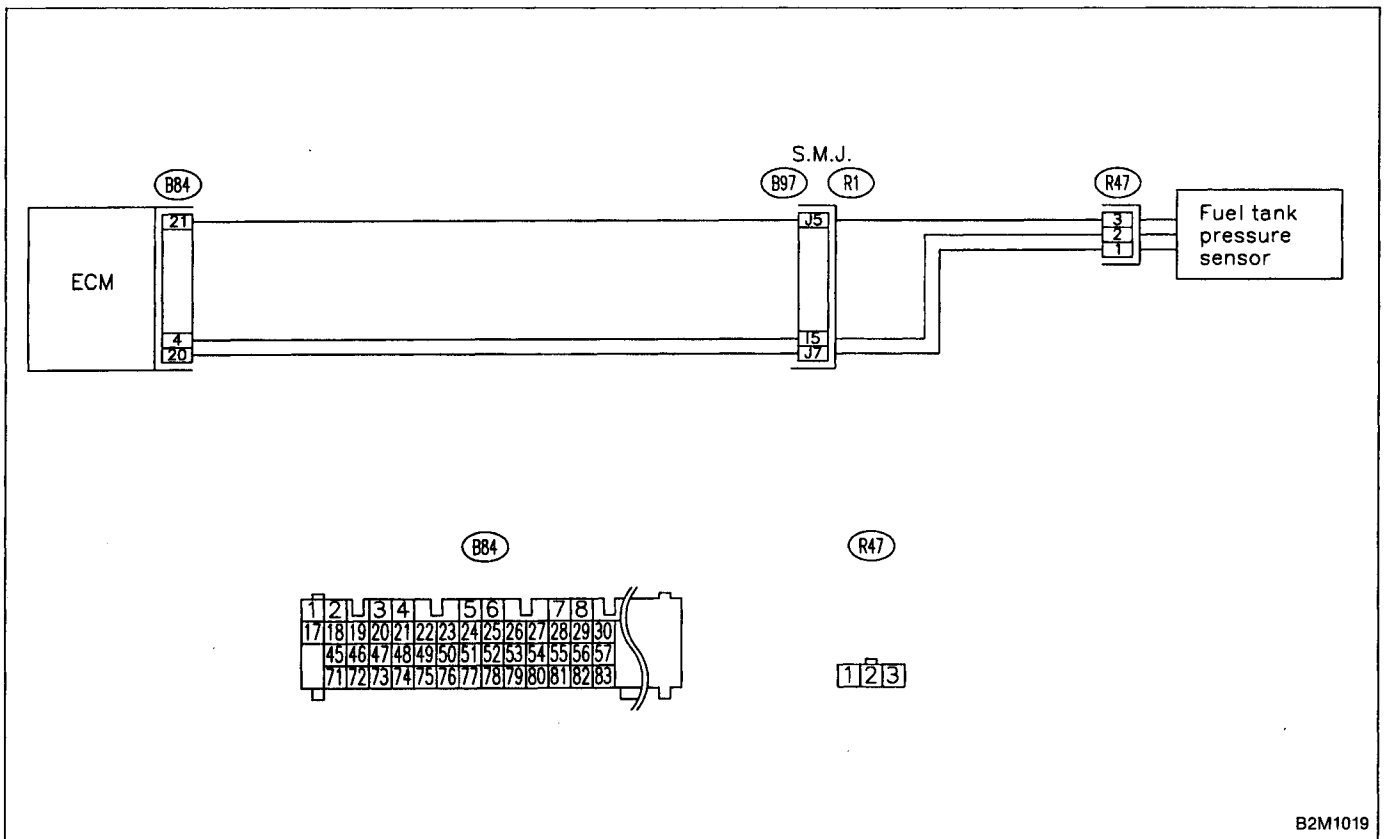

10BT1	CHECK PRESSURE/VACUUM LINE.
--------------	------------------------------------

CHECK : *Is there a fault in pressure/vacuum line?*

NOTE:

Check the following items.

- Disconnection, leakage and clogging of the vacuum hoses and pipes between fuel tank pressure sensor and fuel tank
- Disconnection, leakage and clogging of air ventilation hoses and pipes between fuel filler pipe and fuel tank

YES : Repair or replace hoses and pipes.

NO : Replace fuel tank pressure sensor.

<p>OBD (FB1) P1400 <PCVSOL></p> <p style="text-align: right; font-size: small;">H2M1406</p>

BU: DTC P1400
— FUEL TANK PRESSURE CONTROL SOLENOID VALVE CIRCUIT MALFUNCTION (PCVSOL) —

DTC DETECTING CONDITION:
● Two consecutive trips with fault

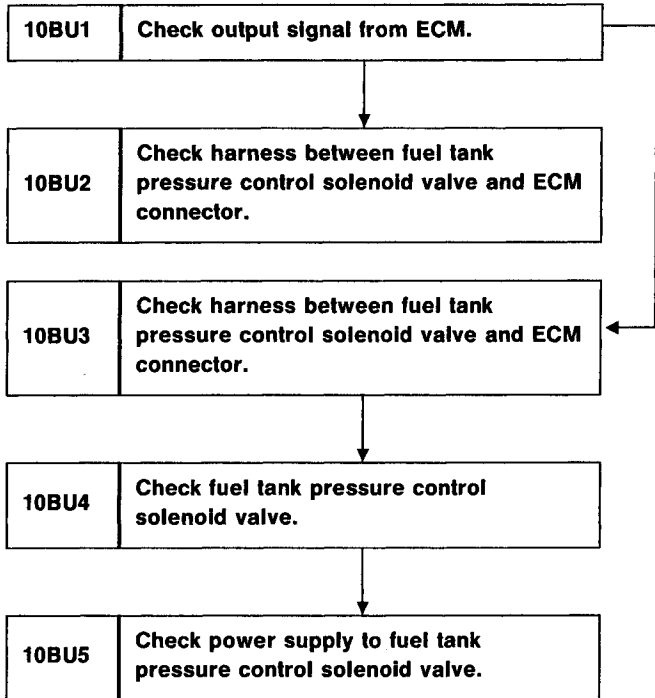

CAUTION:
After repair or replacement of faulty parts, conduct CLEAR MEMORY and INSPECTION MODES.
< Ref. to 2-7 [T3D0] and [T3E0].☆2 and ☆4 >

WIRING DIAGRAM:

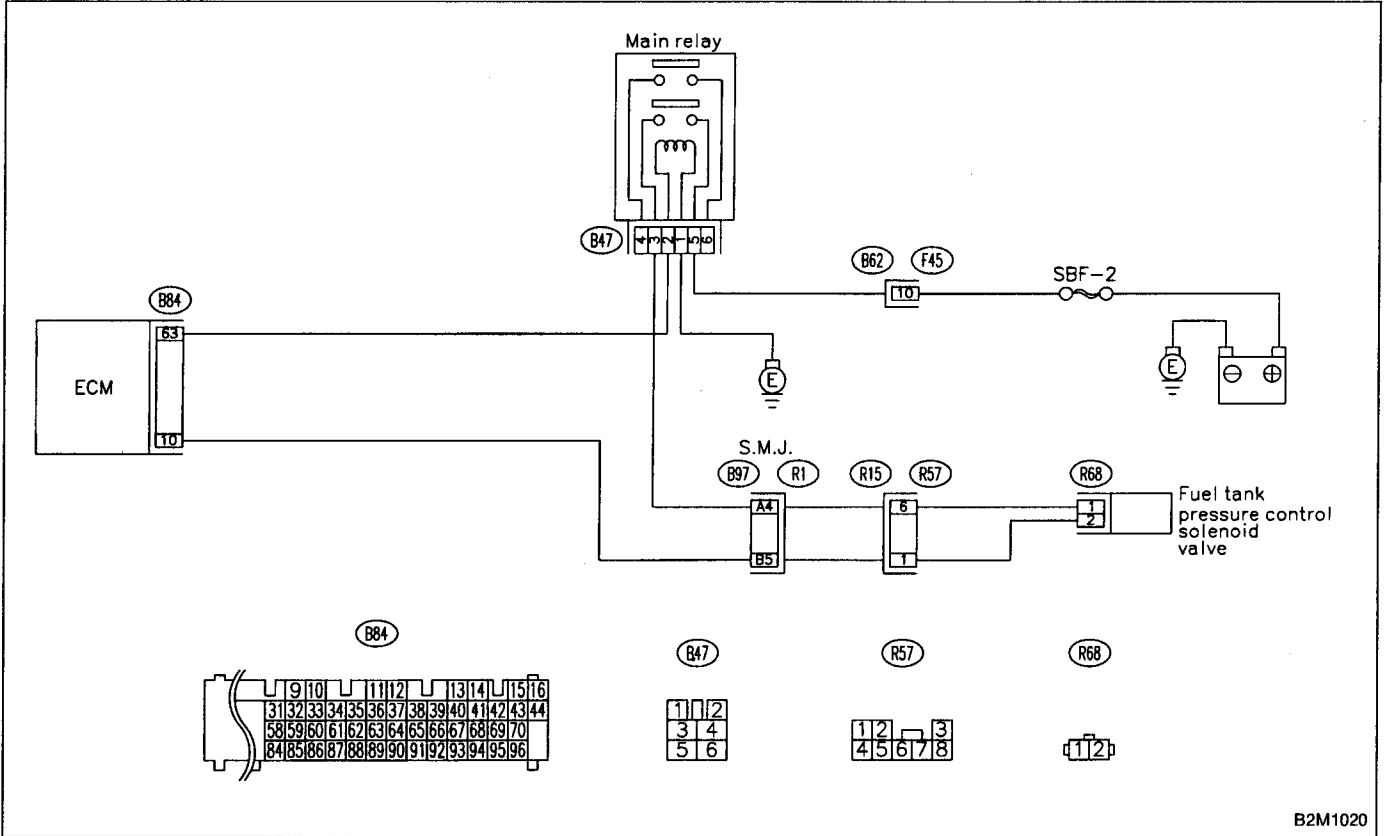

B2M1020

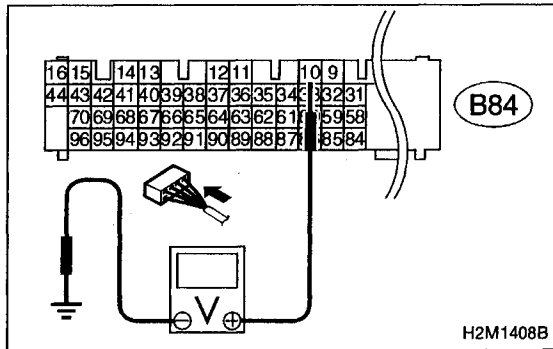

10BU1 CHECK OUTPUT SIGNAL FROM ECM.

- 1) Turn ignition switch to ON.
- 2) Measure voltage between ECM and chassis ground.

CHECK : **Connector & terminal (B84) No. 10 (+) — Chassis ground (-): Is the voltage more than 10 V?**

YES : Go to step **10BU2**.

NO : Go to step **10BU3**.

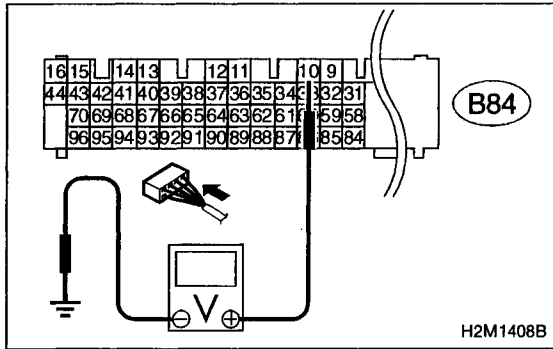

10BU2 CHECK HARNESS BETWEEN FUEL TANK PRESSURE CONTROL SOLENOID VALVE AND ECM CONNECTOR.

- 1) Turn ignition switch to OFF.
- 2) Disconnect connector from fuel tank pressure control solenoid valve.
- 3) Turn ignition switch to ON.
- 4) Measure voltage between ECM and chassis ground.

CHECK : **Connector & terminal (B84) No. 10 (+) — Chassis ground (-): Is the voltage more than 10 V?**

YES : Repair short circuit in harness and replace ECM.

NOTE:

The harness between ECM and fuel tank pressure control solenoid valve is in short circuit.

NO : Go to next step 5).

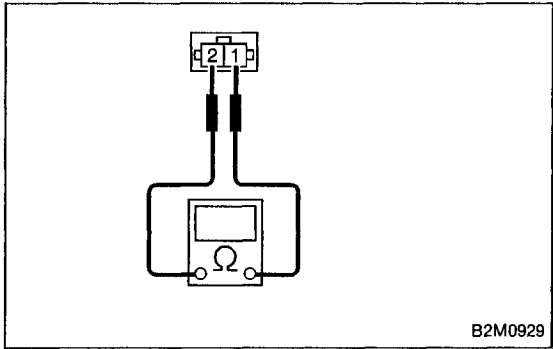

- 5) Turn ignition switch to OFF.
- 6) Measure resistance between fuel tank pressure control solenoid valve terminals.

CHECK : **Terminals No. 1 — No. 2: Is the resistance less than 1 Ω?**

YES : Replace fuel tank pressure control solenoid valve and ECM.

NO : Go to next **CHECK** .

CHECK : **Is there poor contact in ECM connector?**

YES : Repair poor contact in ECM connector.

NO : Replace ECM.

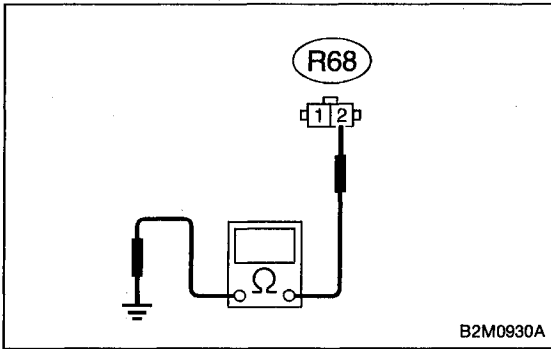

10BU3 CHECK HARNESS BETWEEN FUEL TANK PRESSURE CONTROL SOLENOID VALVE AND ECM CONNECTOR.

- 1) Turn ignition switch to OFF.
- 2) Disconnect connectors from fuel tank pressure control solenoid valve and ECM.
- 3) Measure resistance of harness between fuel tank pressure control solenoid valve connector and chassis ground.

CHECK : *Connector & terminal (R68) No. 2 — Chassis ground: Is the resistance less than 10 Ω?*

YES : Repair short circuit in harness between ECM and fuel tank pressure control solenoid valve connector.

NO : Go to next step 4).

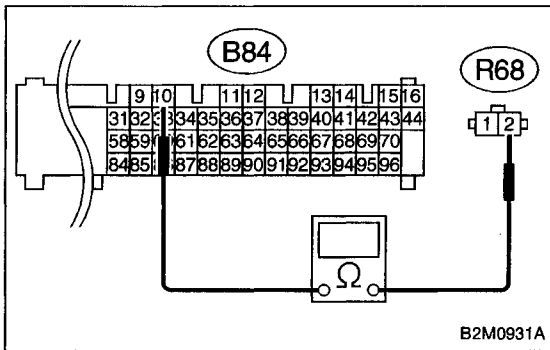

- 4) Measure resistance of harness between ECM and fuel tank pressure control solenoid valve connector.

CHECK : *Connector & terminal (B84) No. 10 — (R68) No. 2: Is the voltage less than 1 Ω?*

YES : Go to step 10BU4.

NO : Repair harness and connector.

NOTE:

In this case, repair the following:

- Open circuit in harness between ECM and fuel tank pressure control solenoid valve connector
- Poor contact in coupling connectors (B97 and R57)

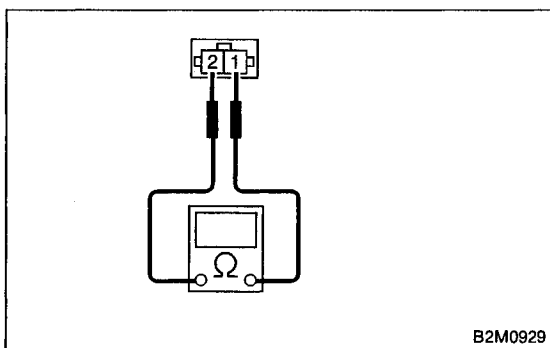

10BU4 CHECK FUEL TANK PRESSURE CONTROL SOLENOID VALVE.

Measure resistance between fuel tank pressure control solenoid valve terminals.

CHECK : *Terminals No. 1 — No. 2: Is the resistance between 10 and 100 Ω?*

YES : Go to step 10BU5.

NO : Replace fuel tank pressure control solenoid valve.

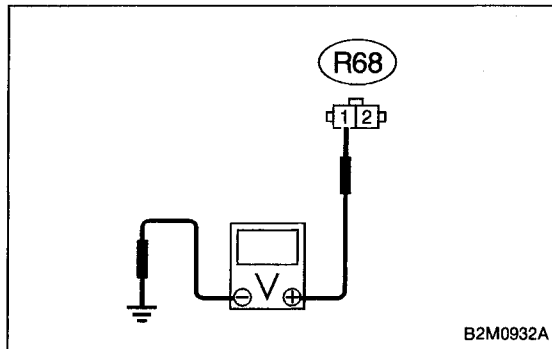
**10BU5****CHECK POWER SUPPLY TO FUEL TANK PRESSURE CONTROL SOLENOID VALVE.**

- 1) Turn ignition switch to ON.
- 2) Measure voltage between fuel tank pressure control solenoid valve and chassis ground.

CHECK : **Connector & terminal (R68) No. 1 (+) — Chassis ground (-): Is the voltage more than 10 V?**

YES : Go to next **CHECK** .

NO : Repair harness and connector.

NOTE:

In this case, repair the following:

- Open circuit in harness between main relay and fuel tank pressure control solenoid valve connector
- Poor contact in coupling connectors (B97 and R57)
- Poor contact in main relay connector

CHECK : **Is there poor contact in fuel tank pressure control solenoid valve connector?**

YES : Repair poor contact in fuel tank pressure control solenoid valve connector.

NO : Contact with SOA service.

NOTE:

Inspection by DTM is required, because probable cause is deterioration of multiple parts.

OBD (FB1)
 P1401 <PCV_F>
 H2M1410

BV: DTC P1401
— FUEL TANK PRESSURE CONTROL SYSTEM
FUNCTION PROBLEM (PCV — F) —

DTC DETECTING CONDITION:

- Two consecutive trips with fault

10BV1	Check fuel tank pressure control solenoid valve.
-------	--

CAUTION:

After repair or replacement of faulty parts, conduct CLEAR MEMORY and INSPECTION MODES.

< Ref. to 2-7 [T3D0] and [T3E0].☆2 and ☆4 >

WIRING DIAGRAM:

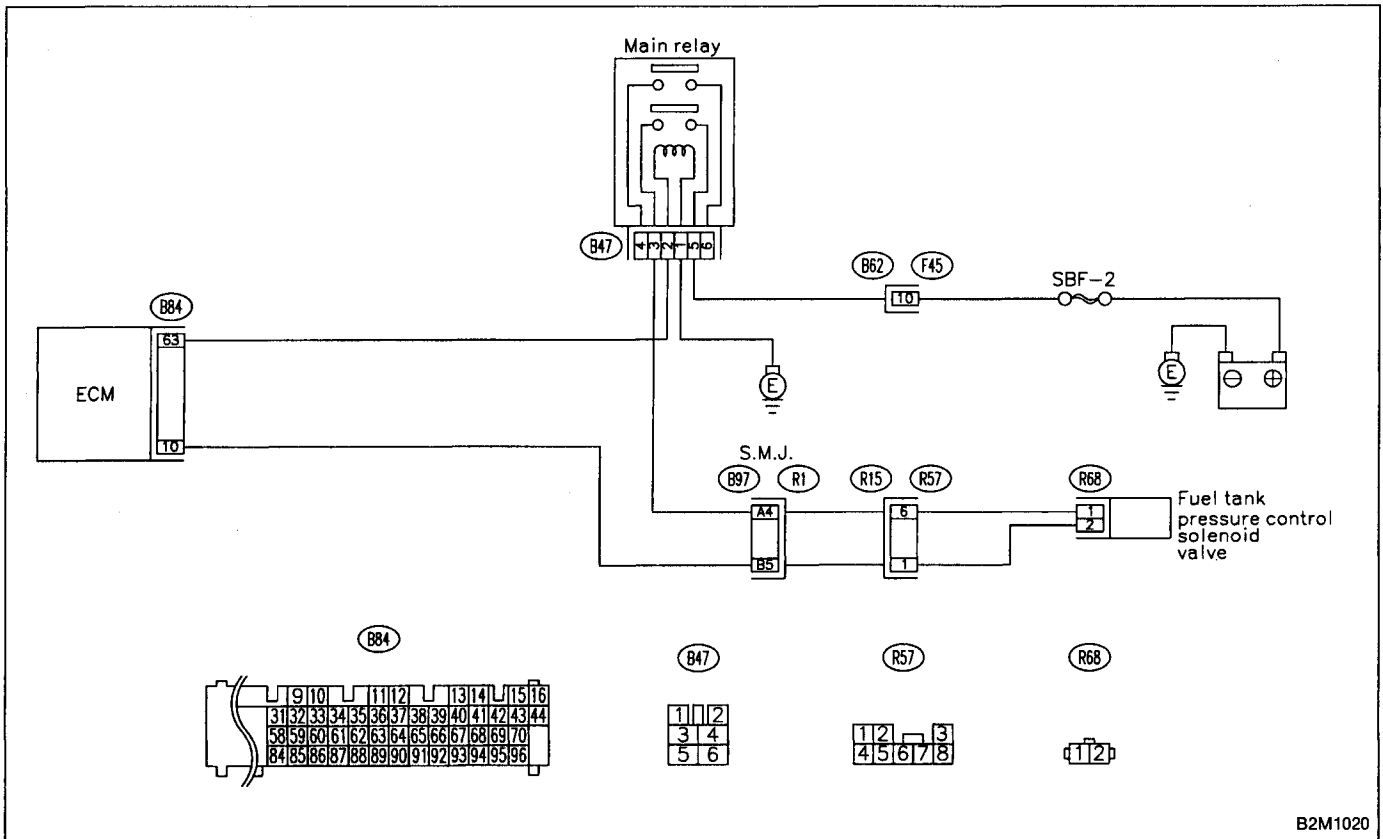

B2M1020

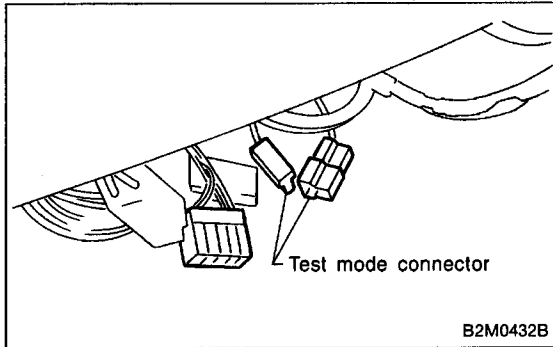
**10BV1 CHECK FUEL TANK PRESSURE CONTROL SOLENOID VALVE.**

- 1) Turn ignition switch to OFF.
- 2) Connect test mode connector.
- 3) Turn ignition switch to ON.

CHECK : **Does fuel tank pressure control solenoid valve produce operating sound?**

NOTE:

Fuel tank pressure control solenoid valve operation check can also be executed using Subaru Select Monitor (Function mode: FD07). For the procedure, refer to "COMPULSORY VALVE OPERATION CHECK MODE" 2-7 [T3F0]☆4.

YES : Check evaporative emission control system.
<Ref. to 2-7 [T10BQ0].☆7 >

NO : Replace fuel tank pressure control solenoid valve.

OBD P1402	(FB1) <FLVL>
H2M1411	

BW: DTC P1402
— FUEL LEVEL SENSOR CIRCUIT
MALFUNCTION (FLVL) —

DTC DETECTING CONDITION:

- Two consecutive trips with fault

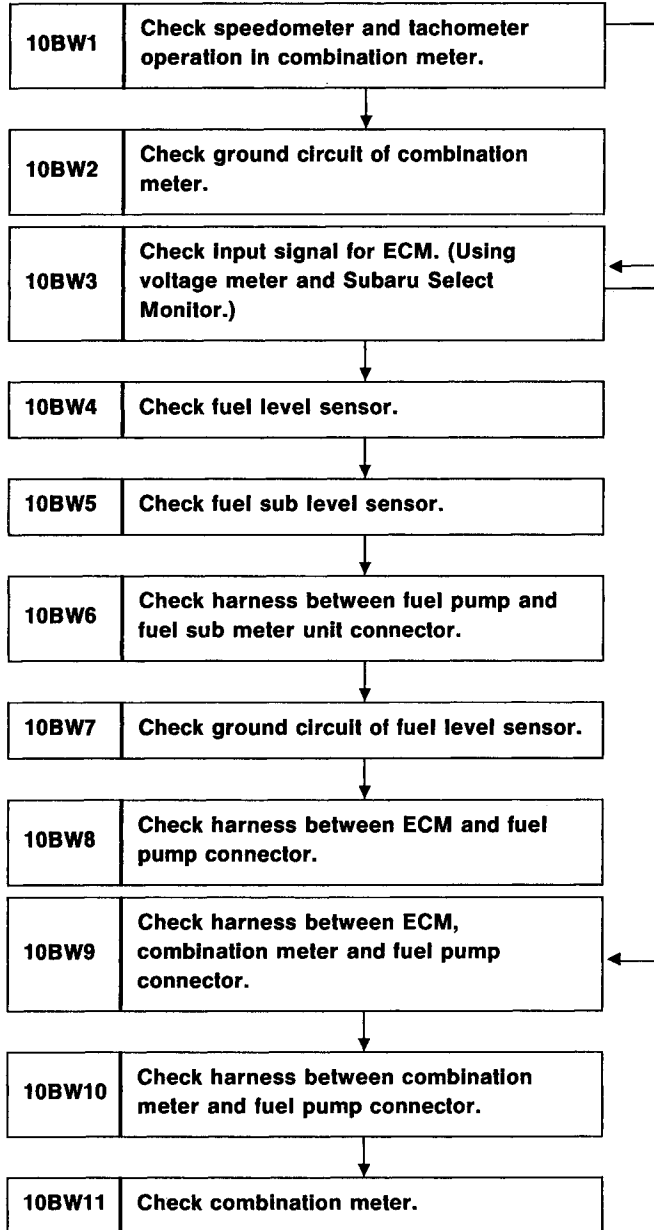

CAUTION:

After repair or replacement of faulty parts, conduct CLEAR MEMORY and INSPECTION MODES.

< Ref. to 2-7 [T3D0] and [T3E0].☆2 and ☆4 >

WIRING DIAGRAM:

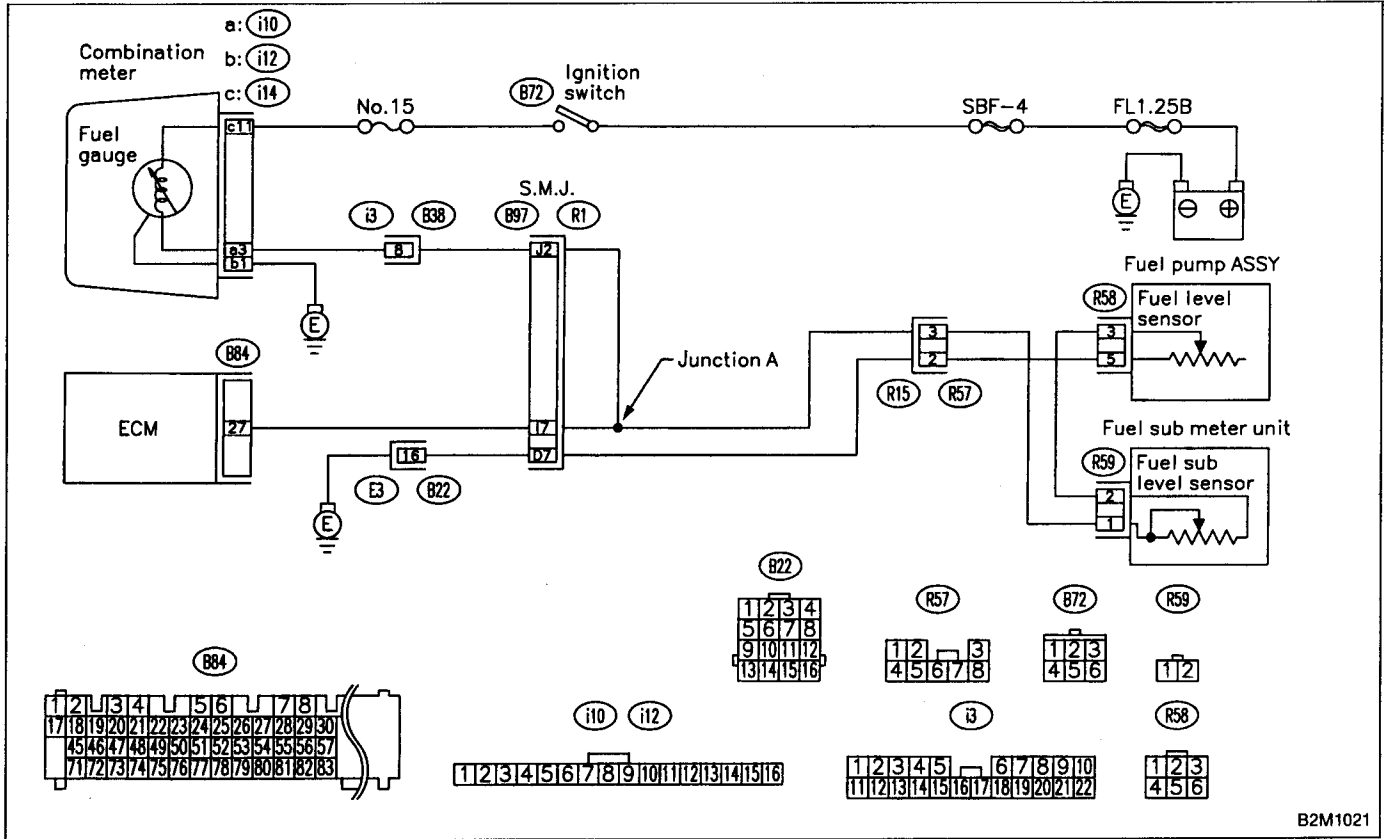

B2M1021

10BW1 CHECK SPEEDOMETER AND TACHOMETER OPERATION IN COMBINATION METER.

CHECK : Does speedometer and tachometer operate normally?

YES : Go to step 10BW3.

NO : Go to step 10BW2.

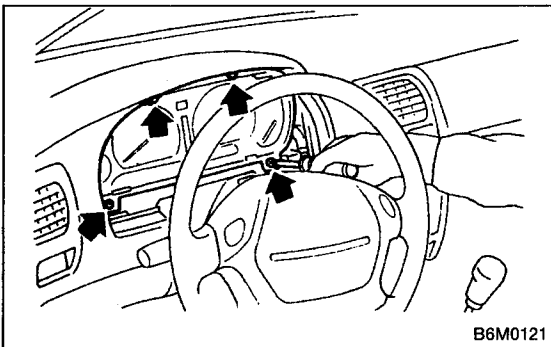

B6M0121

10BW2 CHECK GROUND CIRCUIT OF COMBINATION METER.

- 1) Turn ignition switch to OFF.
- 2) Pull out combination meter from instrument panel. <Ref. to 6-2 [W13A1].☆1 >
- 3) Disconnect connector from combination meter.

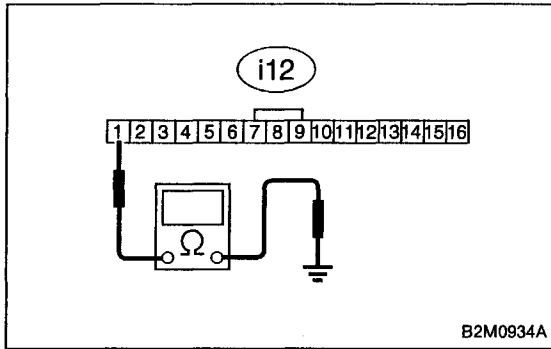

4) Measure resistance of harness between combination meter connector and chassis ground.

CHECK : **Connector & terminal (i12) No. 1 — Chassis ground: Is resistance less than 5 Ω?**

YES : Repair or replace combination meter.

NO : Repair harness and connector.

NOTE:

In this case, repair the following:

- Open circuit in harness between combination meter connector and grounding terminal
- Poor contact in combination meter connector
- Poor contact in grounding terminal

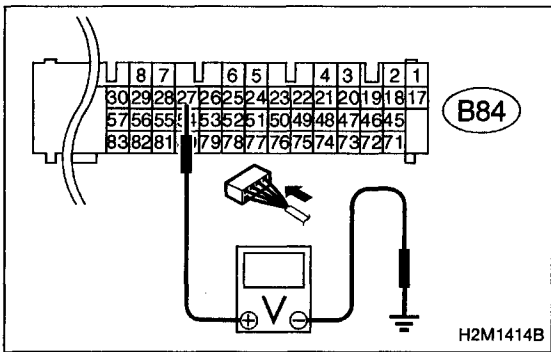

10BW3 CHECK INPUT SIGNAL FOR ECM. (USING VOLTAGE METER AND SUBARU SELECT MONITOR.)

1) Turn ignition switch to ON. (Engine OFF)
2) Measure voltage between ECM connector and chassis ground.

CHECK : **Connector & terminal (B84) No. 27 (+) — Chassis ground (-): Is the voltage more than 4.75 V?**

YES : Go to step **10BW4**.

NO : Go to next step 3).

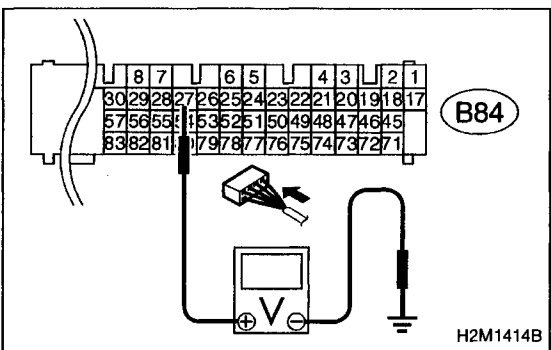

3) Measure voltage between ECM connector and chassis ground.

CHECK : **Connector & terminal (B84) No. 27 (+) — Chassis ground (-): Is the voltage less than 0.12 V?**

YES : Go to step **10BW9**.

NO : Go to next **CHECK** .

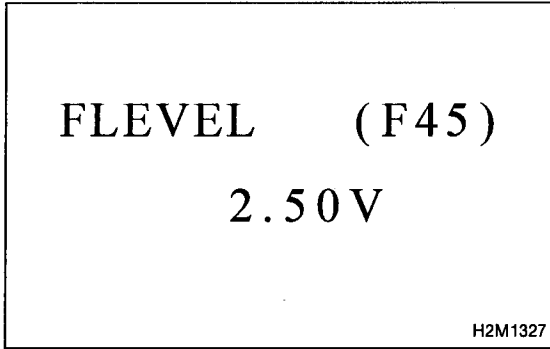

CHECK : Does the value change less than 0.12 V by shaking harness and connector of ECM while monitoring the value with Subaru Select Monitor?

- Subaru Select Monitor
Designate mode using function key.

Function mode: F45

- F45: Fuel level sensor output signal is indicated.

YES : Repair poor contact in ECM connector.

NO : Even if MIL lights up, the circuit has returned to a normal condition at this time. A temporary poor contact of the connector may be the cause.

NOTE:

In this case, repair the following:

- Poor contact in fuel pump connector
- Poor contact in combination meter connector
- Poor contact in ECM connector
- Poor contact in coupling connector (i3, B22, B97 and R57)

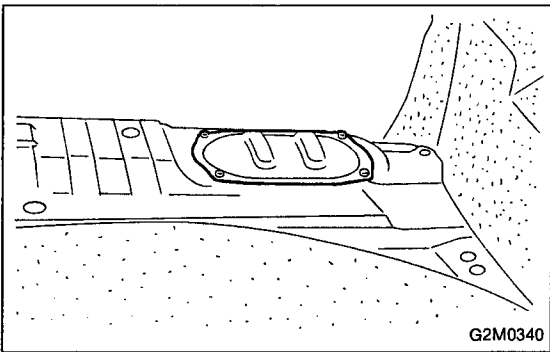

10BW4 CHECK FUEL LEVEL SENSOR.

- 1) Turn ignition switch to OFF.
- 2) Remove fuel pump access hole lid located on the right rear of luggage compartment floor.

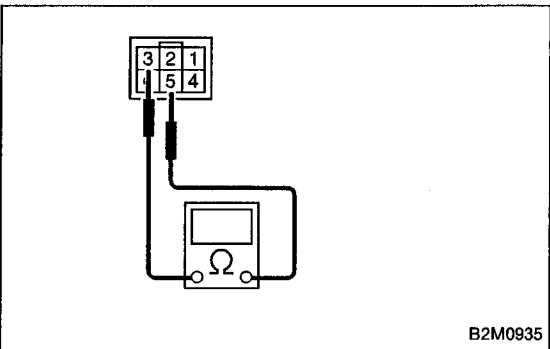

- 3) Disconnect connector from fuel pump.
- 4) Measure resistance between connector terminals of fuel pump.

CHECK : **Terminals No. 3 — No. 5:**
Is the resistance less than 100 Ω?

YES : Go to step **10BW5**.

NO : Replace fuel sending unit.

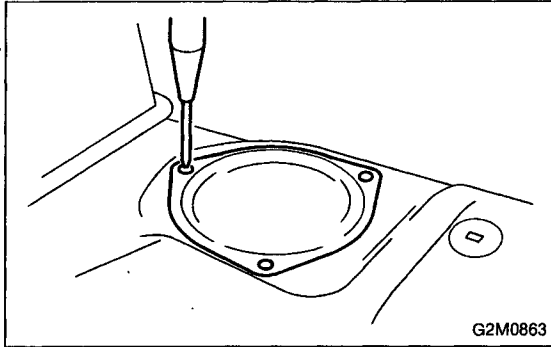

G2M0863

10BW5 CHECK FUEL SUB LEVEL SENSOR.

1) Remove service hole cover located on the left rear of luggage compartment floor.

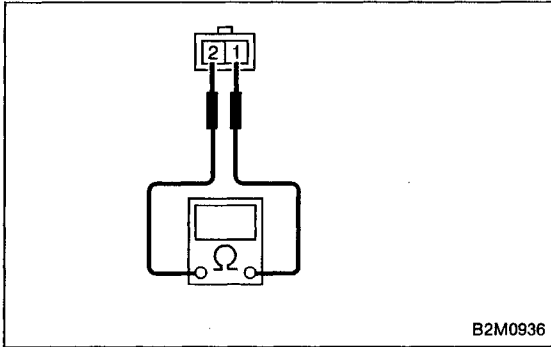

B2M0936

2) Disconnect connector from fuel sub meter unit.
3) Measure resistance between connector terminals of fuel sub meter unit.

CHECK : **Terminals**
No. 1 — No. 2:
Is the resistance less than 100 Ω?

YES : Go to step **10BW6**.

NO : Replace fuel sub meter unit.

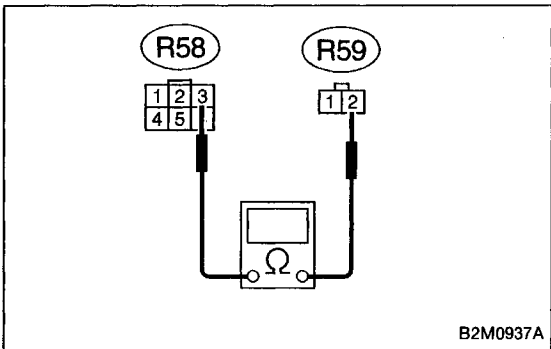

B2M0937A

10BW6 CHECK HARNESS BETWEEN FUEL PUMP AND FUEL SUB METER UNIT CONNECTOR.

Measure resistance of harness between fuel pump and fuel sub meter unit connector.

CHECK : **Connector & terminal**
(R58) No. 3 — (R59) No. 2:
Is the resistance less than 1 Ω?

YES : Go to step **10BW7**.

NO : Repair open circuit in harness between fuel pump and fuel sub meter unit connector.

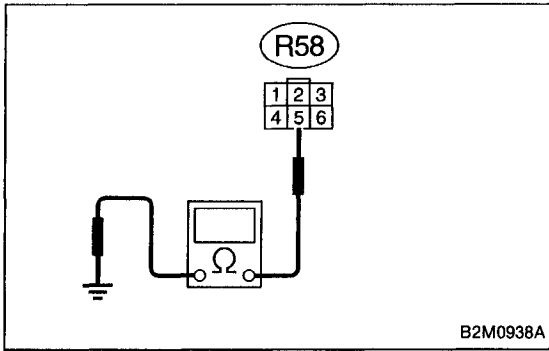

10BW7 CHECK GROUND CIRCUIT OF FUEL LEVEL SENSOR.

Measure resistance of harness between fuel pump connector and chassis ground.

CHECK : **Connector & terminal (R58) No. 5 — Chassis ground: Is the resistance less than 5 Ω?**

YES : Go to step **10BW8**.

NO : Repair harness and connector.

NOTE:

In this case, repair the following:

- Open circuit in harness between fuel pump connector and chassis grounding terminal
- Poor contact in fuel pump connector
- Poor contact in coupling connectors (R57, B97 and B22)

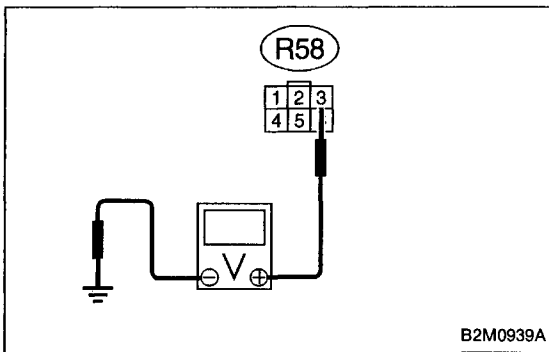

10BW8 CHECK HARNESS BETWEEN ECM AND FUEL PUMP CONNECTOR.

- 1) Connect connector to fuel sub meter unit.
- 2) Turn ignition switch to ON.
- 3) Measure voltage between fuel pump connector and chassis ground.

CHECK : **Connector & terminal (R58) No. 3 (+) — Chassis ground (-): Is the voltage less than 1 V?**

YES : Repair harness and connector.

NOTE:

In this case, repair the following:

- Open circuit in harness between fuel pump connector and junction A on rear wiring harness
- Poor contact in fuel sub meter unit connector
- Poor contact in fuel pump connector
- Poor contact in coupling connector (R57)

NO : Go to next step 4).

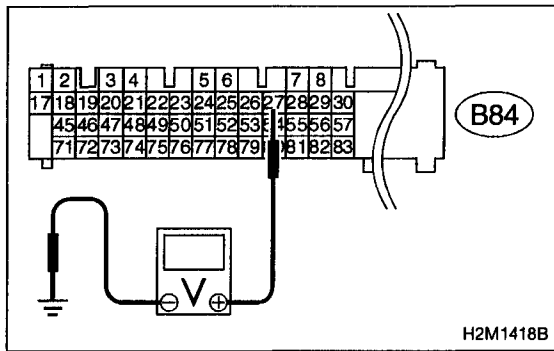

- 4) Turn ignition switch to OFF.
- 5) Disconnect connector from ECM.
- 6) Turn ignition switch to ON.
- 7) Measure voltage between ECM connector and chassis ground.

CHECK : Connector & terminal (B84) No. 27 (+) — Chassis ground: Is the voltage less than 1 V?

YES : Repair harness and connector.

NOTE:

In this case, repair the following:

- Open circuit in harness between ECM connector and junction A on rear wiring harness
- Poor contact in coupling connector (B97)

NO : Repair connector.

NOTE:

In this case, repair the following:

- Poor contact in fuel pump connector
- Poor contact in fuel sub meter unit
- Poor contact in ECM connector

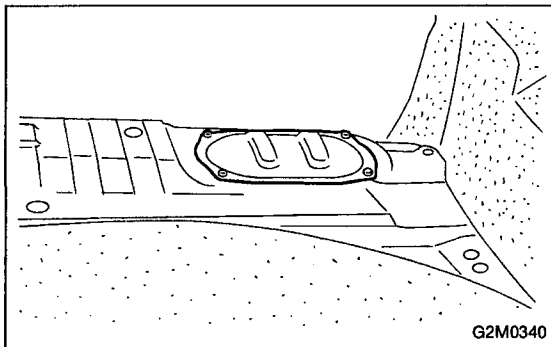

10BW9	CHECK HARNESS BETWEEN ECM, COMBINATION METER AND FUEL PUMP CONNECTOR.
--------------	--

- 1) Turn ignition switch to OFF.
- 2) Remove fuel pump access hole lid located on the right rear of luggage compartment floor.

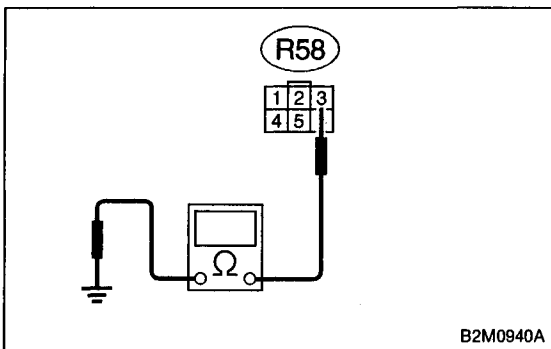

- 3) Disconnect connector from fuel pump.
- 4) Measure resistance of harness between fuel pump connector and chassis ground.

CHECK : Connector & terminal (R58) No. 3 — Chassis ground: Is the resistance less than 10 Ω?

YES : Go to next step 5).

NO : Go to step **10BW10**.

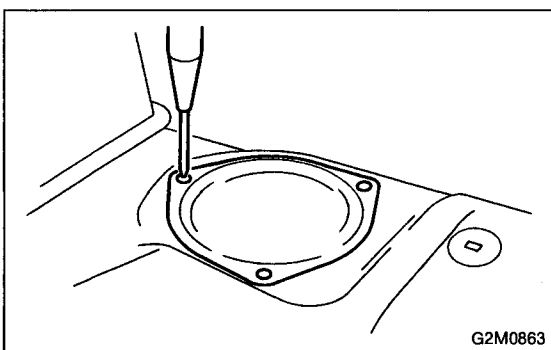

- 5) Remove service hole cover located on the left rear of luggage compartment floor.

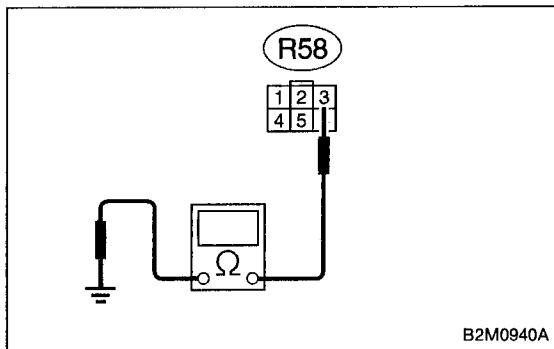

- 6) Disconnect connector from fuel sub meter unit.
- 7) Measure resistance of harness between fuel pump connector and chassis ground.

CHECK : **Connector & terminal (R58) No. 3 — Chassis ground: Is the resistance less than 10 Ω?**

YES : Repair short circuit in harness between fuel pump and fuel sub meter unit connector.

NO : Go to next step 8).

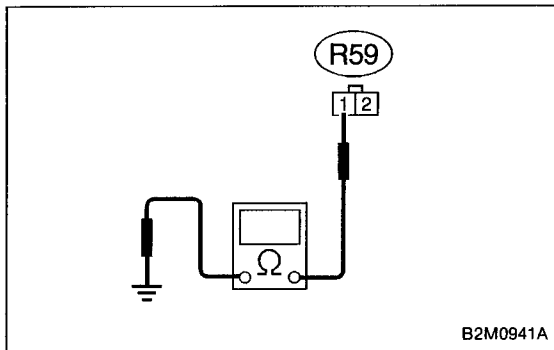

- 8) Separate fuel tank cord connector (R57) and rear wiring harness connector (R15).
- 9) Measure resistance of harness between fuel sub meter unit connector and chassis ground.

CHECK : **Connector & terminal (R59) No. 1 — Chassis ground: Is the resistance less than 10 Ω?**

YES : Repair short circuit in fuel tank cord.

NO : Go to next step 10).

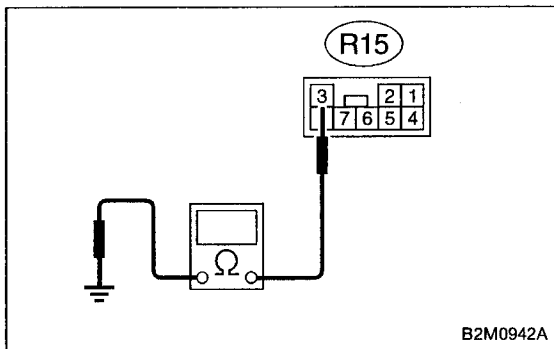

- 10) Separate rear wiring harness connector (R1) and bulkhead wiring harness connector (B97).
- 11) Measure resistance of harness between rear wiring harness connector and chassis ground.

CHECK : **Connector & terminal (R15) No. 3 — Chassis ground: Is the resistance less than 10 Ω?**

YES : Repair short circuit in rear wiring harness.

NO : Go to next step 12).

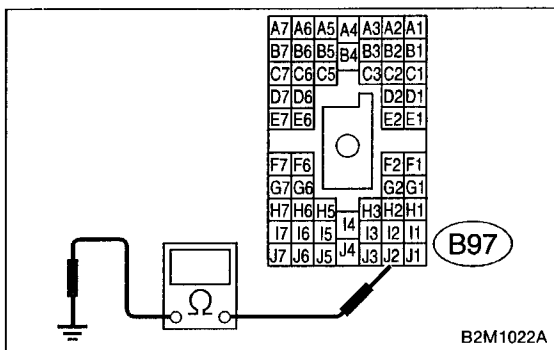

- 12) Measure resistance of harness between bulkhead wiring connector and chassis ground.

CHECK : **Connector & terminal (B97) No. J2 — Chassis ground: Is the resistance less than 10 Ω?**

YES : Go to next step 13).

NO : Repair short circuit in harness between S.M.J. and ECM connector.

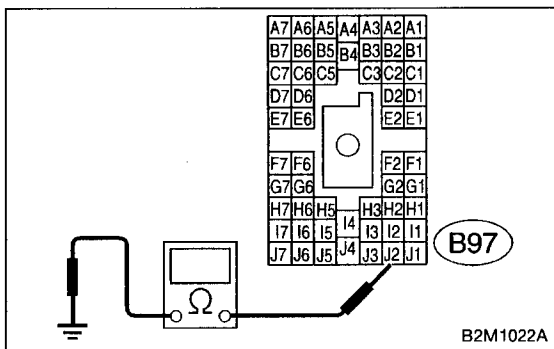

- 13) Separate bulkhead wiring harness connector (B38) and instrument panel wiring harness connector (i3).
- 14) Measure resistance of harness between bulkhead wiring harness connector and chassis ground.

CHECK : **Connector & terminal (B97) No. J2 — Chassis ground: Is the resistance less than 10 Ω?**

YES : Repair short circuit in bulkhead wiring harness.

NO : Repair short circuit in instrument panel wiring harness.

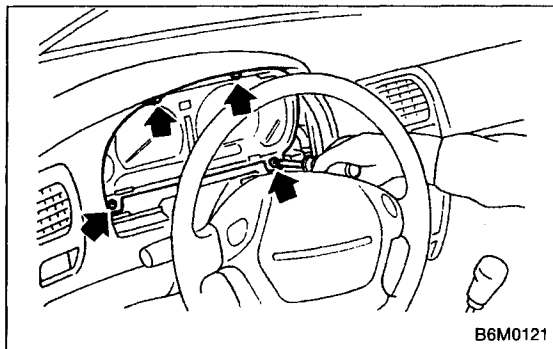

10BW10	CHECK HARNESS BETWEEN COMBINATION METER AND FUEL PUMP CONNECTOR.
---------------	---

- 1) Connect connector to fuel pump.
- 2) Pull out combination meter from instrument panel.
<Ref. to 6-2 [W13A1].☆1 >
- 3) Disconnect connector from combination meter.

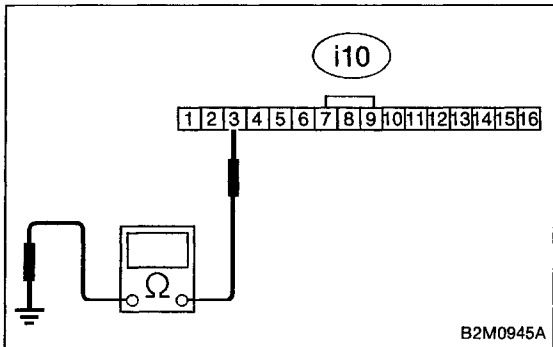

- 4) Measure resistance of harness between combination meter connector and chassis ground.

CHECK : **Connector & terminal (i10) No. 3 — Chassis ground:**
Is the resistance less than 200 Ω?

YES : Go to step **10BW11**.

NO : Repair harness and connector.

NOTE:

In this case, repair the following:

- Open circuit in harness between combination meter connector and junction A on rear wiring harness
- Poor contact in coupling connectors (i3 and B97)

10BW11	CHECK COMBINATION METER.
---------------	---------------------------------

- 1) Disconnect speedometer cable from combination meter and remove combination meter.

CHECK : **Is the fuel meter installation screw tightened securely?**

YES : Go to next step 2).

NO : Tighten fuel meter installation screw securely.

- 2) Remove printed circuit plate assembly from combination meter assembly.

CHECK : **Is there flaw or burning on printed circuit plate assembly?**

YES : Replace printed circuit plate assembly.

NO : Replace fuel meter assembly.

OBD (FB1)

EXERR22

B2M0947

BX: DTC P0461
— FUEL LEVEL SENSOR CIRCUIT RANGE/ PERFORMANCE PROBLEM (EXERR22) —

DTC DETECTING CONDITION:

- Two consecutive trips with fault

10BX1	Check DTC P1402 on display.
--------------	-----------------------------

CAUTION:

After repair or replacement of faulty parts, conduct **CLEAR MEMORY** and **INSPECTION MODES**.

< Ref. to 2-7 [T3D0] and [T3E0]. ☆2 and ☆4 >

WIRING DIAGRAM:

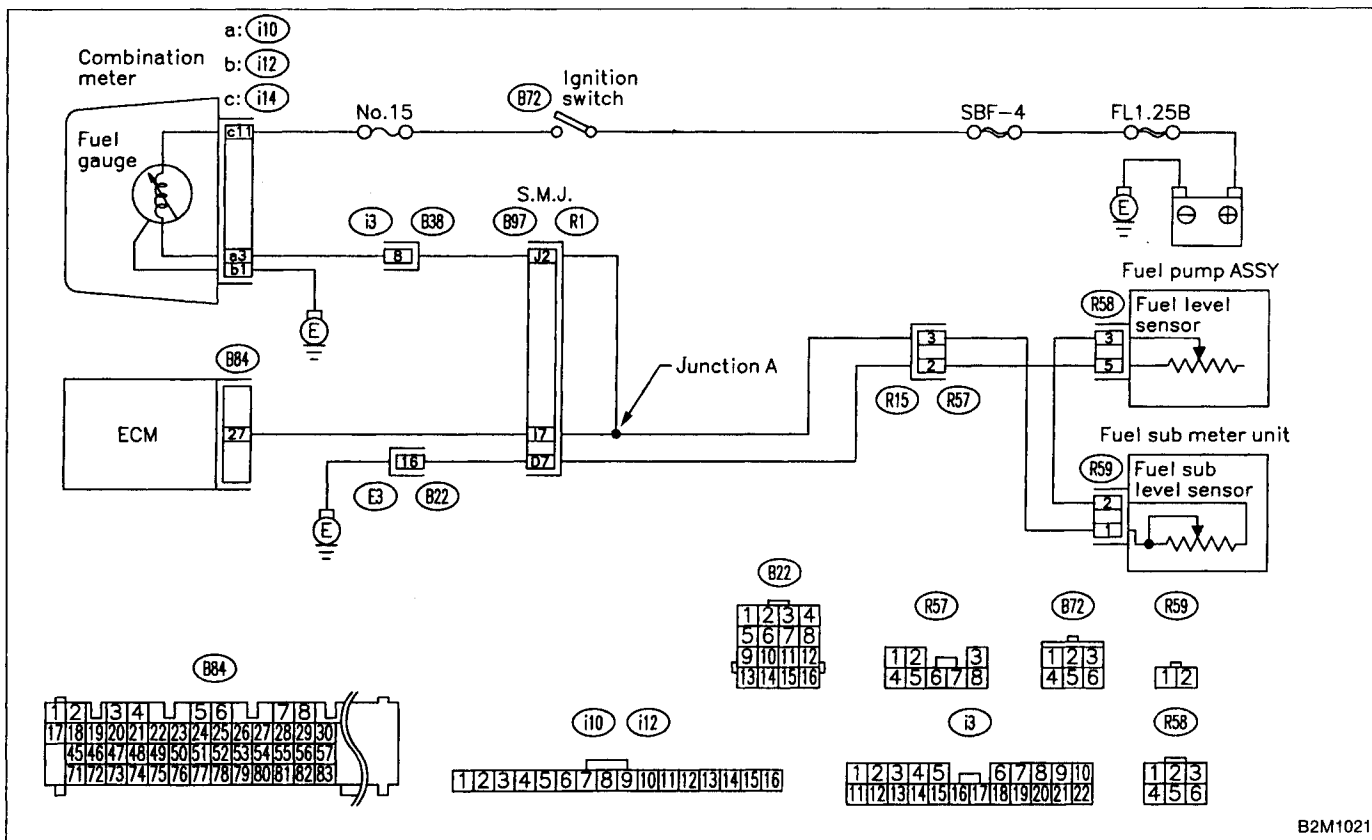

B2M1021

10BX1	CHECK DTC P1402 ON DISPLAY.
--------------	------------------------------------

CHECK : *Does the Subaru select monitor or OBD-II general scan tool indicate DTC P1402?*

YES : Inspect DTC P1402 using "10. Diagnostics Chart with Trouble Code 2-7 [T10A0]"☆7.

NOTE:

In this case, it is not necessary to inspect this trouble.

NO : Replace fuel sending unit and fuel sub meter unit.