

3. Rear Gate

A: REMOVAL AND INSTALLATION

CAUTION:

- Be careful not to scratch coated surfaces of vehicle body and window glass during removal. Place a cloth over the affected area.
- Be careful not to damage trim panels.
- Use an assistant when handling heavy parts.
- Be careful not to damage or lose small parts.

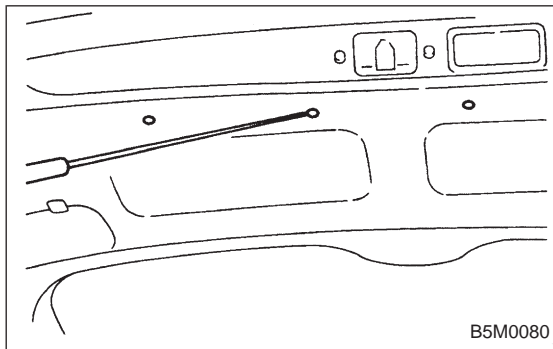

1. REAR GATE ASSEMBLY

- 1) Remove clips from trim panel and detach trim panel.

CAUTION:

Be careful not to damage clips or their holes.

- 2) Disconnect connectors and terminal.
- 3) Disconnect rear washer hose from wiper motor.
- 4) Remove high-mount stop light.

- 5) If disconnected harness is re-used, tie connector with a string and place on the upper side of rear gate for ready use.

CAUTION:

Do not forcefully pull cords, lead wires, etc. since damage may result; carefully extract them in a wavy motion while holding connectors.

- 6) Remove both rubber ducts and then extract washer hose and harness connector.

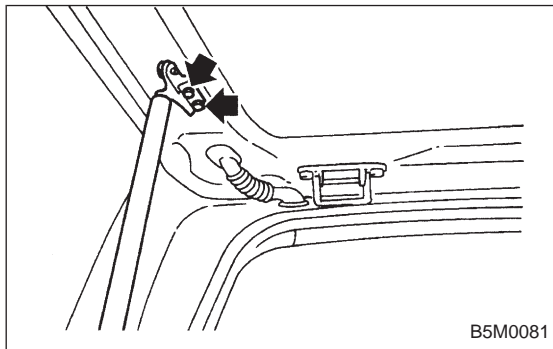

- 7) Gas stay
 - (1) Completely open rear gate.
 - (2) Remove bolts which hold gas stay to rear gate.

CAUTION:

● Be careful because rear gate drops while removing bolts. Have an assistant support it while removing bolts.

● Be sure to place a folded cloth between rear gate and body to prevent scratches.

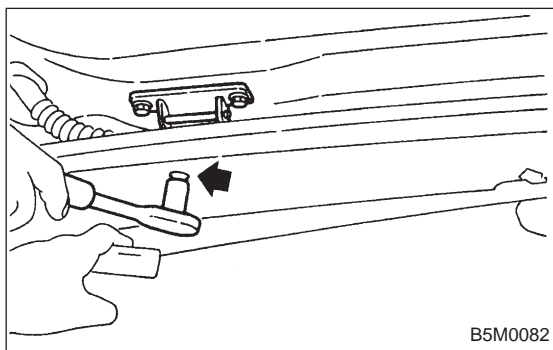

- 8) Remove the bolts which hold rear gate to hinge and then detach rear gate.

3. Rear Gate

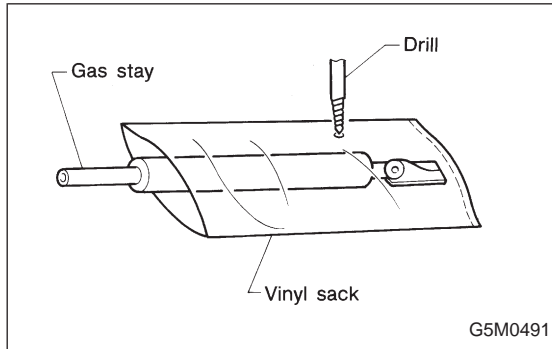
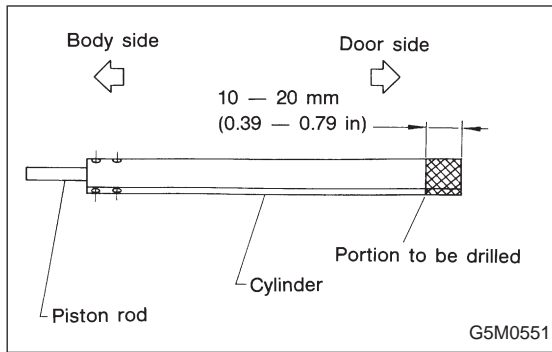

9) General precautions in handling rear gate gas stay.

CAUTION:

- Do not attempt to disassemble gas stay because its cylinder is filled with gas.
- Before discarding gas stay, place it at a slight angle with the cylinder body side facing up and drill a 2 to 3 mm (0.08 to 0.12 in) dia. hole to completely discharge the content. (Gas is odorless, colorless and harmless; however, metal powder may come out of the hole.)

- It is good practice to place a vinyl sack over it before drilling the hole because oil may spurt out. Be careful to prevent vinyl cover from becoming entangled on the drill.

- Be careful not to scratch the exposed section of piston rod or allow oil or paint to come in contact with it.

- Do not attempt to rotate the extended piston rod.

10) Installation is in the reverse order of removal.

CAUTION:

- Be sure to add sealer to hinge.
- When installing rear gate, be careful not to damage coating on body and rear gate.

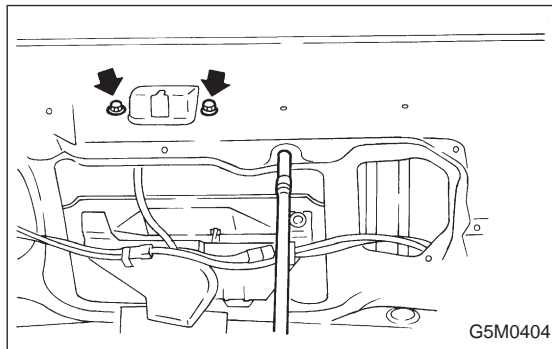
**2. LATCH**

- 1) Remove trim panel.
- 2) Disengage rod from holder (= key cylinder).
- 3) Remove bolts from auto-door lock actuator.
- 4) Remove bolts from latch, and detach latch.
- 5) Disconnect rear gate switch connector.
- 6) Disconnect auto-door lock actuator connector.
- 7) Detach latch.
- 8) Installation is in the reverse order of removal.

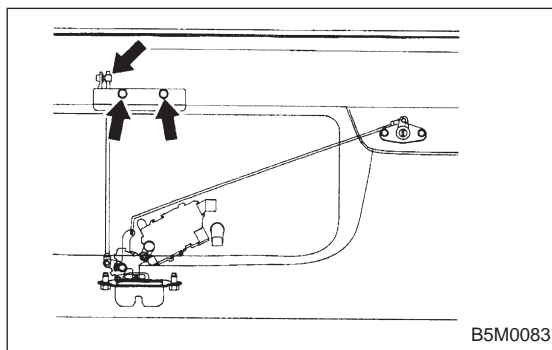
**3. OUTER HANDLE**

- 1) Remove trim panel.
- 2) Disconnect rod from outer handle.
- 3) Remove two nuts used to hold outer handle to the inside of rear gate, and detach outer handle.

CAUTION:

Be careful not to damage packing when removing outer handle.

4) Installation is in the reverse order of removal.

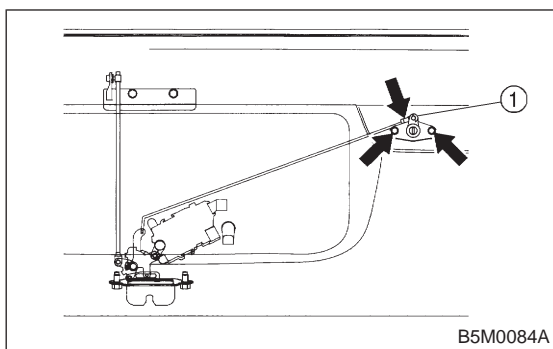

4. KEY CYLINDER

- 1) Remove trim panel.
- 2) Disengage rod from holder ①.
- 3) Remove nut from key cylinder, and detach key cylinder.
- 4) Installation is in the reverse order of removal.

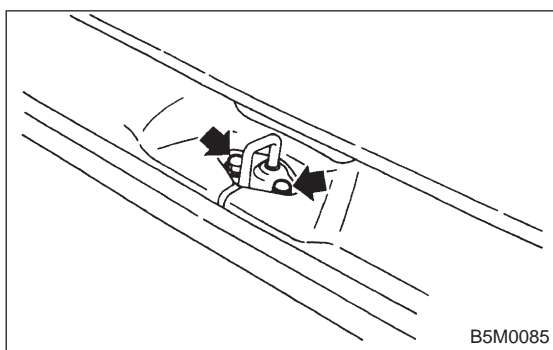

5. STRIKER

Remove two bolts from striker and detach striker.

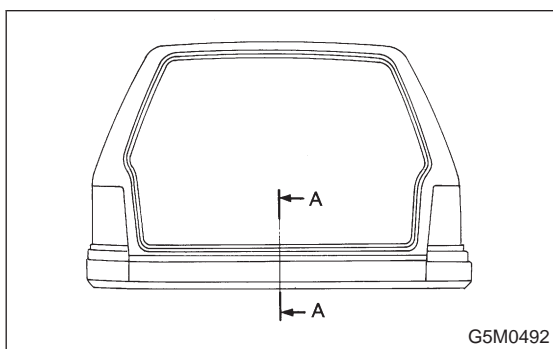

6. WEATHERSTRIP

- 1) Place weatherstrip so that its joints meet at lower center of vehicle body, and install by inserting flanged portion from below, as shown in section A—A in figure.
- 2) Tap along entire length with a rubber hammer to firmly insert body flange into weatherstrip.

CAUTION:

- Be careful not to install in wrong direction.
- Install weatherstrip carefully and firmly.

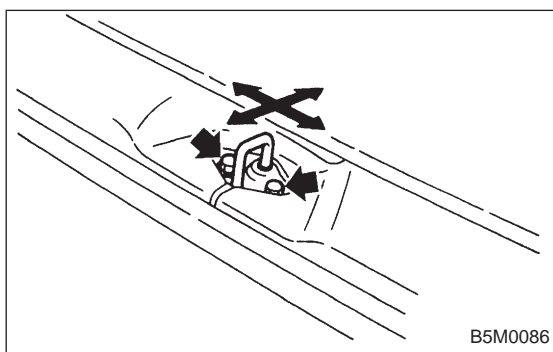
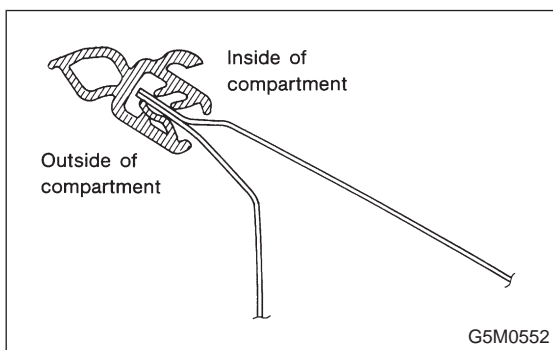

B: ADJUSTMENT

- 1) Loosen striker screw.
- 2) For lateral adjustment, align striker and latch at their centers.