

## 9. Spot Light

### A: REMOVAL AND INSTALLATION

#### 1. SPOT LIGHT AND SWITCH

- 1) Pry spot light lens off using a screwdriver.
- 2) Remove screws which secure spot light body.
- 3) Remove spot light body while disconnecting connector(s).

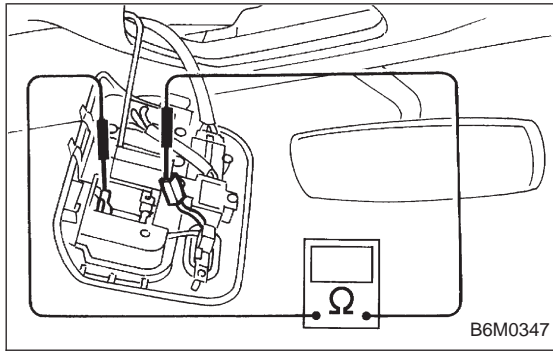

### B: INSPECTION

#### 1. SPOT LIGHT SWITCH

Move switch and check continuity between terminal of spot light switch connector and steel plate as shown.

Switch position	Connector terminal	Plate
Open (OFF)		
Push in (ON)	○	○

## 10. Front Wiper and Washer

### A: ON-CAR SERVICES

#### 1. ADJUSTMENT

- 1) Turn the wiper switch to OFF position.
- 2) Adjust blades in original position as shown in figure by changing wiper arm installation.

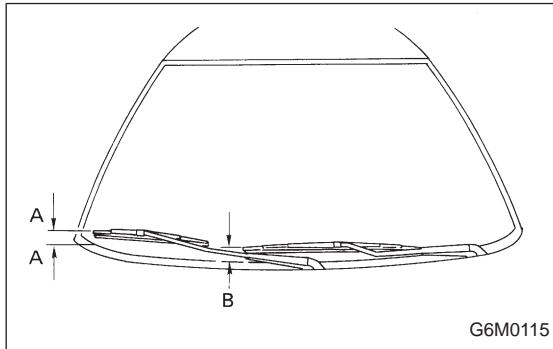

**Original position:**

**A: 25 — 30 mm (0.98 — 1.18 in)**

**B: 35 — 40 mm (1.38 — 1.57 in)**

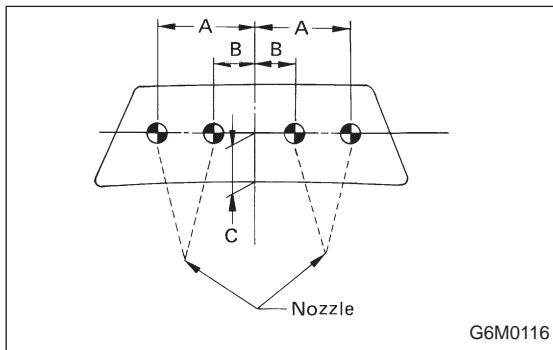

3) Stop the vehicle.

4) Adjust washer ejecting point on windshield glass as shown in figure.

**Ejecting point:**

**A: 375 mm (14.76 in)**

**B: 150 mm (5.91 in)**

**C: 380 mm (14.96 in)**