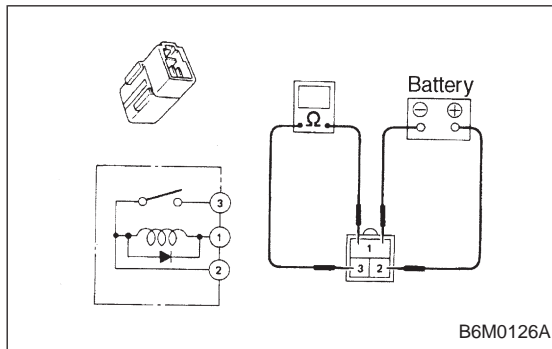

**B: INSPECTION****1. HORN SWITCH**

Ensure that horn switch is free from the following defects:

- 1) Burned or shorted contacts
- 2) Broken or weak spring
- 3) Damaged harness
- 4) Worn or corroded mating surface of horn plate

**2. HORN RELAY**

Check continuity between terminals as indicated in table below, when connecting the battery to terminals No. 1 and No. 2.

When current flows.	Between terminals No. 2 and No. 3	Continuity exists.
When current does not flow.	Between terminals No. 2 and No. 3	Continuity does not exist.
	Between terminals No. 1 and No. 2	Continuity exists.

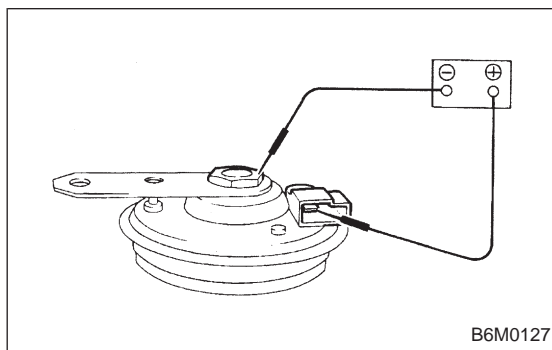
**3. HORN**

Make sure that horn sounds when battery voltage is applied between connector terminal and horn body.

**4. CIGARETTE LIGHTER**

- 1) Remove plug. Then, check element's contact for wear, and element for accumulation of ashes, foreign particles, etc.
- 2) Check element for discontinuity.
- 3) Remove socket and clean element. Then, check for wear or foreign particles on element's contact and mating surface.
- 4) Ensure that cigarette lighter returns within 20 seconds after it is turned to ON.

**16. Power Window****A: REMOVAL AND INSTALLATION****1. MAIN SWITCH, SUB SWITCH AND POWER WINDOW MOTOR**

Refer to 5-2 [W2A2] as for removal and installation of power window main switch, sub switch and motor.

**NOTE:**

To remove the power window motor, it is necessary to disassemble the door component parts.

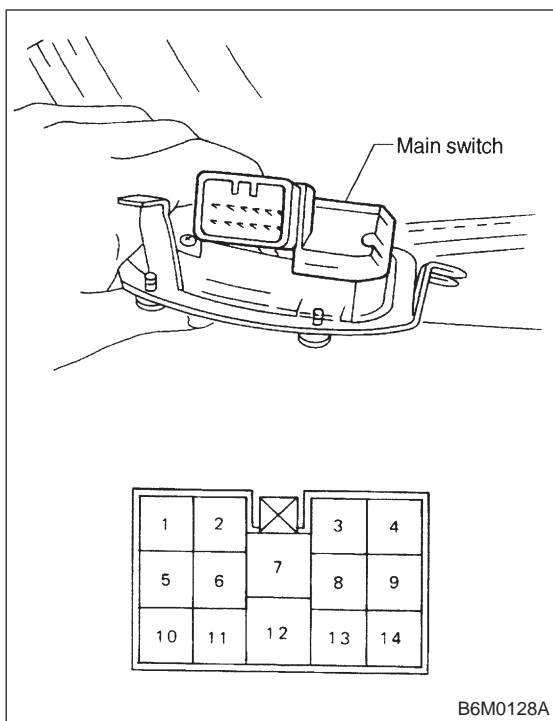

**B: INSPECTION**

**1. MAIN SWITCH**

Set power window main switch to each position and check continuity between terminals as indicated in table below:

**LHD model**

Window lock switch	Switch	Front RH				Front LH				Rear RH				Rear LH			
	Position	7	14	9	12	7	13	8	12	7	6	11	12	7	10	5	12
NORMAL	UP	<input type="radio"/>	<input type="radio"/>	<input type="radio"/>	<input type="radio"/>	<input type="radio"/>	<input type="radio"/>	<input type="radio"/>	<input type="radio"/>	<input type="radio"/>	<input type="radio"/>	<input type="radio"/>	<input type="radio"/>	<input type="radio"/>	<input type="radio"/>	<input type="radio"/>	<input type="radio"/>
	OFF		<input type="radio"/>	<input type="radio"/>	<input type="radio"/>		<input type="radio"/>	<input type="radio"/>	<input type="radio"/>		<input type="radio"/>	<input type="radio"/>	<input type="radio"/>		<input type="radio"/>	<input type="radio"/>	<input type="radio"/>
	DOWN	<input type="radio"/>		<input type="radio"/>		<input type="radio"/>		<input type="radio"/>		<input type="radio"/>		<input type="radio"/>		<input type="radio"/>		<input type="radio"/>	
LOCK	UP	<input type="radio"/>	<input type="radio"/>			<input type="radio"/>	<input type="radio"/>	<input type="radio"/>	<input type="radio"/>	<input type="radio"/>	<input type="radio"/>			<input type="radio"/>	<input type="radio"/>		
	OFF		<input type="radio"/>	<input type="radio"/>			<input type="radio"/>	<input type="radio"/>	<input type="radio"/>		<input type="radio"/>	<input type="radio"/>			<input type="radio"/>	<input type="radio"/>	
	DOWN	<input type="radio"/>		<input type="radio"/>		<input type="radio"/>		<input type="radio"/>		<input type="radio"/>		<input type="radio"/>		<input type="radio"/>		<input type="radio"/>	

**RHD model**

Window lock switch	Switch	Front RH				Front LH				Rear RH				Rear LH			
	Position	7	11	6	12	7	10	5	12	7	9	14	12	7	13	8	12
AUTO UP		<input type="radio"/>	<input type="radio"/>	<input type="radio"/>	<input type="radio"/>												
UP		<input type="radio"/>	<input type="radio"/>	<input type="radio"/>	<input type="radio"/>	<input type="radio"/>	<input type="radio"/>	<input type="radio"/>	<input type="radio"/>	<input type="radio"/>	<input type="radio"/>	<input type="radio"/>	<input type="radio"/>	<input type="radio"/>	<input type="radio"/>	<input type="radio"/>	<input type="radio"/>
OFF			<input type="radio"/>	<input type="radio"/>	<input type="radio"/>		<input type="radio"/>	<input type="radio"/>	<input type="radio"/>		<input type="radio"/>	<input type="radio"/>	<input type="radio"/>		<input type="radio"/>	<input type="radio"/>	<input type="radio"/>
DOWN		<input type="radio"/>		<input type="radio"/>		<input type="radio"/>		<input type="radio"/>		<input type="radio"/>		<input type="radio"/>		<input type="radio"/>		<input type="radio"/>	
AUTO DOWN		<input type="radio"/>		<input type="radio"/>													

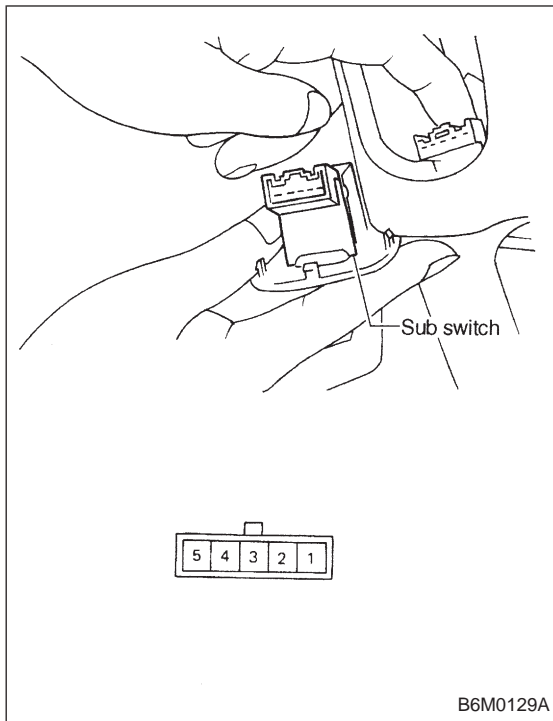

B6M0129A

**2. SUB SWITCH**

Set power window sub switch to each position and check continuity between terminals as indicated in table below:

Terminal Switch position	5	1	3	4	2
UP	○		○	○	○
↕					
OFF		○	○	○	○
↕					
DOWN	○	○		○	○

**3. POWER WINDOW MOTOR**

- 1) Make sure that power window motor rotates properly when battery voltage is applied to terminals of motor connector.
- 2) Change polarity of battery connections to terminals to ensure that motor rotates in reverse direction.

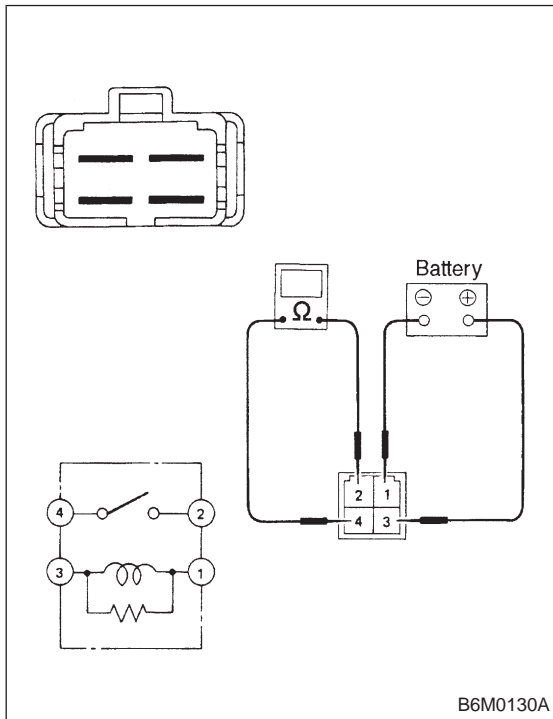

B6M0130A

**4. POWER WINDOW RELAY**

Check continuity between terminals as indicated in table below, when connecting the battery to terminal No. 1 and No. 3.

When current flows.	Between terminals No. 2 and No. 4	Continuity exists.
When current does not flow.	Between terminals No. 2 and No. 4	Continuity does not exist.
	Between terminals No. 1 and No. 3	Continuity exists.