

B: INSTALLATION

CAUTION:

Leave fuel filler cap open when tightening nuts, to prevent fuel from flowing out through fuel delivery and return pipes. Close fuel filler cap after tightening nuts.

Installation is in the reverse order of removal. Do the following:

- (1) Always use new gaskets.
- (2) Ensure sealing portion is free from fuel or foreign particles before installation.
- (3) Tighten nuts in numerical sequence shown in Figure to specified torque.

Tightening torque:

4.4±1.5 N·m (0.45±0.15 kg-m, 3.3±1.1 ft-lb)

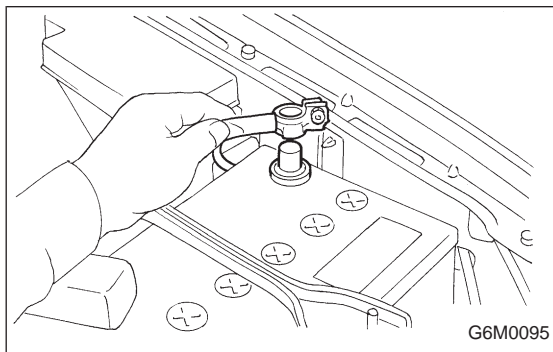

9. Fuel Tank Pressure Sensor (2200 cc AWD Model)

A: REMOVAL AND INSTALLATION

1) Disconnect battery ground cable.

2) Remove trims.

- 4 door model:

Remove right trunk side trim.

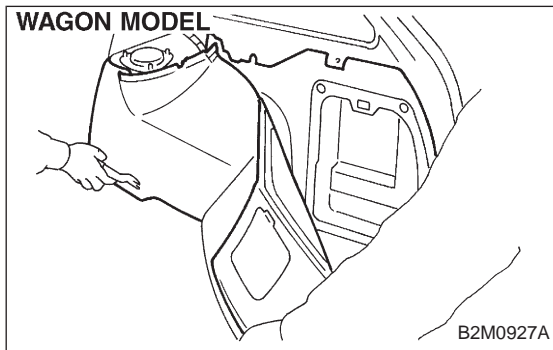
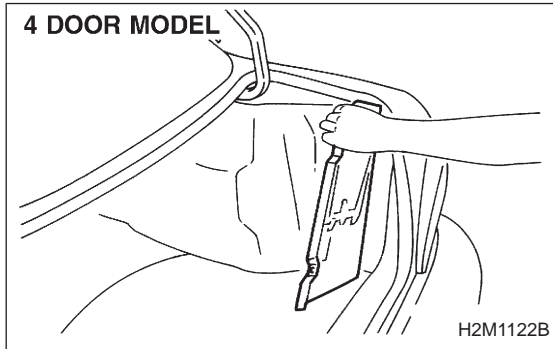

- Wagon model:

- (1) Remove right rear quarter upper rear trim.
- (2) Remove right strut cap.
- (3) Remove right rear quarter pillar lower trim.

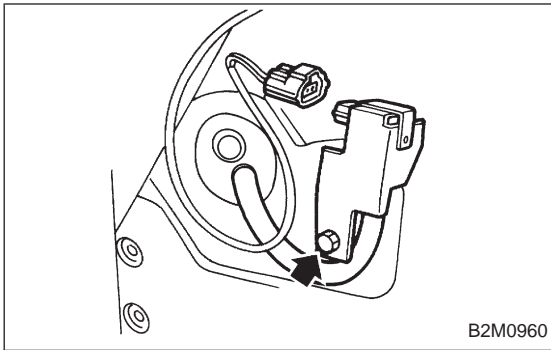

- 3) Disconnect connector from fuel tank pressure sensor.
- 4) Remove bolts which install fuel tank pressure sensor bracket on body.

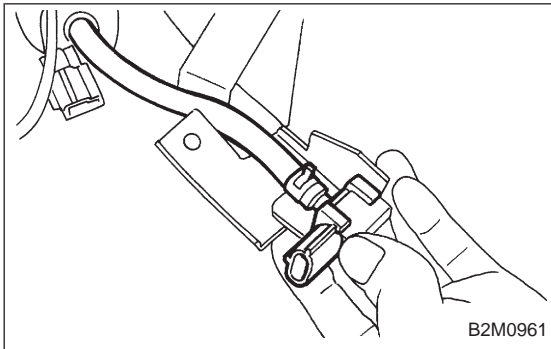

- 5) Disconnect hose from fuel tank pressure sensor.
- 6) Remove fuel tank pressure sensor from bracket.
- 7) Installation is in the reverse order of removal.

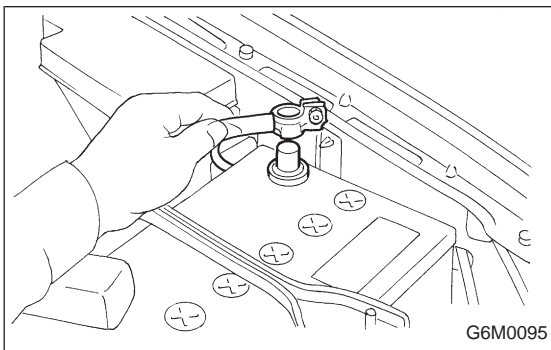

10. Pressure Control Solenoid Valve (2200 cc AWD Model)

A: REMOVAL AND INSTALLATION

- 1) Disconnect battery ground cable.
- 2) Lift-up the vehicle.

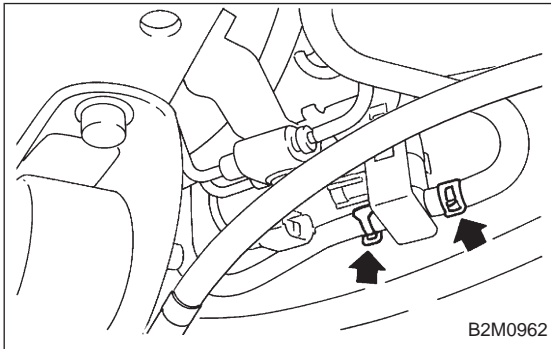

- 3) Disconnect evaporation hoses from pressure control valve.
- 4) Disconnect connector from pressure control valve.

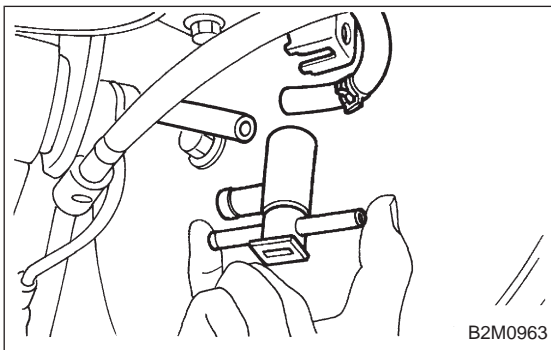

- 5) Remove pressure control valve from bracket.
- 6) Installation is in the reverse order of removal.