

12. Fuel Level Sensor (2200 cc AWD Model)

A: REMOVAL

1) Disconnect battery ground cable.

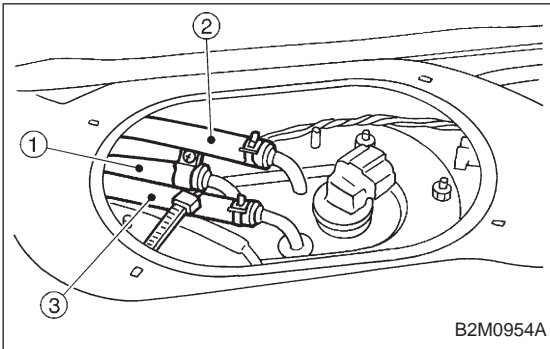

2) Release fuel pressure. <Ref. to 2-8 [W1A0].>

3) Disconnect fuel delivery hose ①, return hose ② and jet pump hose ③.

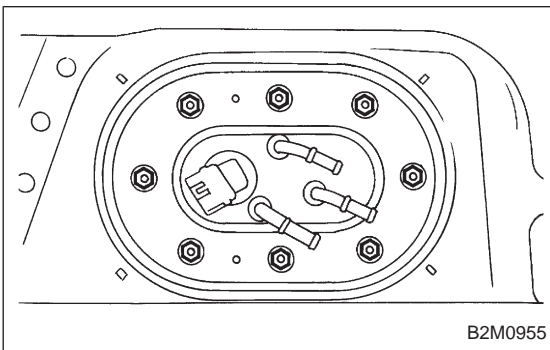

4) Remove nuts which install fuel pump assembly onto fuel tank.

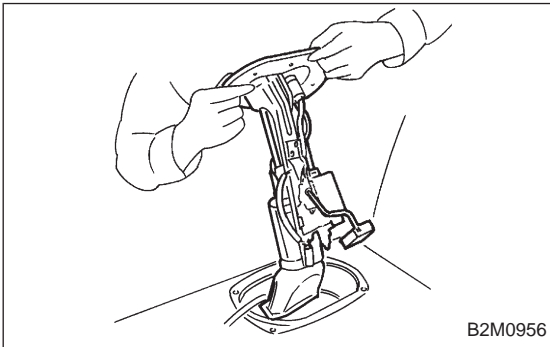

5) Take off fuel pump assembly from fuel tank.

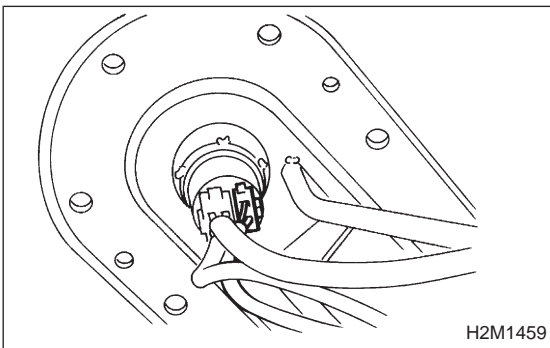

6) Disconnect connector from fuel pump.

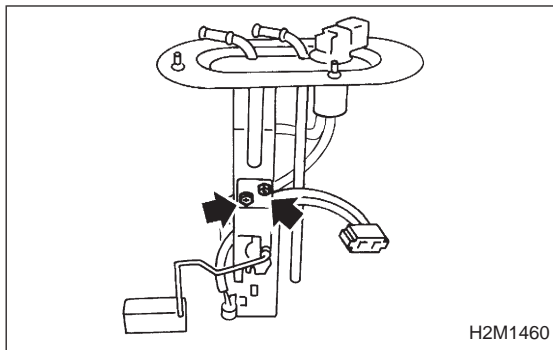

7) Remove two screws fixing bracket on fuel pump assembly.

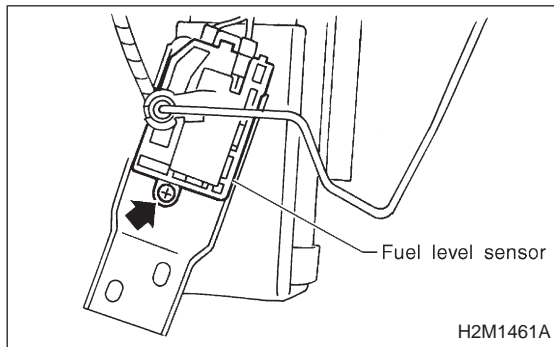

8) Remove one screw fixing fuel level sensor on bracket.
9) Remove fuel level sensor from fuel pump assembly.

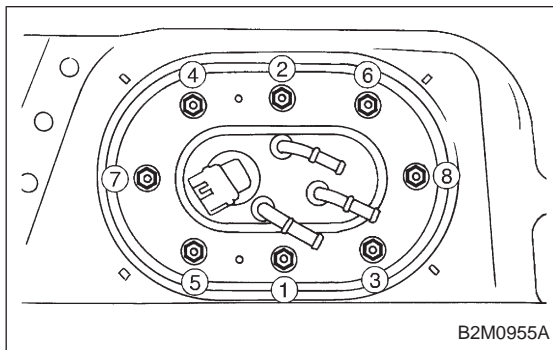

B: INSTALLATION

CAUTION:

Leave fuel filler cap open when tightening nuts, to prevent fuel from flowing out through fuel delivery and return pipes. Close fuel filler cap after tightening nuts.

Installation is in the reverse order of removal. Do the following:

- (1) Always use new gaskets.
- (2) Ensure sealing portion is free from fuel or foreign particles before installation.
- (3) Tighten nuts in numerical sequence shown in Figure to specified torque.

Tightening torque:

$4.4 \pm 1.5 \text{ N}\cdot\text{m}$ ($0.45 \pm 0.15 \text{ kg}\cdot\text{m}$, $3.3 \pm 1.1 \text{ ft}\cdot\text{lb}$)

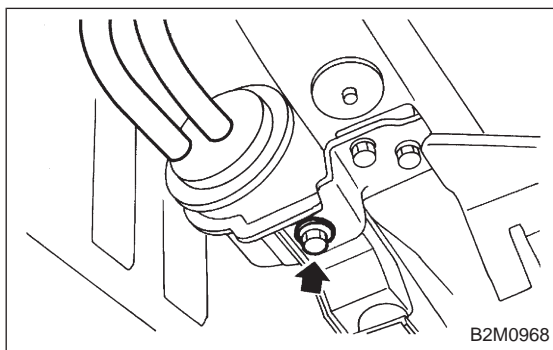

13. Air Filter (2200 cc AWD Model)

A: REMOVAL AND INSTALLATION

- 1) Remove canister. <Ref. to 2-1 [W3A2].>
- 2) Remove two hoses from air filter.
- 3) Remove flange nut from bracket.
- 4) Installation is in the reverse order of removal.