

2. Oil Pan and Oil Strainer

A: REMOVAL

- 1) Remove front wheels.
- 2) Remove air intake duct.
- 3) Disconnect connector from front oxygen sensor.

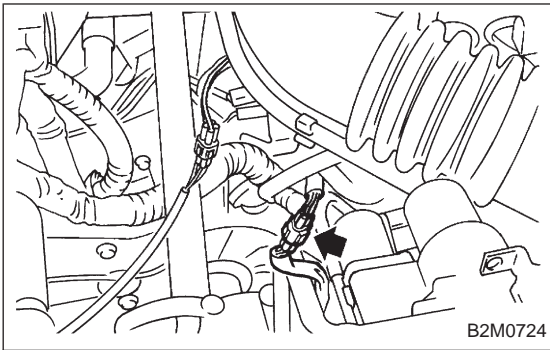

- 4) Disconnect connector from rear oxygen sensor. (California 2200 cc model only)

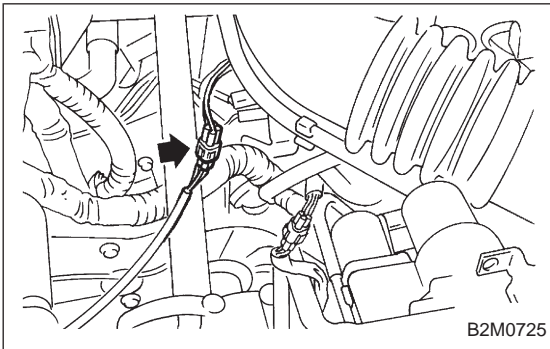

- 5) Remove pitching stopper.

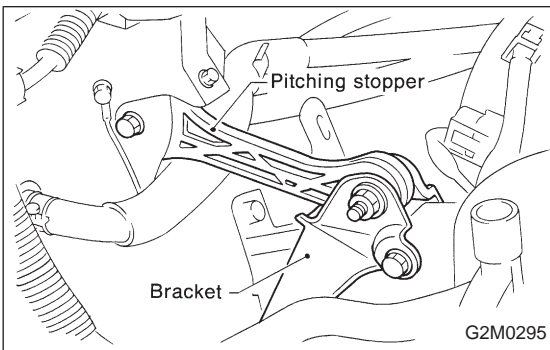

- 6) Remove radiator upper brackets.

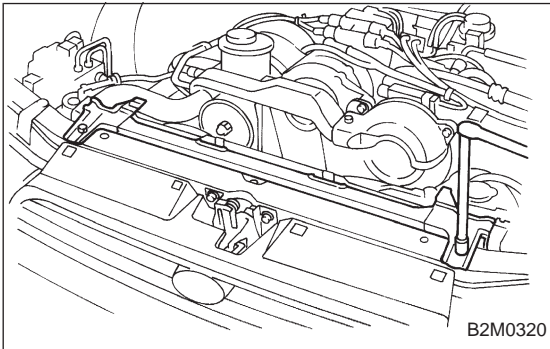

- 7) Support engine with a lifting device and wire ropes.
- 8) Lift-up the vehicle.

CAUTION:

At this time, raise up wire ropes.

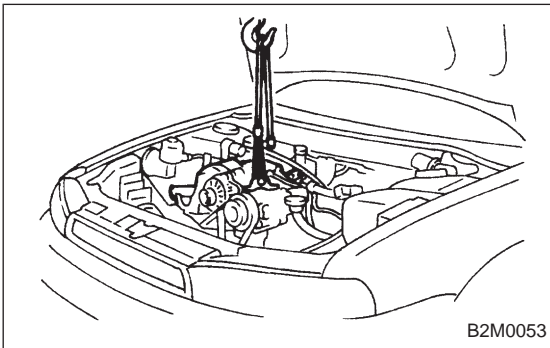

2. Oil Pan and Oil Strainer

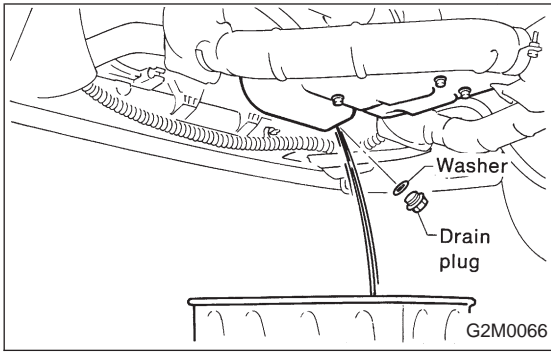

9) Drain engine oil.

Set container under the vehicle, and remove drain plug from oil pan.

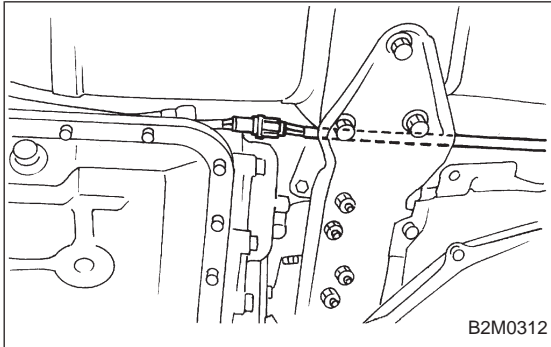

10) Disconnect connector from rear oxygen sensor. (Except California 2200 cc model)

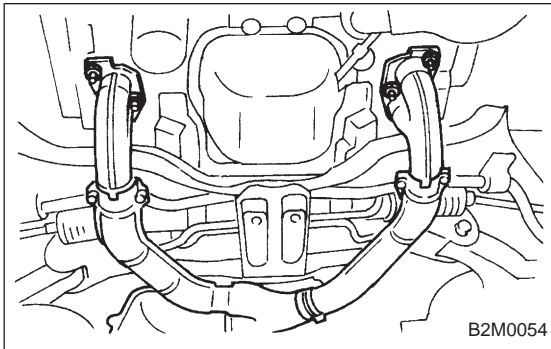

11) Remove front exhaust pipe.

- (1) Separate front catalytic converter from center exhaust pipe.
- (2) Remove front exhaust pipe from engine.
- (3) Remove bolt which installs front exhaust pipe on bracket.

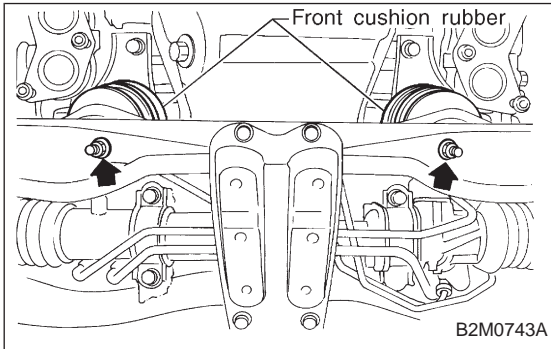

12) Remove nuts which install front cushion rubber onto front crossmember.

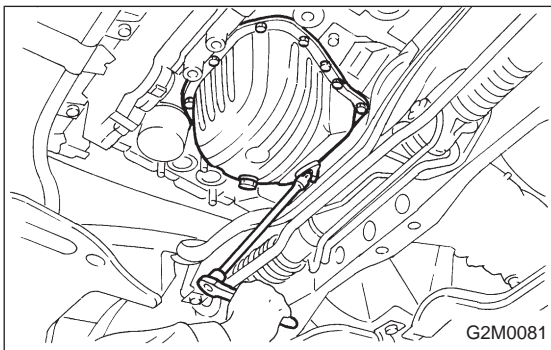

13) Remove bolts which install oil pan on cylinder block while raising up engine.

14) Insert oil pan cutter blade between cylinder block-to-oil pan clearance.

CAUTION:

Do not use a screwdriver or similar tool in place of oil pan cutter.

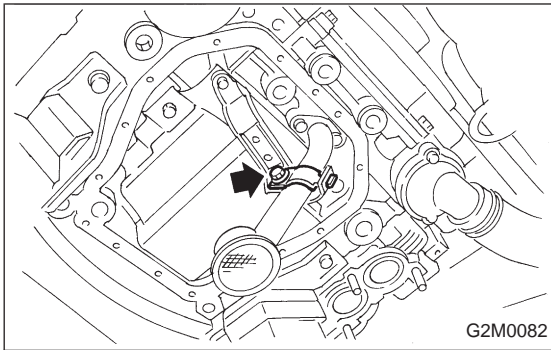

15) Separate oil strainer from oil strainer stay.

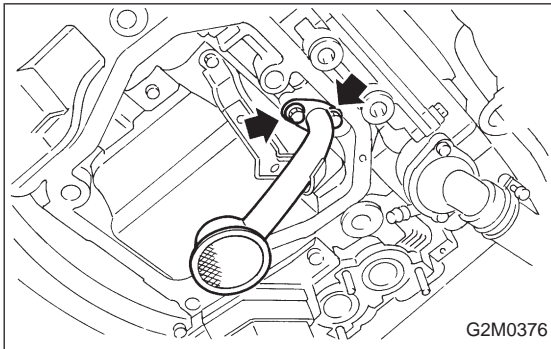

16) Remove oil strainer.

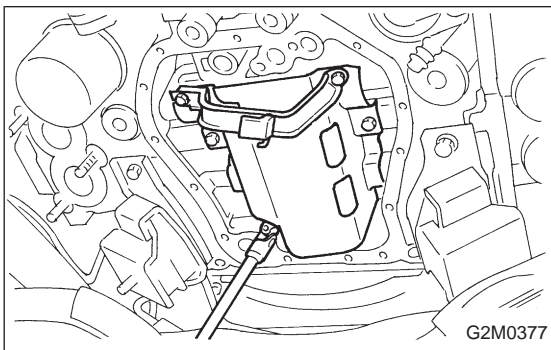

17) Remove baffle plate and oil strainer stay.

B: INSPECTION

By visual check make sure oil pan, oil strainer, oil strainer stay and baffle plate are not damaged.

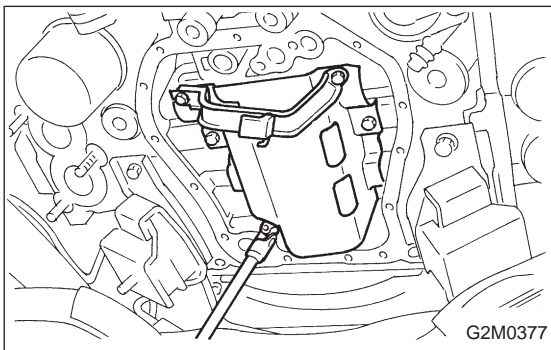

C: INSTALLATION

CAUTION:

Before installing oil pan, clean sealant from oil and engine block.

1) Install baffle plate and oil strainer stay.

Tightening torque:

5 N·m (0.5 kg-m, 3.6 ft-lb)

2. Oil Pan and Oil Strainer

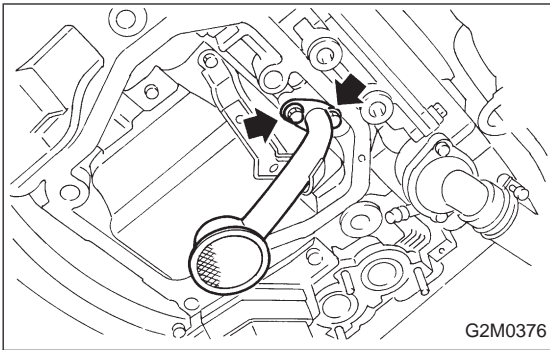

2) Install oil strainer onto baffle plate.

CAUTION:

Replace O-ring with a new one.

Tightening torque:

9.8 N·m (1.0 kg-m, 7 ft-lb)

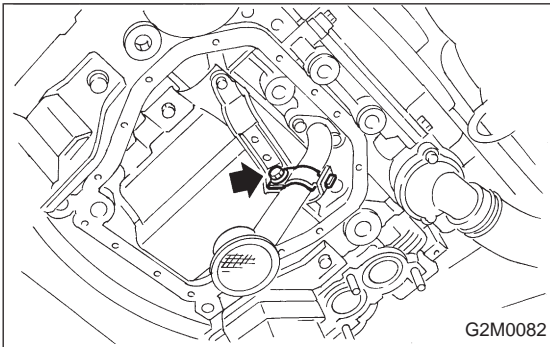

3) Hold oil strainer to oil strainer stay.

Tightening torque:

9.8 N·m (1.0 kg-m, 7 ft-lb)

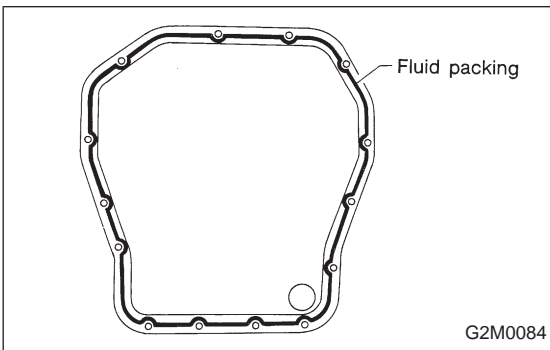

4) Apply fluid packing to mating surfaces and install oil pan.

Fluid packing:

THREE BOND 1207C or equivalent

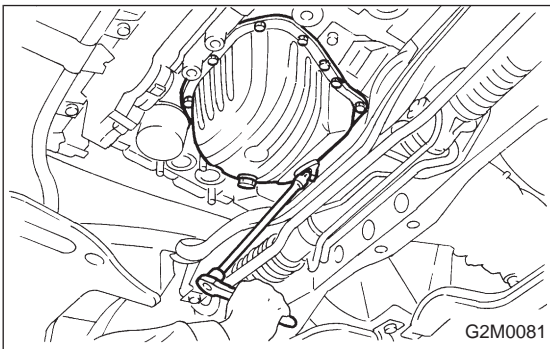

5) Tighten bolts which install oil pan onto engine block.

Tightening torque:

9.8 N·m (1.0 kg-m, 7 ft-lb)

6) Tighten drain plug.

Tightening torque:

44 ^{+4.8}/₀ N·m (4.5 ^{+0.5}/₀ kg-m, 33 ^{+3.6}/₀ ft-lb)

CAUTION:

Replace drain plug gasket with new one.

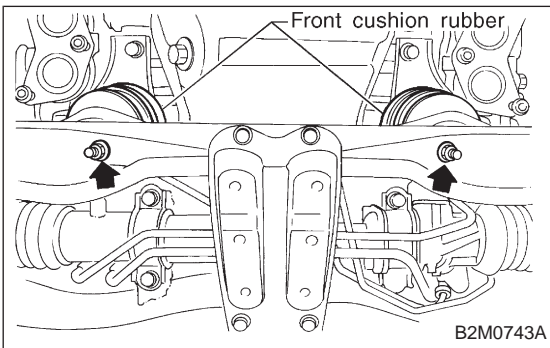

7) Lower engine onto front crossmember.

8) Tighten nuts which install front cushion rubber onto front crossmember.

Tightening torque:

69±15 N·m (7.0±1.5 kg-m, 51±11 ft-lb)

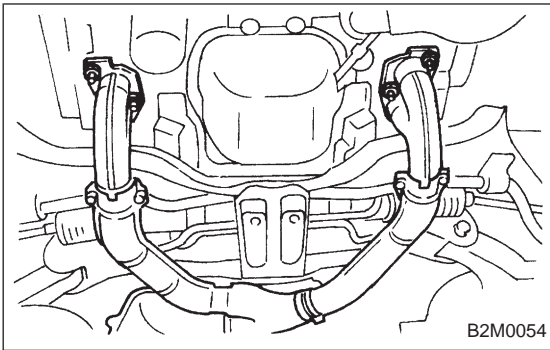

9) Install front exhaust pipe.

CAUTION:

Always use the new gaskets.

- (1) Place front exhaust pipe on bracket.
- (2) Tighten nuts which install front exhaust pipe on engine.

Tightening torque:

30 ± 5 N·m (3.1 ± 0.5 kg·m, 22.4 ± 3.6 ft·lb)

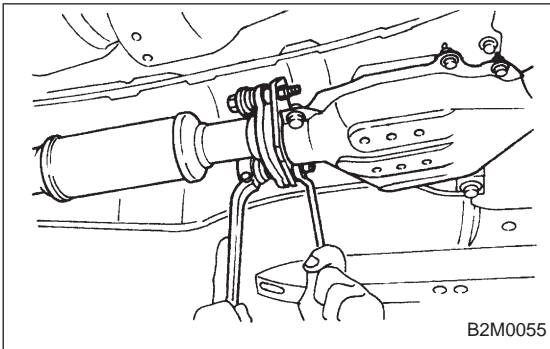

- (3) Tighten nuts which install front catalytic converter to center exhaust pipe.

Tightening torque:

35 ± 5 N·m (3.6 ± 0.5 kg·m, 26.0 ± 3.6 ft·lb)

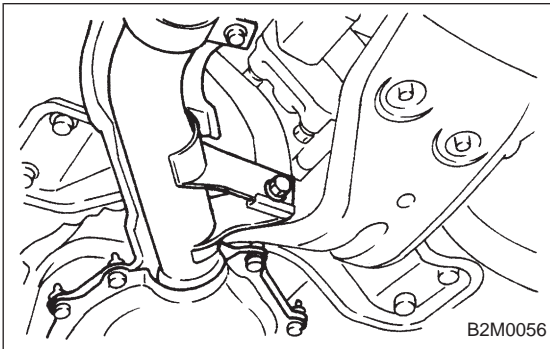

- (4) Tighten bolt which installs front exhaust pipe on bracket.

Tightening torque:

24 ± 3 N·m (2.4 ± 0.3 kg·m, 17.4 ± 2.2 ft·lb)

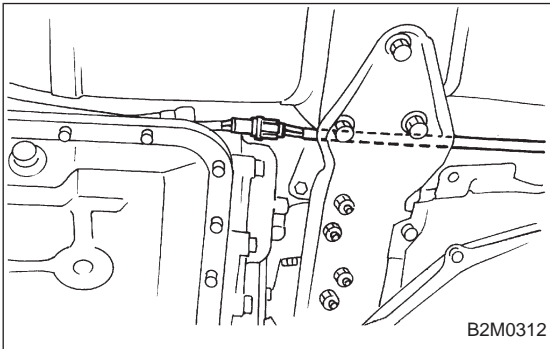

10) Connect connector to rear oxygen sensor. (Except California 2200 cc model)

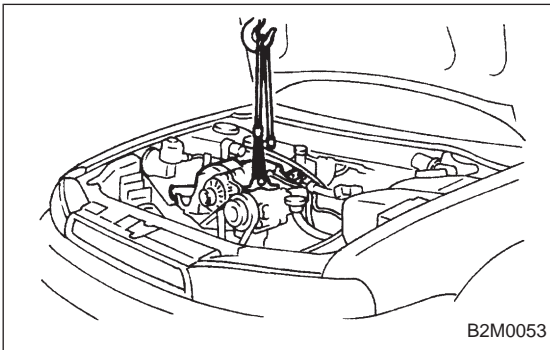

11) Lower the vehicle.

CAUTION:

At this time, lower lifting device and release steel cables.

12) Remove lifting device and steel cables.

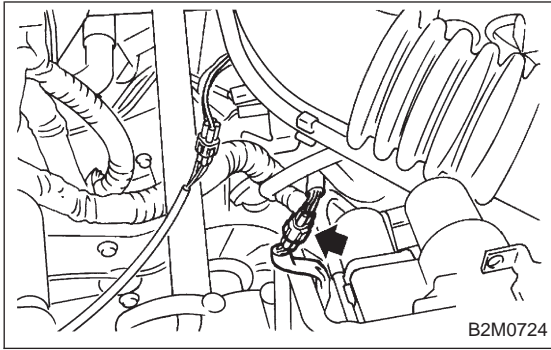

13) Connect connector to front oxygen sensor.

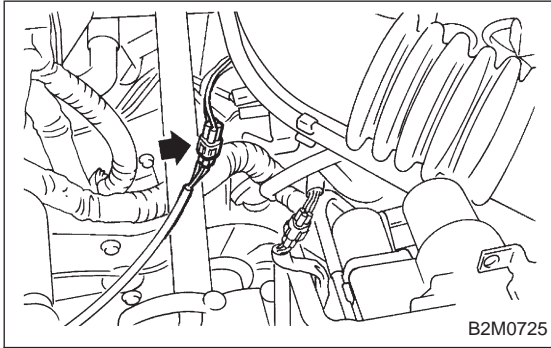

14) Connect connector to rear oxygen sensor. (California 2200 cc model only)

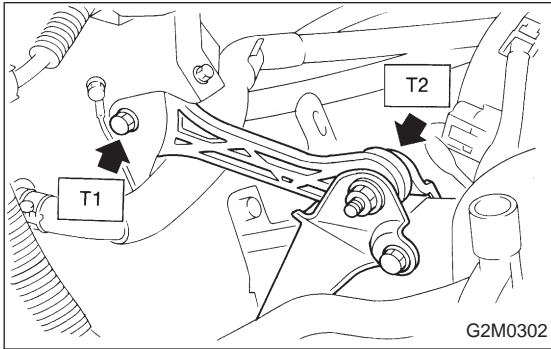

15) Install pitching stopper.

Tightening torque:

T1: 49 ± 5 N·m (5.0 ± 0.5 kg-m, 36.2 ± 3.6 ft-lb)

T2: 57 ± 10 N·m (5.8 ± 1.0 kg-m, 42 ± 7 ft-lb)

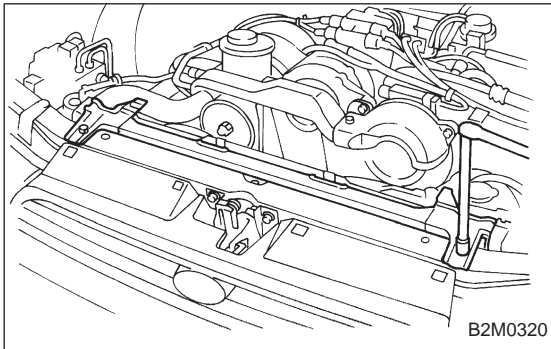

16) Install radiator upper brackets.

Tightening torque:

12 ± 3 N·m (1.2 ± 0.3 kg-m, 8.7 ± 2.2 ft-lb)

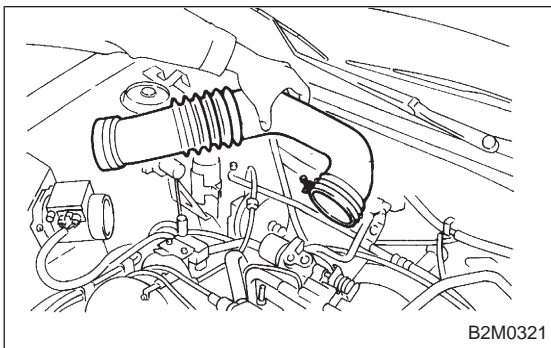

17) Install air intake duct.

18) Fill engine oil through filler pipe up to upper point of level gauge. <Ref. to 1-5 [03A0].>

Engine oil capacity:

2200 cc ; Upper level

4.0 l (4.2 US qt, 3.5 Imp qt)

Lower level

3.0 l (3.2 US qt, 2.6 Imp qt)

2500 cc ; Upper level

4.5 l (4.8 US qt, 4.0 Imp qt)

Lower level
 3.5 l (3.7 US qt, 3.1 Imp qt)

3. Oil Pressure Switch

A: REMOVAL

- 1) Remove alternator from bracket.
 - (1) Disconnect connector and terminal from generator.

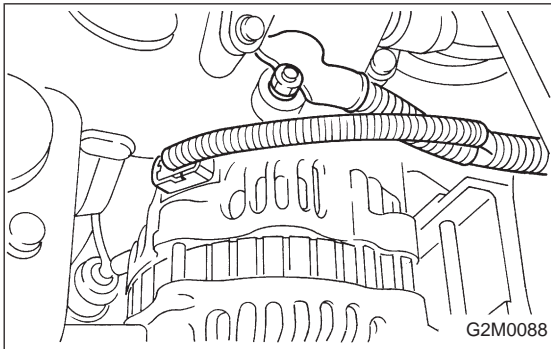

- (2) Remove V-belt cover.
- (3) Loosen lock bolt and slider bolt, and remove front side V-belt.

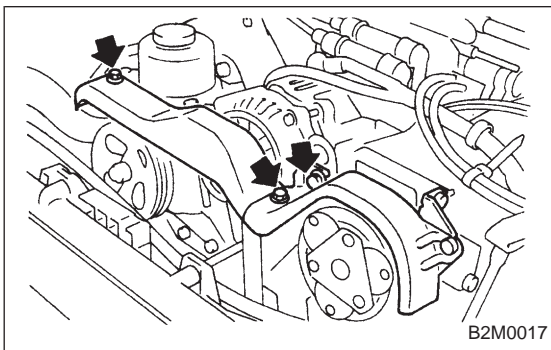

- (4) Remove bolts which install generator on bracket.

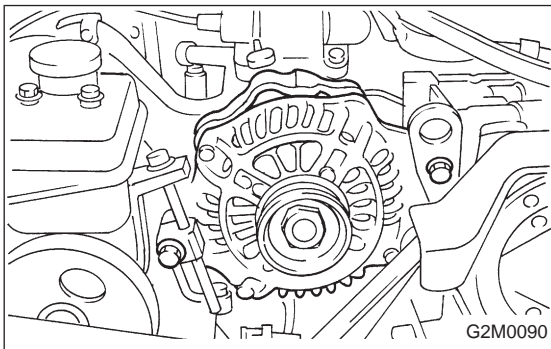

- 2) Disconnect terminal from oil pressure switch.
- 3) Remove oil pressure switch.

