

*Lower level*  
 3.5 l (3.7 US qt, 3.1 Imp qt)

### 3. Oil Pressure Switch

#### A: REMOVAL

- 1) Remove alternator from bracket.
  - (1) Disconnect connector and terminal from generator.

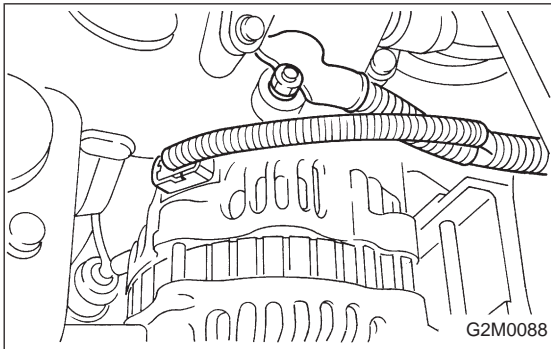

- (2) Remove V-belt cover.
- (3) Loosen lock bolt and slider bolt, and remove front side V-belt.

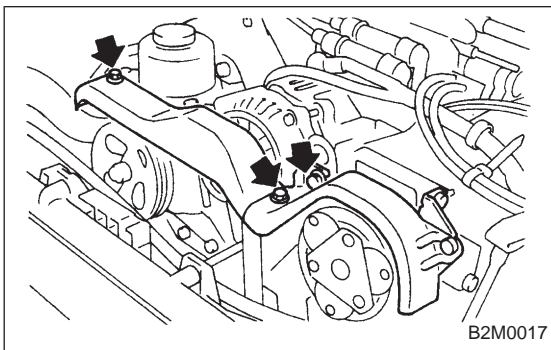

- (4) Remove bolts which install generator on bracket.

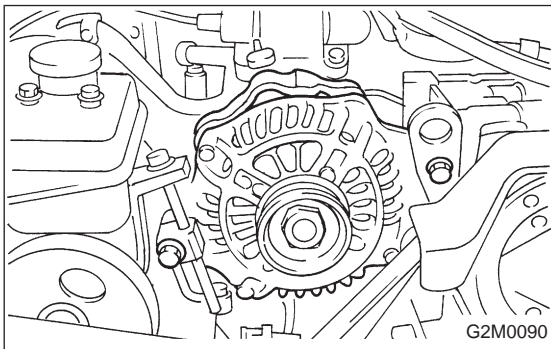

- 2) Disconnect terminal from oil pressure switch.
- 3) Remove oil pressure switch.

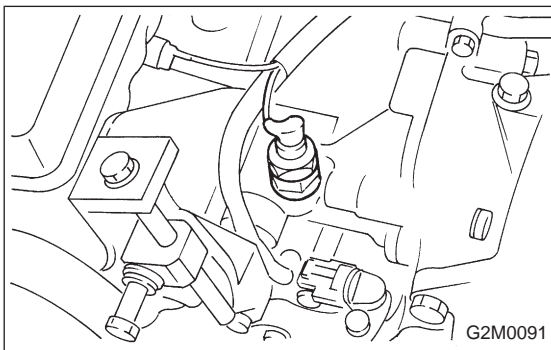

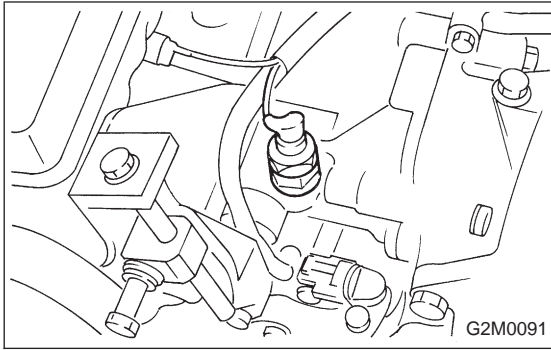
**B: INSTALLATION**

1) Install oil pressure switch onto engine block.

**Tightening torque:**

**$25\pm 3$  N·m ( $2.5\pm 0.3$  kg·m,  $18.1\pm 2.2$  ft·lb)**

2) Connect terminal of oil pressure switch.

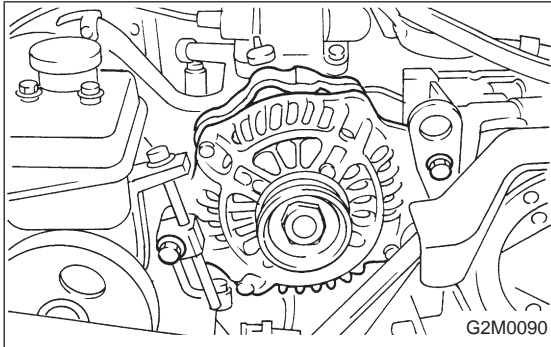

3) Install generator on bracket and temporary tighten installing bolts.

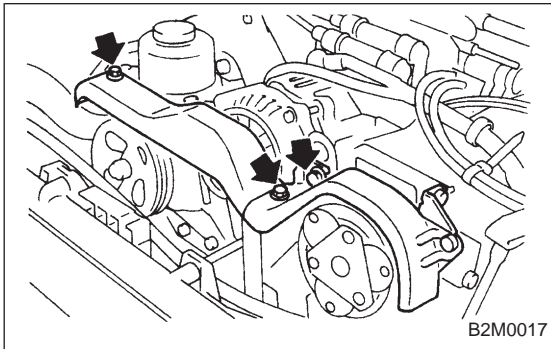

4) Install front side V-belt and adjust it.

<Ref. to 1-5 [01A0].>

5) Install V-belt cover.

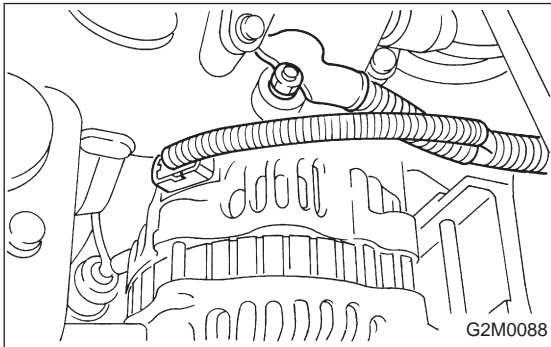

6) Connect connector and terminal to generator.