

## 8. Leak Testing

The following points should be kept in mind when conducting a refrigerant leak test.

- 1) The A/C system to be tested must have an adequate refrigerant charge to begin with.
- 2) The area where the leak test is conducted must be free of wind and drafts, with still air being the ideal condition.
- 3) The atmosphere where the leak test is conducted must be free of refrigerant contamination.
- 4) Operate the A/C system for approx. 10 minutes, then turn the engine off and begin the leak test.
- 5) Refrigerant gas is heavier than air, therefore always hold the probe below the connection being tested.
- 6) When checking for a leak along a length of hose or tube, the leak detector probe must be moved slowly, approx. 25 mm (1 in) per second making sure probe does not come in contact with the component being tested.
- 7) When checking for a leak at a certain point, the leak detector probe must be held at that point for at least 5 seconds.

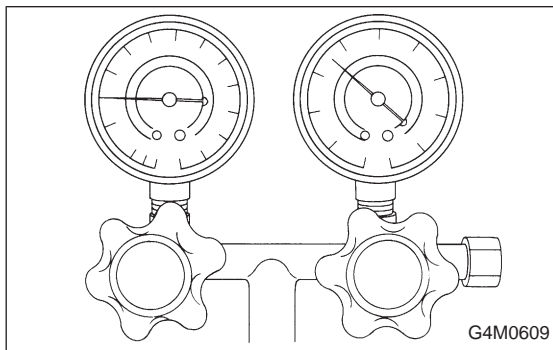

### 1. CHECK THE SYSTEM PRESSURE

With gauges connected to the A/C system, operate the A/C and confirm that the high side pressure is above 690 kPa (7.03 kg/cm<sup>2</sup>, 100 psi). If not, evacuate and charge the system before leak checking (refer to evacuation and charging sections).

### 2. CLEAN CONNECTIONS BEFORE TESTING

Before testing, use a clean shop towel to wipe off refrigerant oil, dirt, or foreign material from all of the connections and components to be tested.

#### NOTE:

Since refrigerant oil absorbs refrigerant, excess oil on or near a connection may falsely signal a leak.

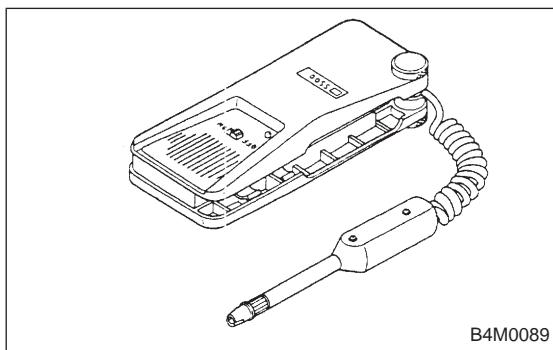

### 3. CALIBRATE LEAK DETECTOR

Refer to the manufacturer's instructions for the particular type of detector used and calibrate the instrument.

#### CAUTION:

**Always make sure that the probe tip filter is clean and free of contamination.**

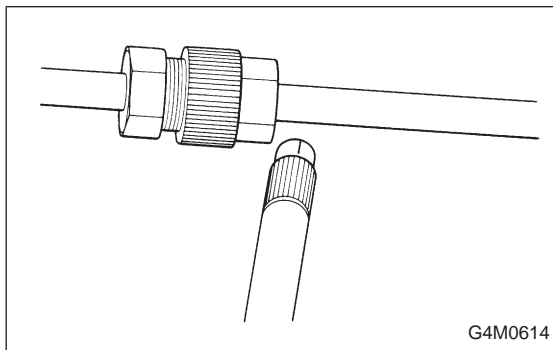
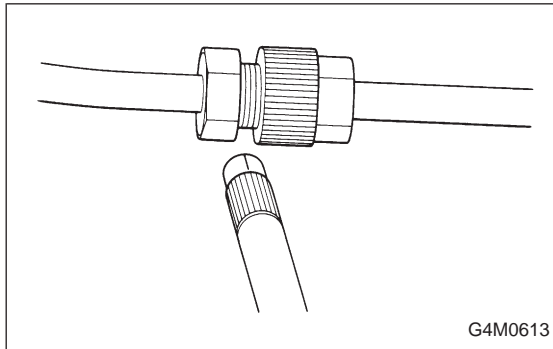
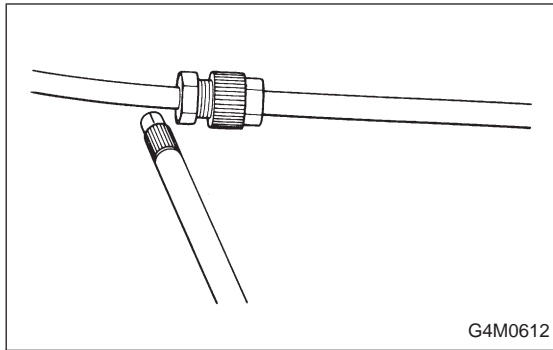

#### 4. LEAK TEST — HIGH-PRESSURE SIDE

Operate the A/C system for approx. 10 minutes, then turn the engine off and begin the leak test.

1) Begin at the connection of the high-pressure tube to the evaporator, and work your way along the high-pressure side of the system to the compressor. There are three places to check on each tube connection.

2) Check the area.

(1) Check the area where the fitting joins the tube.

(2) Check the area where the two parts of the fitting join each other.

(3) Check the area where the nut joins the tube.

3) Check the area of the sight glass and pressure switch (dual switch), and also check the seams of the receiver drier.

4) Check the connections of the tubes to the condenser, and also check any welded joints on the condenser.

#### CAUTION:

**An oily area on the fins of the condenser may indicate a leak.**

5) Check the area where the hoses attach to the compressor.

6) Check around the machined portions of the compressor (where the compressor sections join each other).

7) If equipped, check the thermal limiter on the compressor housing.

8) Check the compressor shaft seal by probing near the center of the compressor clutch pulley.

#### NOTE:

Some shaft seals have a very slight amount of normal leakage [approximately 28 g (1.0 oz) per year].

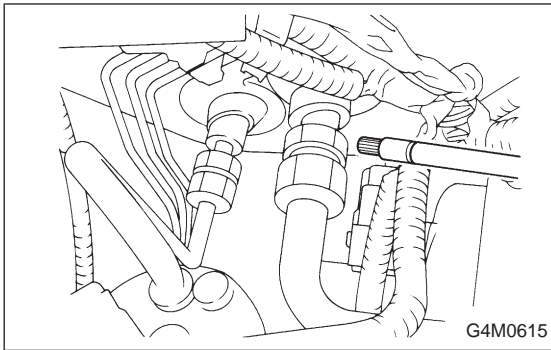

### 5. LEAK TEST — LOW-PRESSURE SIDE

1) Begin at the connection of the low-pressure tube to the evaporator, and work your way along the low-pressure of the system to the compressor. There are three places to check on each tube connection.

2) Check the area.

- (1) Check the area where the fitting joins the tube.
- (2) Check the area where the two parts of the fitting join each other.

(3) Check the area where the nut joins the tube.

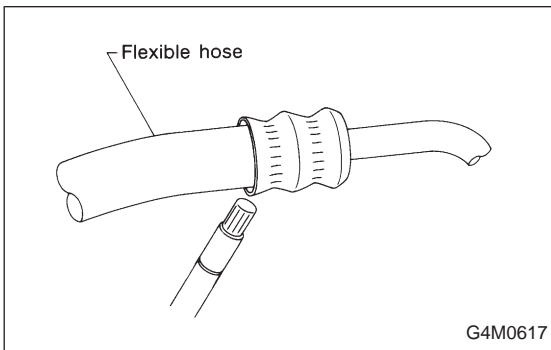
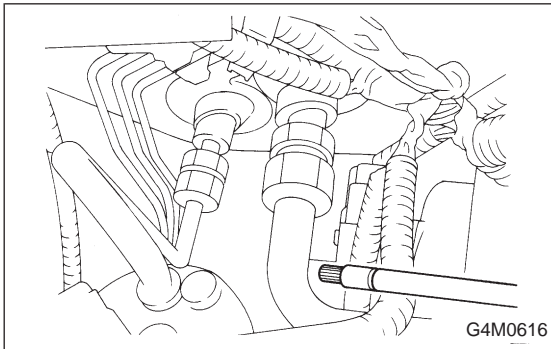

### 6. CHECK THE FLEXIBLE HOSES

Visually inspect the rubber portions of the flexible hoses for cracking. Probe the rubber section, including the ends of any insulators or protectors which may cover sections of the rubber hose, and near the ends where the rubber meets the metal collar.

#### NOTE:

Be certain to move the probe slowly [approximately 25 mm (1 in) per second] when probing along any length of hose or tube.

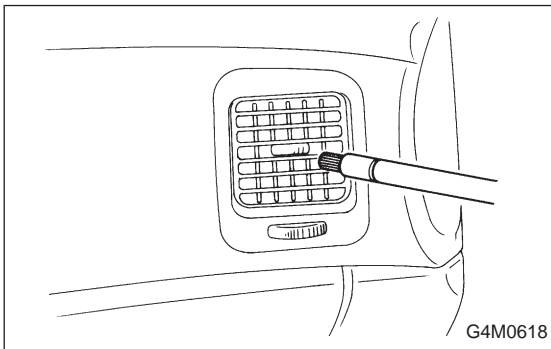

### 7. CHECK THE EVAPORATOR ASSEMBLY

1) Use one or both of the following methods to check the evaporator assembly.

2) Remove the drain hose from the case drain nipple. Hold the probe at the end of the case drain nipple for at least 10 seconds. Be certain to reconnect the drain hose when finished.

3) With the ignition key in the "ACC" position, run the blower on high speed for 1 minute, then turn the blower off. Place the probe in the center instrument panel vent, and turn the blower on low speed for 1 to 2 seconds, then turn the blower off. Leave the probe in the vent for at least 10 seconds.

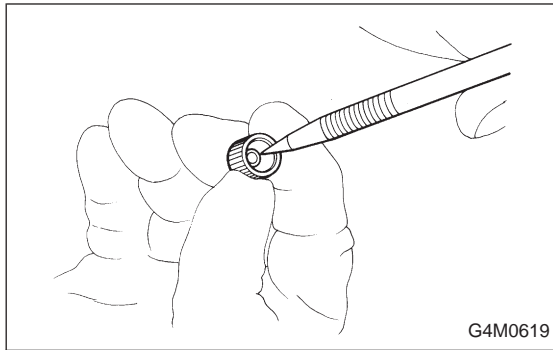

## 8. CHECK THE SERVICE PORT CAPS

Visually inspect the inside of the service port caps. Make sure the rubber seal is in place on the inside of the caps. Disconnect the gauges from the vehicle and install the service port caps.

## 9. Lubrication

### 1. SYSTEM OIL STABILIZATION

Prior to opening the refrigerant system for repairs (except compressor seizure) the system must be stabilized for correct oil replenishment.

Follow these procedures:

- 1) Engine speed set to 1,500 rpm
- 2) A/C "ON"
- 3) Air source to recirculate
- 4) Blower in 4th or high speed position
  - Make sure the air entering the evaporator is above 26.7°C (80°F).
  - The discharge (high) side pressure must be above 588 kPa (6 kg/cm<sup>2</sup>, 85 psi).
- 5) Operate the A/C for 10 minutes.

### 2. SYSTEM DISCHARGE

Slowly, discharge the system starting with the high-pressure side until the pressure drops below 345 kPa (3.52 kg/cm<sup>2</sup>, 50 psi), then open the low-pressure side.

### 3. OIL REPLACEMENT (LHD MODEL)

After stabilization and discharge, replace the component, adding the appropriate amount of oil (ZXL200PG) to the new component before installation.

Evaporator	114 ml (3.9 US fl oz, 4.0 Imp fl oz)
Receiver drier	5 ml (0.2 US fl oz, 0.2 Imp fl oz)
Condenser	2 ml (0.07 US fl oz, 0.07 Imp fl oz)
Hose	1 ml (0.03 US fl oz, 0.04 Imp fl oz)

If the compressor is replaced (after stabilization):

- 1) Drain and measure the oil from the original compressor.
- 2) Drain the oil from the replacement compressor and refill with the same amount that was drained from the original [20 ml (0.7 US fl oz, 0.7 Imp fl oz) minimum]. Always use ZXL200PG for the replacement oil.