

2. Propeller Shaft

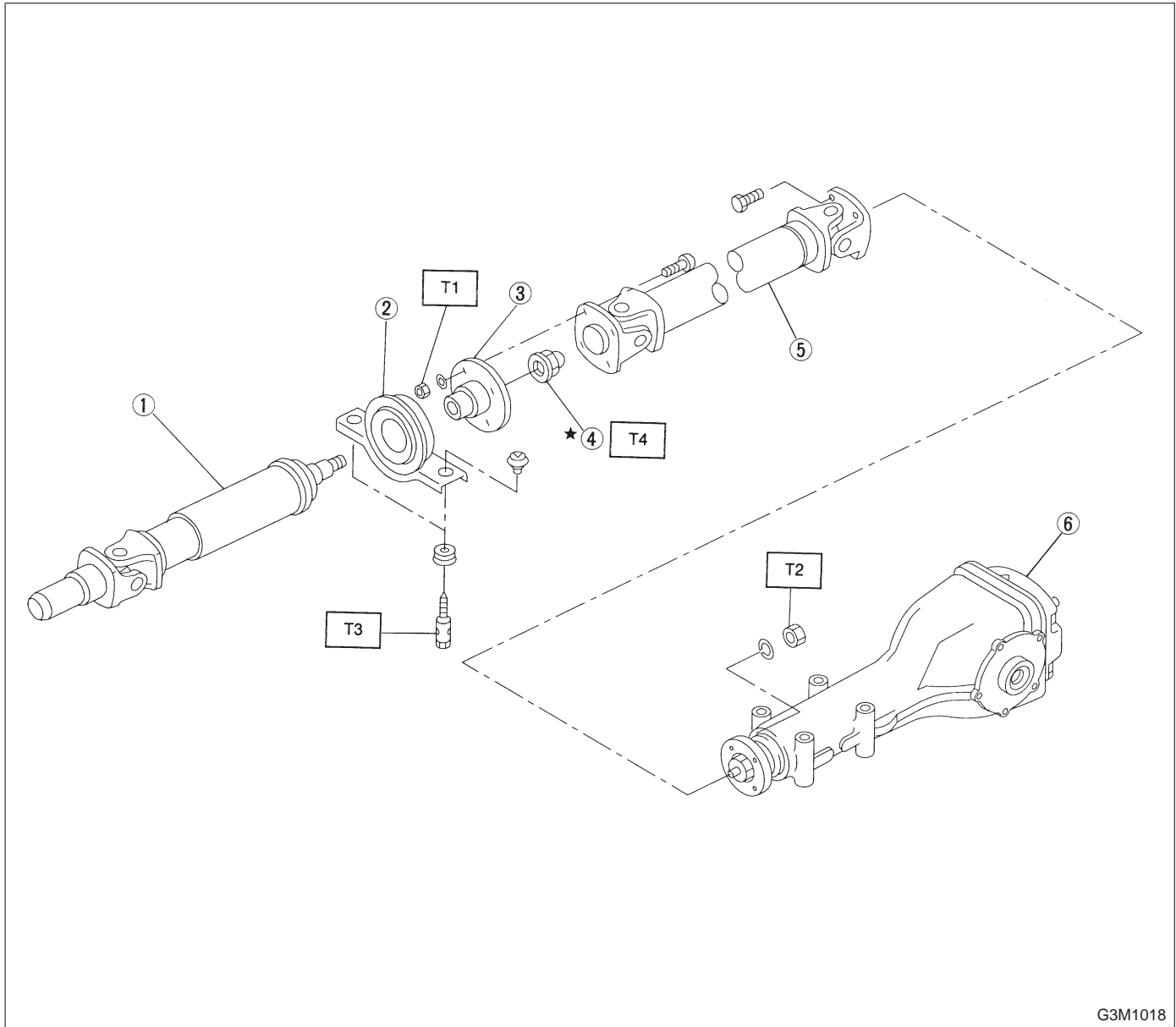

G3M1018

- ① Front propeller shaft
- ② Center bearing
- ③ Companion flange
- ④ Stake nut
- ⑤ Rear propeller shaft
- ⑥ Rear differential

---

**Tightening torque: N·m (kg·m, ft·lb)**

**T1: 27.9±4.4 (2.85±0.45, 20.6±3.3)**

**T2: 31±8 (3.2±0.8, 23.1±5.8)**

**T3: 52±5 (5.3±0.5, 38.3±3.6)**

**T4: 270±25 (27.5±2.5, 199±18)**

---