

3. Transmission Case

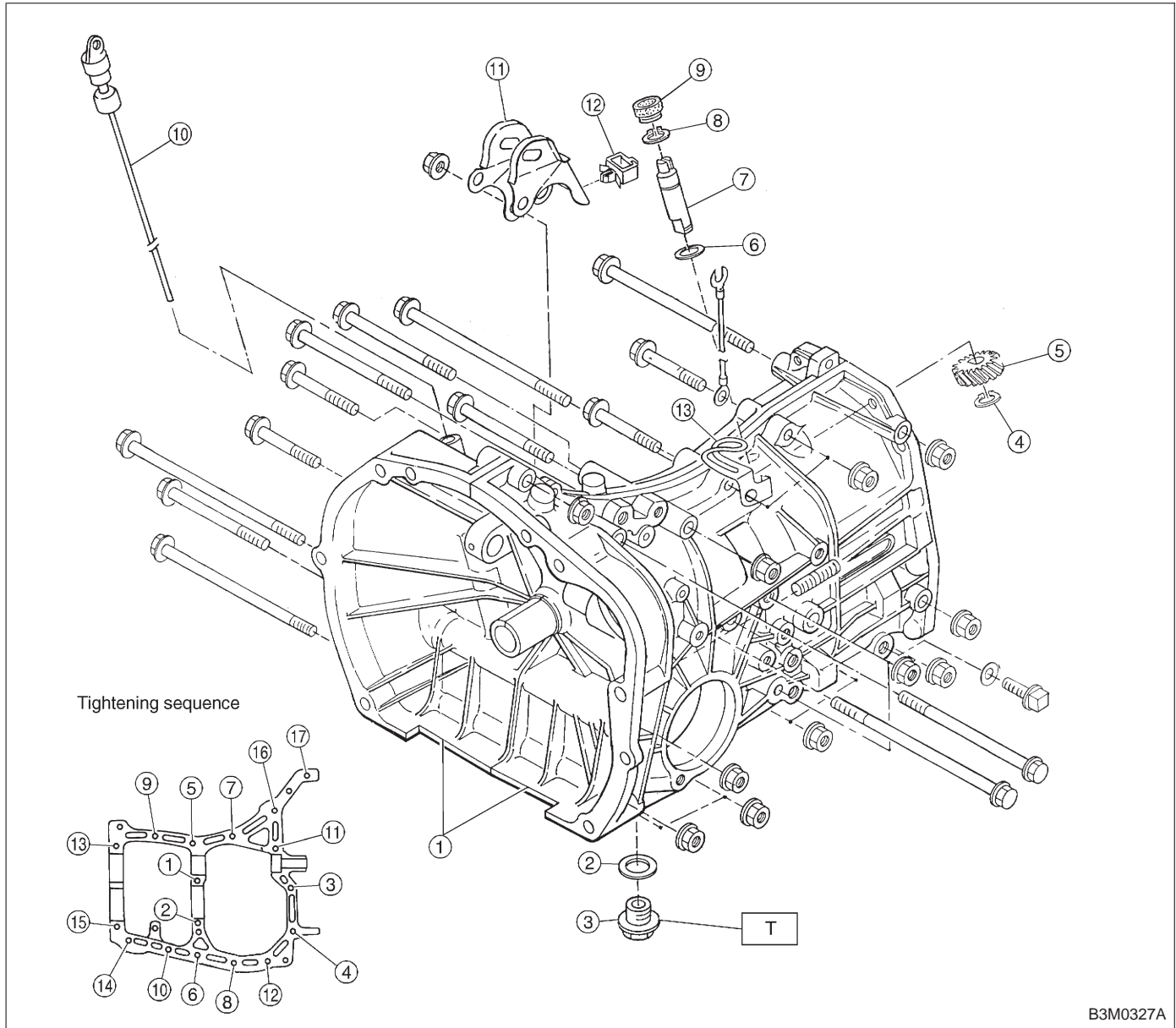

B3M0327A

- ① Transmission case ASSY
- ② Gasket
- ③ Drain plug
- ④ Snap ring (Outer)
- ⑤ Speedometer driven gear
- ⑥ Washer
- ⑦ Speedometer shaft
- ⑧ Snap ring (Outer)
- ⑨ Oil seal
- ⑩ Oil level gauge
- ⑪ Pitching stopper bracket
- ⑫ Clamp
- ⑬ Clip

Tightening torque: N·m (kg·m, ft·lb)
T: 44±3 (4.5±0.3, 32.5±2.2)

Size	All models	Torque
8 mm bolt	⑤ — ⑮	25±2 N·m (2.5±0.2 kg·m, 18.1±1.4 ft·lb)
10 mm bolt	① — ④ ⑯ — ⑰	39±2 N·m (4.0±0.2 kg·m, 28.9±1.4 ft·lb)