

1. Supplemental Restraint System "Airbag"

Airbag system wiring harness is routed near the ABS sensor, ABS control module and hydraulic control unit.

CAUTION:

- All Airbag system wiring harness and connectors are colored yellow. Do not use electrical test equipment on these circuit.
- Be careful not to damage Airbag system wiring harness when servicing the ABS sensor, ABS control module and hydraulic control unit.

2. Pre-inspection

Before performing diagnostics, check the following items which might affect ABS problems:

A: MECHANICAL INSPECTION

1. POWER SUPPLY

1) Measure battery voltage and specific gravity of electrolyte.

Standard voltage: 12 V, or more

Specific gravity: Above 1.260

2) Check the condition of the main and other fuses, and harnesses and connectors. Also check for proper grounding.

2. BRAKE FLUID

- 1) Check brake fluid level.
- 2) Check brake fluid leakage.

3. BRAKE DRAG

Check brake drag. < Ref. to 4-4 [K100].☆1 >

4. BRAKE PAD AND ROTOR

Check brake pad and rotor. < Ref. to 4-4 [K100].☆1 >

5. TIRE SPECIFICATIONS, TIRE WEAR AND AIR PRESSURE

Check tire specifications, tire wear and air pressure. < Ref. to 4-2 [S1A1], [S1A2].☆1 >

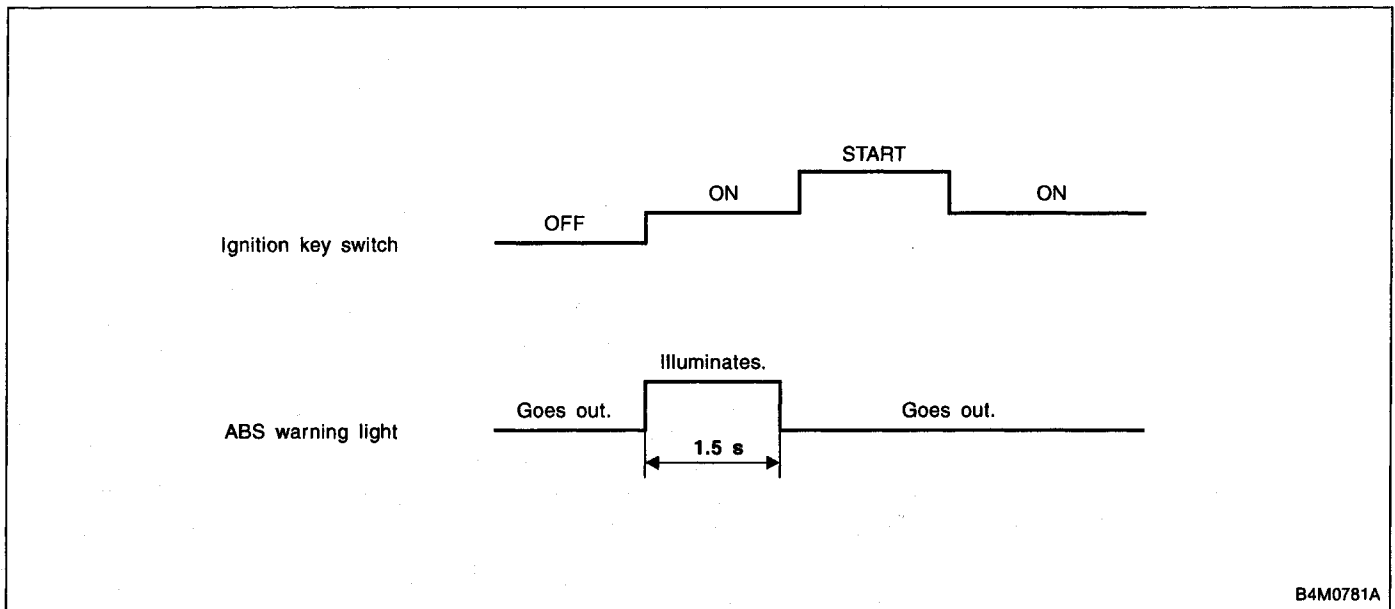
B: ELECTRICAL INSPECTION**1. WARNING LIGHT ILLUMINATION PATTERN**

1) When the ABS warning light does not illuminate in accordance with this illumination pattern, there must be an electrical malfunction.

2) When the ABS warning light remains constantly OFF, repair the ABS warning light circuit or diagnosis circuit.
<Ref. to 4-4d [T7A0].☆10>

NOTE:

Even though the ABS warning light does not go out 1.5 seconds after it illuminates, the ABS system operates normally when the warning light goes out while driving at approximately 12 km/h (7 MPH). However, the Anti-lock brakes do not work while the ABS warning light is illuminated.