

- 8) Do not allow water or oil to come in contact with the connector terminals. Do not touch the connector terminals.
- 9) When connecting or disconnecting airbag connector, make sure ignition switch is OFF.

2. Inspection and Replacement Standards

1. VEHICLES WHICH BECOME INVOLVED IN A COLLISION

If the vehicle equipped with an SRS airbag system is damaged in a collision, the airbag system parts must be checked and replaced in accordance with the following standards:

After faulty parts are replaced, the warning light operation must be checked.

- When the ignition switch is turned ON, it lights up for about 7 seconds and then it goes out for at least 30 seconds.
- The trouble code stored in memory must be erased after the check.

2. AIRBAG MODULE (DRIVER AND PASSENGER)

Inspection standard:

- The vehicle damaged in a collision (regardless of whether or not airbag is deployed).
- The designated trouble code is output during self-diagnosis. (Refer to "Diagnostics" Section.)

Replacement standard:

- Airbag is deployed.
- The pad surface is scratched or cracked.
- Harness and/or connector is deformed or cracked, their circuits are broken, lead wire is exposed, etc.
- Mounting bracket is cracked or deformed.
- The module surface is fouled with foreign matter. (grease, oil, water, cleaning solvent, etc.)
- Airbag module dropped to the floor/ground.
- Airbag module determined as faulty during self-diagnosis.

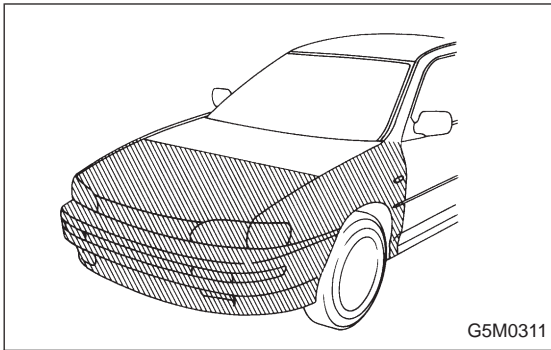

3. FRONT SENSOR

Inspection standard:

- Check the front section (Refer to shaded area of vehicle in figure) for damage, regardless of whether or not airbag is deployed.
- Check whether or not the designated trouble code is output during self-diagnosis. (Refer to "Diagnostics" Section.)

Replacement standard:

- Bracket is deformed.
- Housing is cracked or deformed.
- The label (that identifies the manufacturing number) is peeled or deteriorated.
- Harness circuit is broken, lead wire is exposed, corrugated tube is cracked, etc.
- Front sensor determined as faulty as a result of Diagnostics.
- Airbag is deployed.
- Front sensor dropped to the floor/ground.

4. MAIN HARNESS

Inspection standard:

- A vehicle damaged in a collision (regardless of whether or not airbag is deployed).
- The designated trouble code is output during self-diagnosis. (Refer to "Diagnostics" Section.)

Replacement standard:

- Harness circuit is broken, lead wire is exposed, corrugated tube is cracked, etc.
- Connector is scratched or cracked.
- The designated trouble code is output during self-diagnosis.

5. AIRBAG CONTROL MODULE

Inspection standard:

- A vehicle damaged in a collision (regardless of whether or not airbag is deployed).
- The designated trouble code is output during self-diagnosis. (Refer to "Diagnostics" Section.)

Replacement standard:

- Control module is cracked or deformed.
- Mounting bracket is cracked or deformed.
- Connector is scratched or cracked.
- Control module dropped to the floor/ground.
- Control module determined as faulty during diagnostics.
- Airbag is deployed.

6. COMBINATION SWITCH**Inspection standard:**

- A vehicle damaged in a collision (regardless of whether or not airbag is deployed).
- The designated trouble code is output during self-diagnosis. (Refer to "Diagnostics" Section.)

Replacement standard:

- Combination switch or steering roll connector is deformed or cracked.

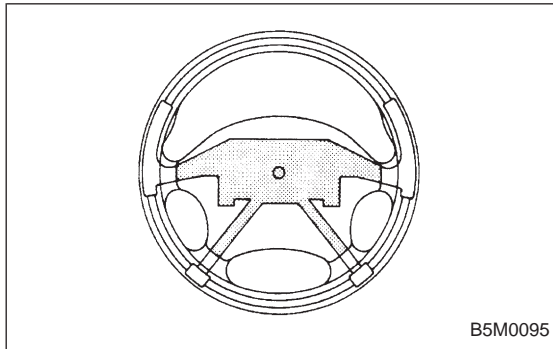
**7. STEERING WHEEL****Inspection standard:**

- A vehicle damaged in a collision (regardless of whether or not airbag is deployed).

Replacement standard:

- Check steering wheel insert for cracks or deformities.
- Check to ensure that new airbag module is properly installed in steering wheel.
- After installing airbag module, check to ensure that it is free of interference with steering wheel and that clearance between the two is equal at all points.

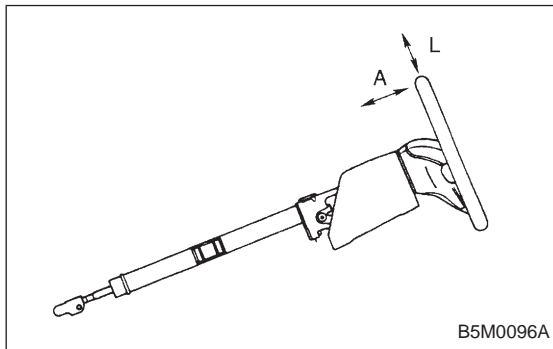
**8. STEERING COLUMN ASSEMBLY****Inspection standard:**

- A vehicle damaged in a collision (regardless of whether or not airbag is deployed).

Replacement standard:

- Check steering wheel free play in axial and radial directions.

Specifications:

Axial free play A
 Less than ± 6 mm (0.24 in)

Radial free play L
 Less than ± 7 mm (0.28 in)

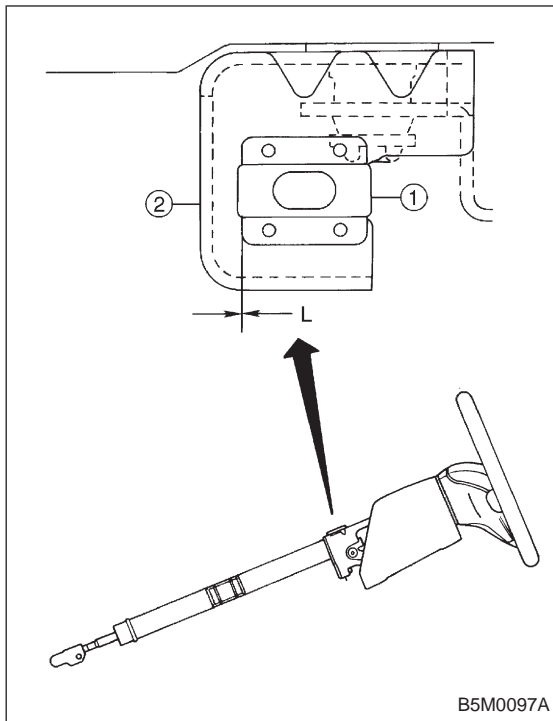

- Check to ensure that clearance between capsule ① (at steering column) and cutout portion of column bracket ② on steering column upper side is within specifications.

Clearance between capsule and cutout portion of column bracket: L

Less than 0.5 mm (0.020 in)