

6. Diagnostic Chart for On-board Diagnostic System

A: BASIC DIAGNOSTICS PROCEDURE

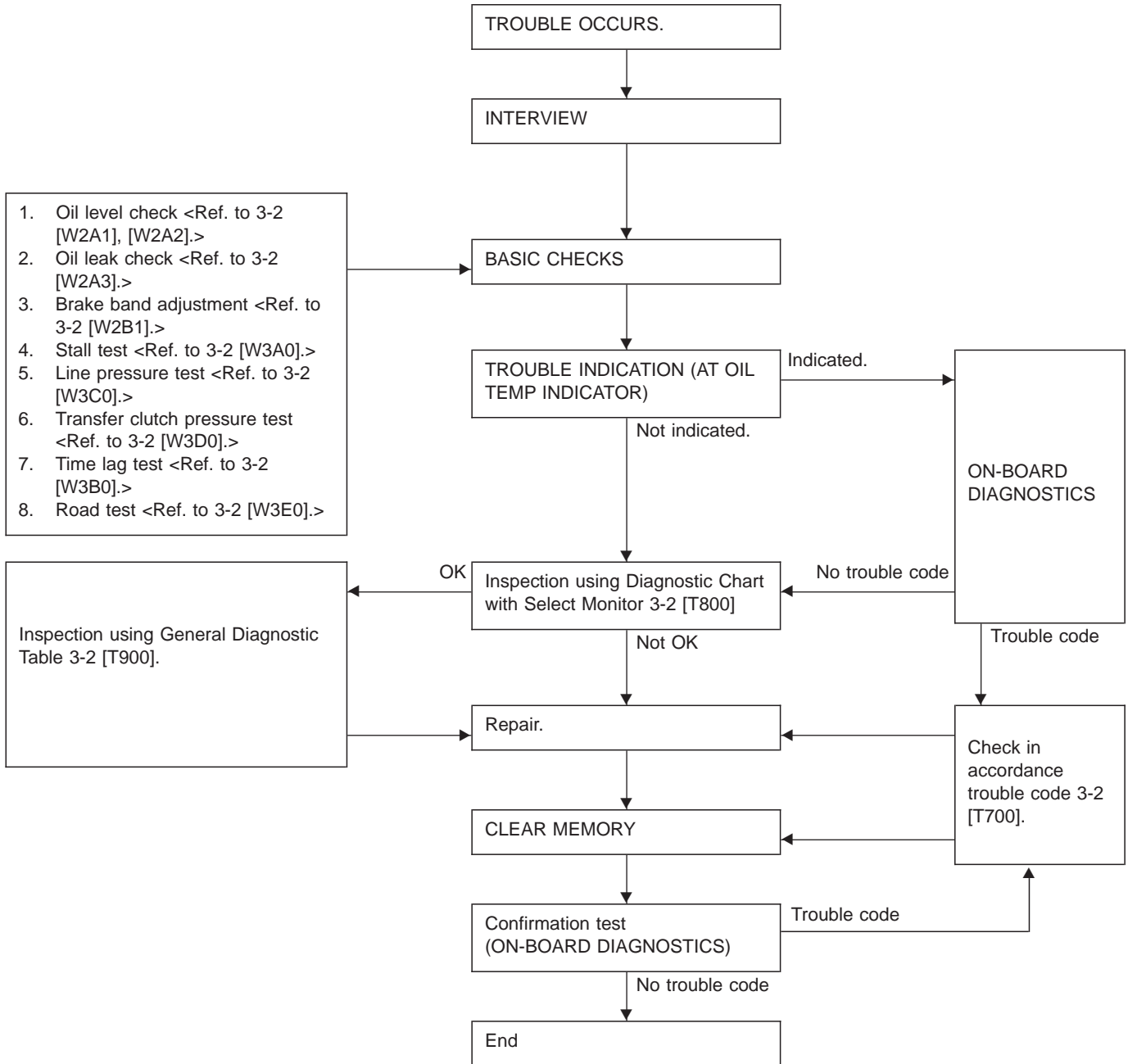

B: ABNORMAL DISPLAY ON AT OIL TEMP INDICATOR

When any on-board diagnostic item is malfunctioning, the display on the AT OIL TEMP indicator blinks immediately after the engine starts.

The malfunctioning part or unit can be determined by a trouble code during on-board diagnostic operation. Problems which occurred previously can also be identified through the memory function.

If the AT OIL TEMP indicator does not show a problem (although a problem is occurring), the problem can be determined by checking the performance characteristics of each sensor using the select monitor.

Indicator signal is as shown in the figure.

WARNING:

Warning can be noticed only when the engine is initially started.

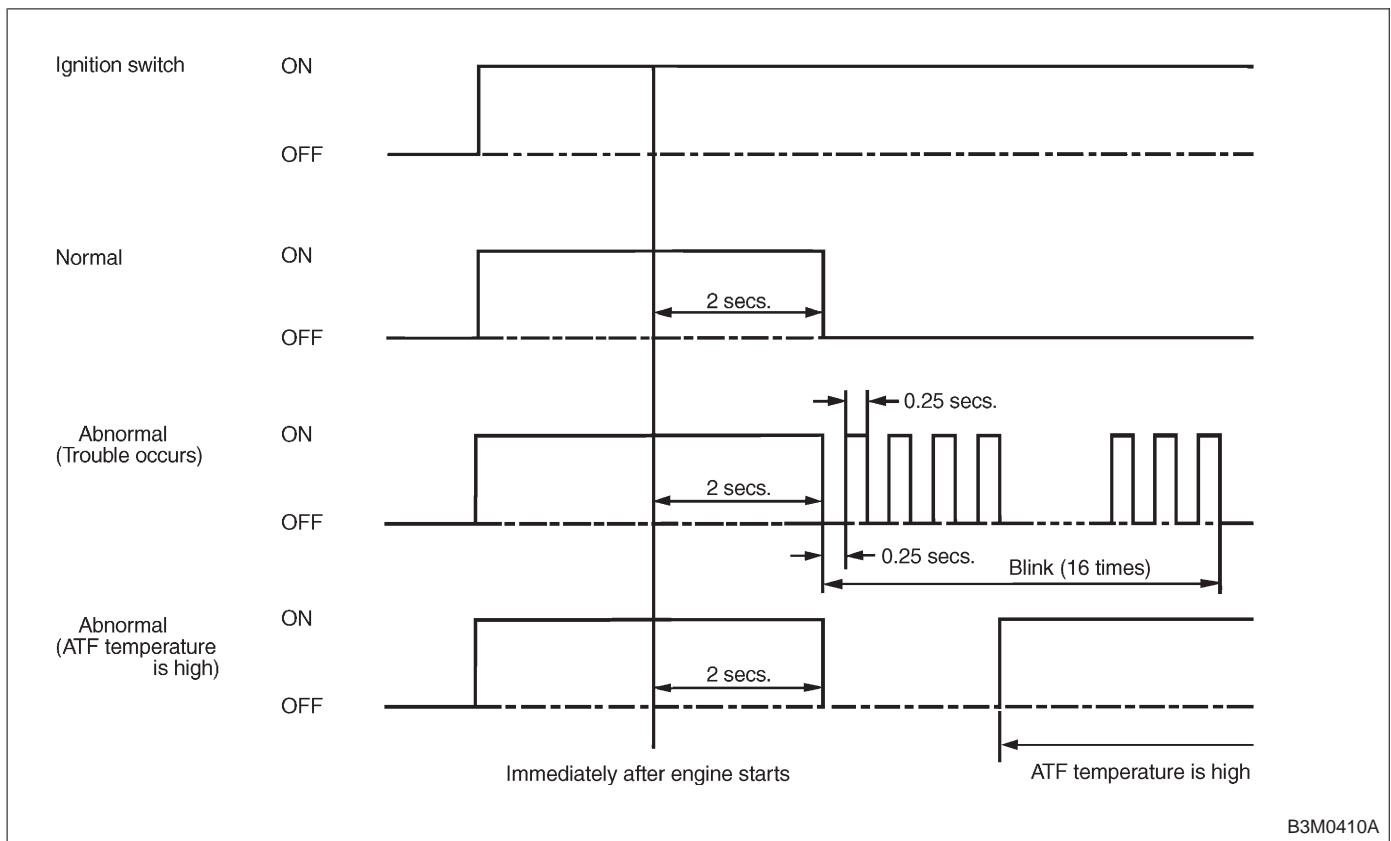

C: ON-BOARD DIAGNOSTICS

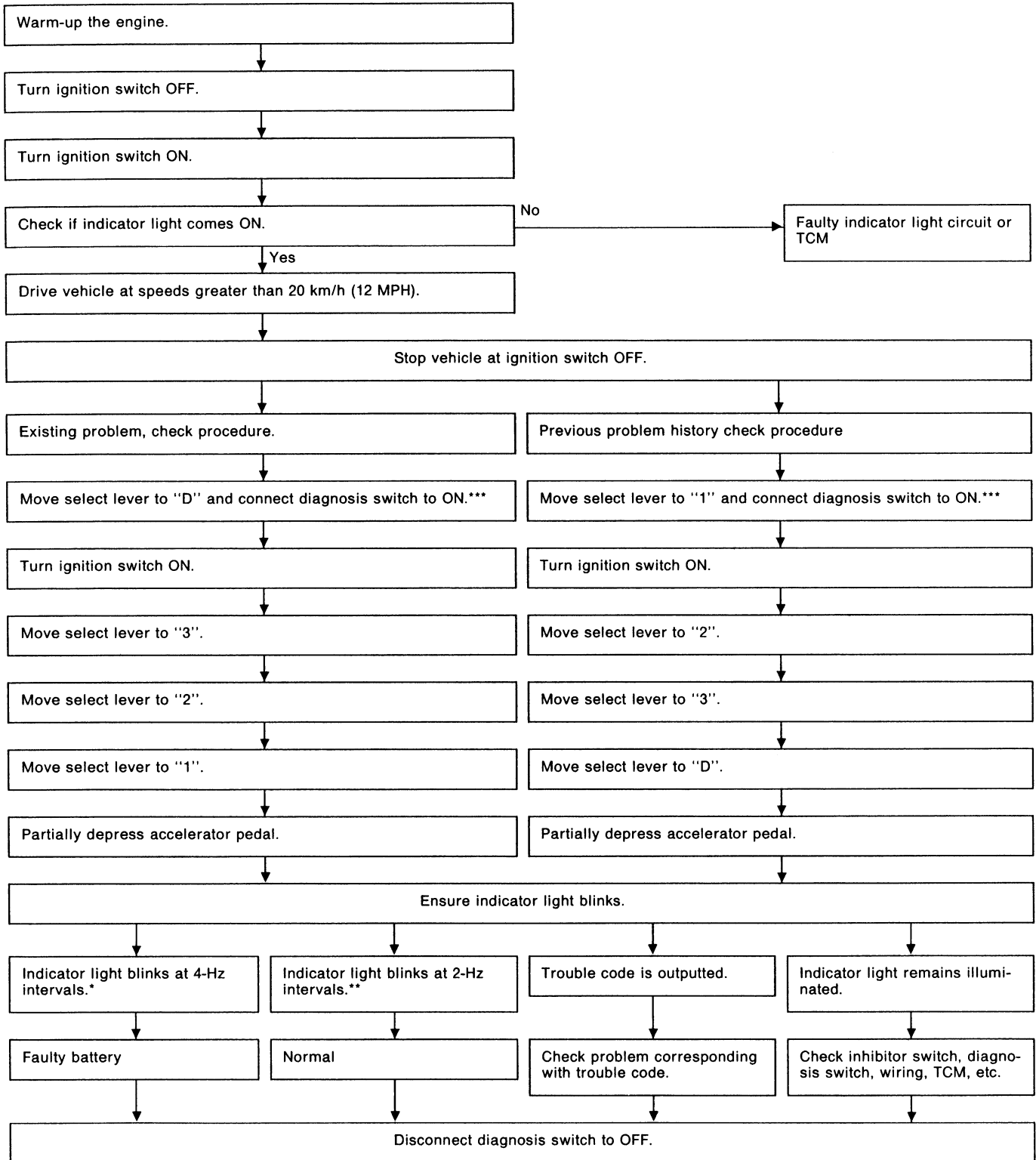

* : Blinks every 0.125 (1/8) seconds (until ignition switch is turned OFF).

** : Blinks every 0.25 (1/4) seconds (until ignition switch is turned OFF).

*** : Plug in diagnosis terminal to diagnosis connector No. 5 located below instrument lower cover.

D: LIST OF TROUBLE CODE**1. TROUBLE CODE**

Trouble code	Item	Content of diagnosis	Abbr. (Select monitor)	Page
11	Duty solenoid A	Detects open or shorted drive circuit, as well as valve seizure.	PLDTY	16
12	Duty solenoid B	Detects open or shorted drive circuit, as well as valve seizure.	LUPTY	20
13	Shift solenoid 3	Detects open or shorted drive circuit, as well as valve seizure.	OVR	24
14	Shift solenoid 2	Detects open or shorted drive circuit, as well as valve seizure.	SFT2	26
15	Shift solenoid 1	Detects open or shorted drive circuit, as well as valve seizure.	SFT1	28
21	ATF temperature sensor	Detects open or shorted input signal circuit.	ATFT	30
22	Mass air flow signal	Detects open or shorted input signal circuit.	AFM	33
23	Engine speed signal	Detects open or shorted input signal circuit.	EREV	35
24	Duty solenoid C	Detects open or shorted drive circuit, as well as valve seizure.	4WPTY	37
25	Torque control signal	Detects open or shorted input signal circuit.	TQ.CT	39
31	Throttle position sensor	Detects open or shorted input signal circuit.	THV	41
32	Vehicle speed sensor 1	Detects open or shorted input signal circuit.	VSP1	44
33	Vehicle speed sensor 2	Detects open or shorted input signal circuit.	VSP2	48

2. HOW TO READ TROUBLE CODE OF INDICATOR LIGHT

The AT OIL TEMP indicator light flashes the code corresponding to the faulty part.

The long segment (1.2 sec on) indicates a “ten”, and the short segment (0.2 sec on) signifies a “one”.

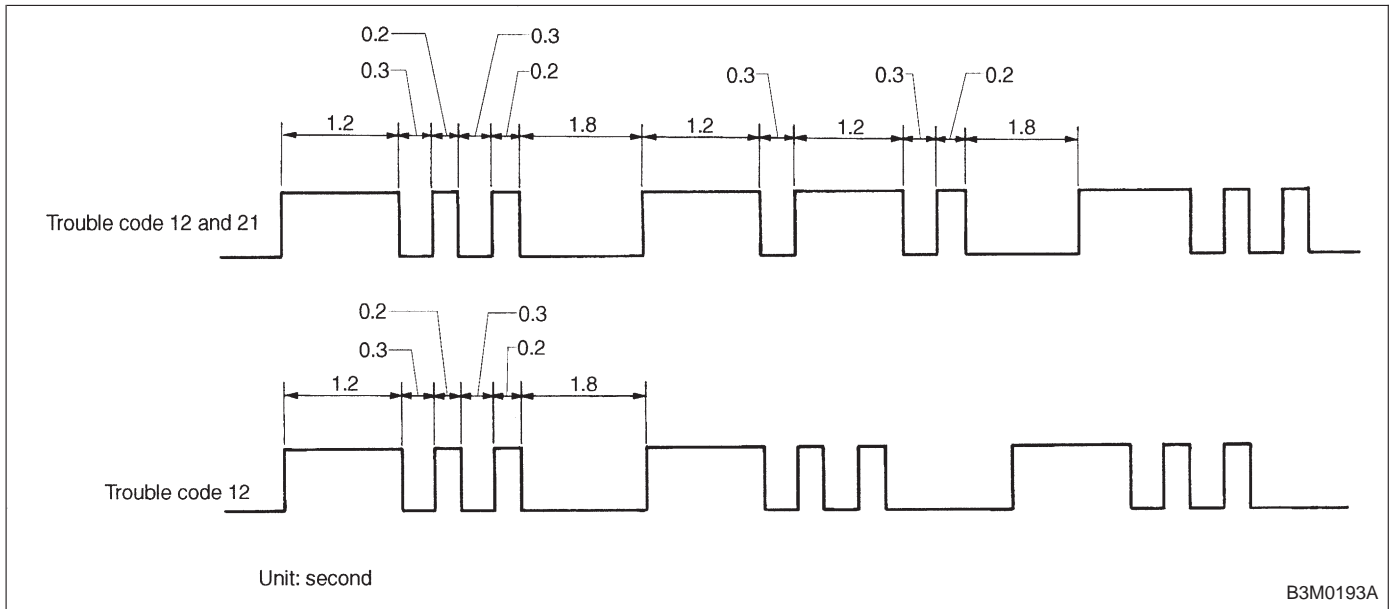

B3M0193A

E: CLEAR MEMORY

Current trouble codes shown on the display are cleared by turning the ignition switch OFF after conducting on-board diagnostic operation. Previous trouble codes, however, cannot be cleared since they are stored in the TCM memory which is operating on the back-up power supply. These trouble codes can be cleared by removing the specified fuse (located under the right lower portion of the instrument panel).

CLEAR MEMORY:

Removal of No. 14 fuse (for at least one minute)

- The No. 14 fuse is located in the line to the memory back-up power supply of the TCM and ABS/TCS control module. Removal of this fuse clears the previous trouble codes stored in the TCM and ABS/TCS control module memory.
- Be sure to remove the No. 14 fuse for at least the specified length of time. Otherwise, trouble codes may not be cleared.