

## 4. Cautions

### A: SUPPLEMENTAL RESTRAINT SYSTEM “AIRBAG”

Airbag system wiring harness is routed near the engine control module (ECM), main relay and fuel pump relay.

#### CAUTION:

- All Airbag system wiring harness and connectors are colored yellow. Do not use electrical test equipment on these circuit.
- Be careful not to damage Airbag system wiring harness when servicing the engine control module (ECM), transmission control module (TCM), main relay and fuel pump relay.

### B: PRECAUTIONS

- 1) Never connect the battery in reverse polarity.
  - The ECM will be destroyed instantly.
  - The fuel injector and other part will be damaged in just a few minutes more.
- 2) Do not disconnect the battery terminals while the engine is running.
  - A large counter electromotive force will be generated in the alternator, and this voltage may damage electronic parts such as ECM, etc.
- 3) Before disconnecting the connectors of each sensor and the ECM, be sure to turn OFF the ignition switch.
- 4) Before removing ECM from the located position, disconnect two cables on battery.
  - Otherwise, the ECM may be damaged.
- 5) The connectors to each sensor in the engine compartment and the harness connectors on the engine side and body side are all designed to be waterproof. However, it is still necessary to take care not to allow water to get into the connectors when washing the vehicle, or when servicing the vehicle on a rainy day.

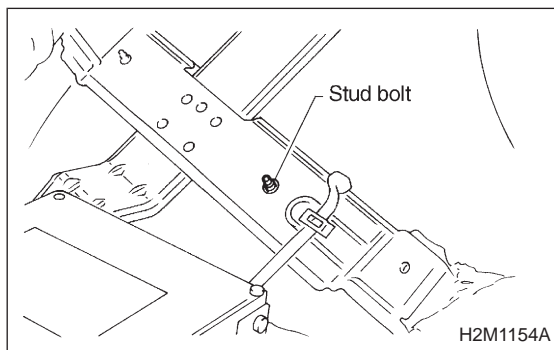

- 6) Use ECM mounting stud bolts at the body head grounding point when measuring voltage and resistance inside the passenger compartment.

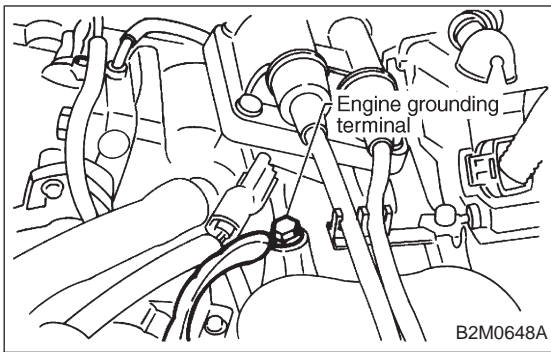

7) Use engine grounding terminal or engine proper as the grounding point to the body when measuring voltage and resistance in the engine compartment.

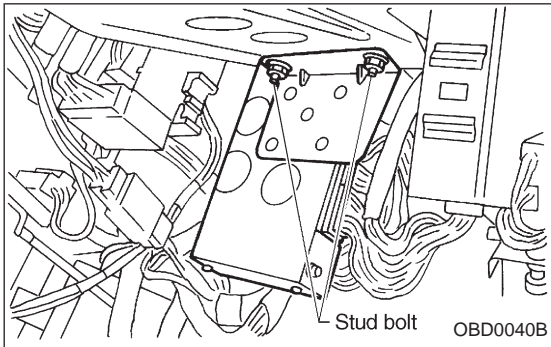

8) Use TCM mounting stud bolts at the body head grounding point when measuring voltage and resistance inside the passenger compartment.

9) Every MFI-related part is a precision part. Do not drop them.

10) Observe the following cautions when installing a radio in MFI equipped models.

**CAUTION:**

- The antenna must be kept as far apart as possible from the control unit.

(The ECM is located under the steering column, inside of the instrument panel lower trim panel.)

- The antenna feeder must be placed as far apart as possible from the ECM and MFI harness.

- Carefully adjust the antenna for correct matching.

- When mounting a large power type radio, pay special attention to the three items above mentioned.

- Incorrect installation of the radio may affect the operation of the ECM.

11) Before disconnecting the fuel hose, disconnect the fuel pump connector and crank the engine for more than five seconds to release pressure in the fuel system. If engine starts during this operation, run it until it stops.

12) Problems in the electronic-controlled automatic transmission may be caused by failure of the engine, the electronic control system, the transmission proper, or by a combination of these. These three causes must be distinguished clearly when performing diagnostics.

13) Diagnostics should be conducted by rotating with simple, easy operations and proceeding to complicated, difficult operations. The most important thing in diagnostics is to understand the customer's complaint, and distinguish between the three causes.

14) In AT vehicles, do not continue the stall for more than five seconds at a time (from closed throttle, fully open throttle to stall engine speed).

15) On ABS or ABS/TCS vehicle, when performing driving test in jacked-up or lifted-up position, sometimes the warning light may be lit, but this is not a malfunction of the system. The reason for this is the speed difference between the front and rear wheels. After diagnosis of engine control system, perform the ABS or ABS/TCS memory clearance procedure of self-diagnosis system. <Ref. to 4-4b [T6D2] or [T9K0], or 4-4c [T6D2] or [T9J0], or 4-4d [T6D2] or [T9J0].>

### **C: PRE-INSPECTION**

Before performing diagnostics, check the following items which might affect engine problems:

#### **1. POWER SUPPLY**

1) Measure battery voltage and specific gravity of electrolyte.

**Standard voltage: 12 V**

**Specific gravity: Above 1.260**

2) Check the condition of the main and other fuses, and harnesses and connectors. Also check for proper grounding.

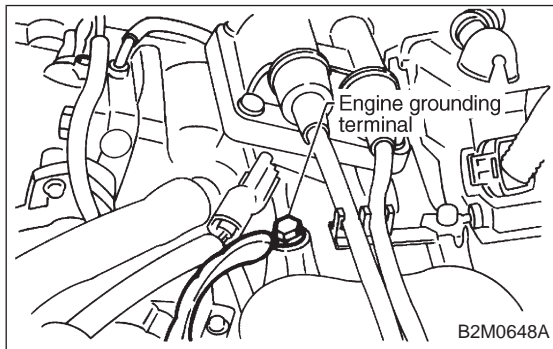

#### **2. ENGINE GROUNDING**

Make sure the engine grounding terminal is properly connected to the engine.