

1. Starter Interlock System (MT Model)

A: DIAGNOSTICS PROCEDURE

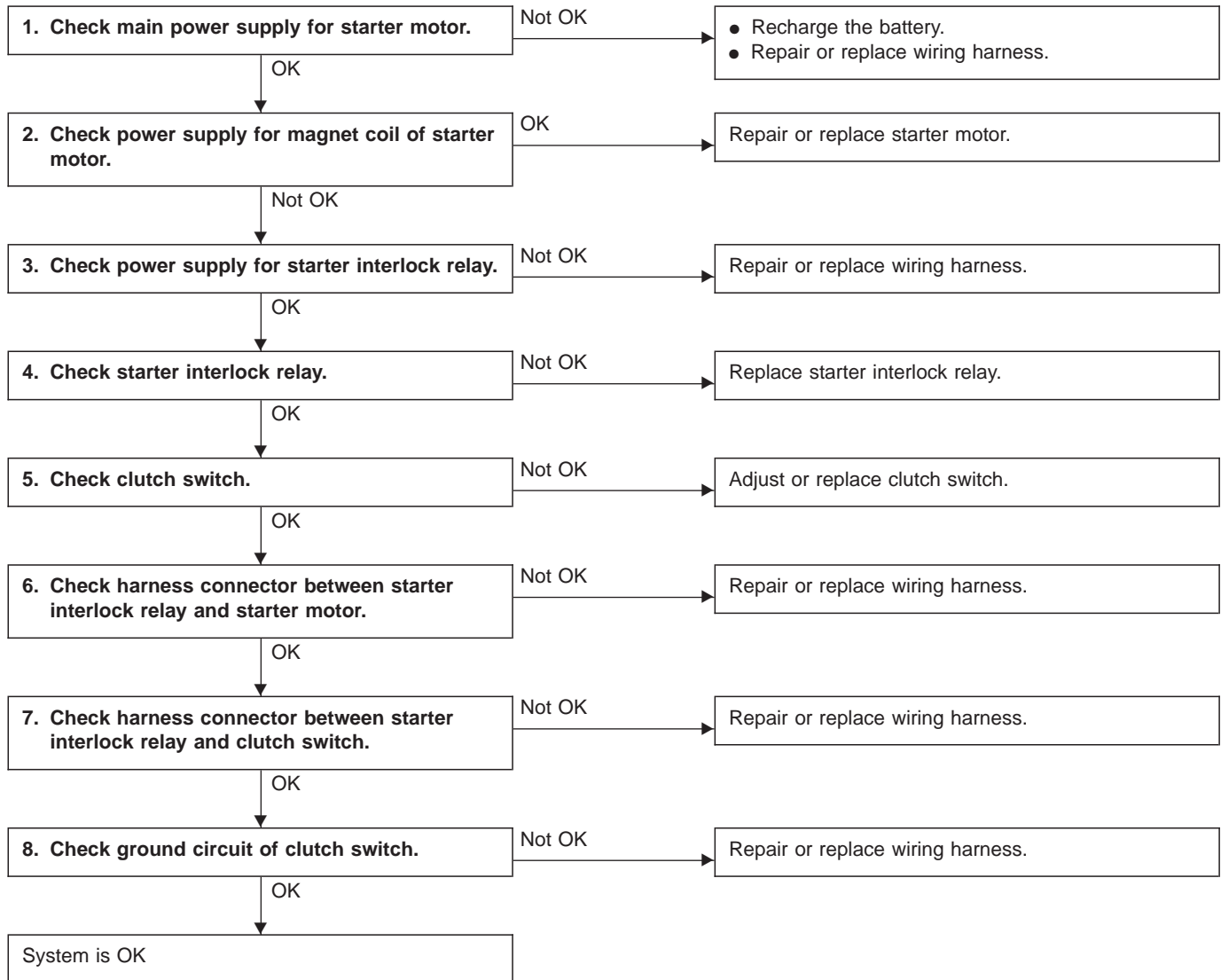

1. Starter Interlock System (MT Model)

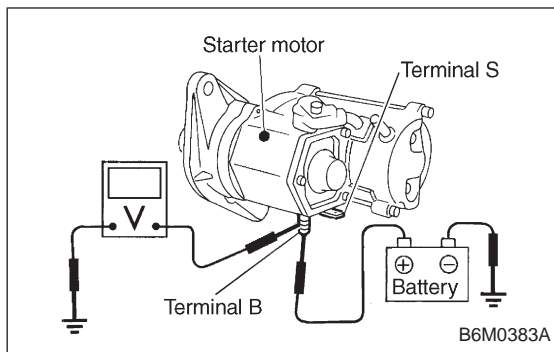

1. CHECK MAIN POWER SUPPLY FOR STARTER MOTOR.

Measure voltage between starter motor terminal B and body.

Connector & terminal / Specified voltage:
Terminal B — Body / 10 V, or more

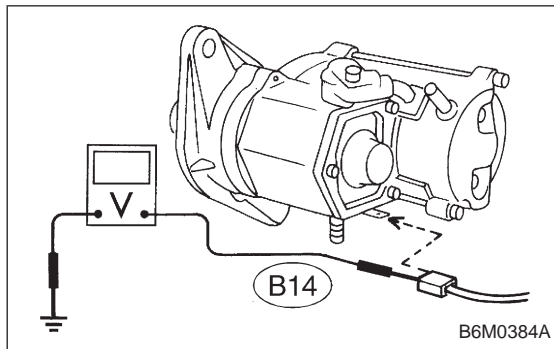

2. CHECK POWER SUPPLY FOR MAGNET COIL OF STARTER MOTOR.

- 1) Disconnect all connectors from starter motor.
- 2) Turn ignition switch to ST (START).
- 3) Depress clutch pedal.
- 4) Measure voltage between starter motor terminal S connector and body.

Connector & terminal / Specified voltage:
(B14) Terminal S — Body / 10 V, or more

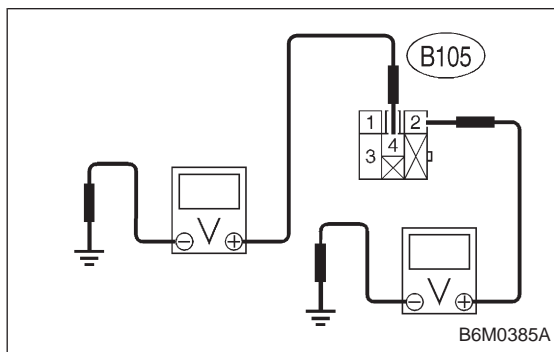

3. CHECK POWER SUPPLY FOR STARTER INTERLOCK RELAY.

- 1) Disconnect all connectors from starter motor.
- 2) Disconnect connector of starter interlock relay.
- 3) Turn ignition switch to ST (START).
- 4) Measure voltage between starter interlock relay connector and body.

Connector & terminal / Specified voltage:
(B105) No. 2 — Body / 10 V, or more
(B105) No. 4 — Body / 10 V, or more

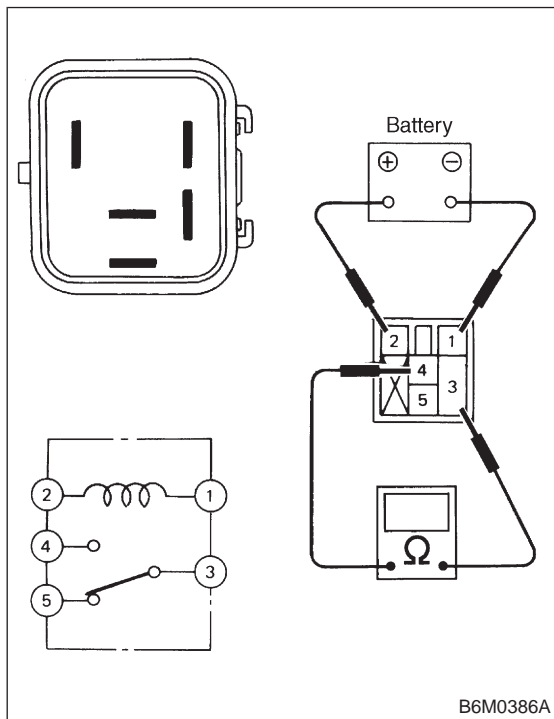

4. CHECK STARTER INTERLOCK RELAY.

- 1) Disconnect connector of starter interlock relay.
- 2) Connect battery to terminal No. 2 and ground terminal No. 1.
- 3) Check continuity between terminals as indicated in table below:

When current flows.	Between terminals No. 3 and No. 4	Continuity exists.
When current does not flow.	Between terminals No. 3 and No. 4	Continuity does not exist.
	Between terminals No. 1 and No. 2	Continuity exists.

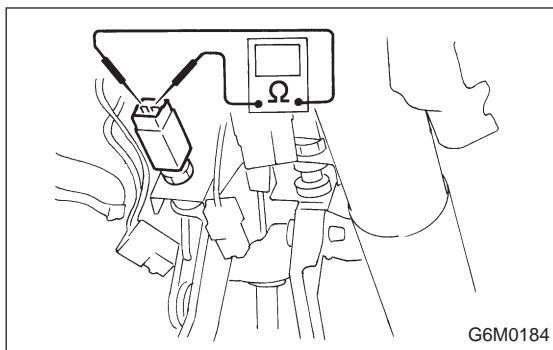
**5. CHECK CLUTCH SWITCH.**

- 1) Disconnect connector of clutch switch.
- 2) Check continuity between terminals when clutch pedal is depressed/released.

Terminals / Specified resistance:

No. 1 — No. 2 / 10 Ω, max.

**(Without pedal depressing.)
/ 1 MΩ, min. (Pedal depressing.)**

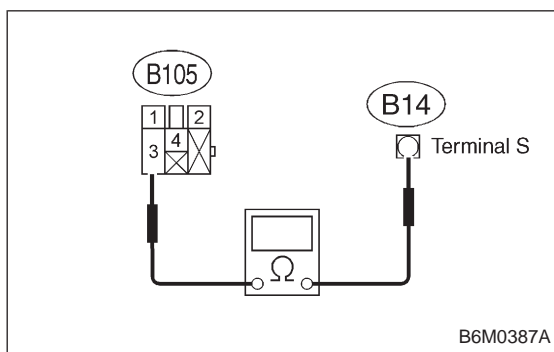
**6. CHECK HARNESS CONNECTOR BETWEEN STARTER INTERLOCK RELAY AND STARTER MOTOR.**

- 1) Disconnect connectors of starter interlock relay and starter motor.
- 2) Measure resistance of harness connector between starter interlock relay and starter motor.

Connector & terminal / Specified resistance:

(B105) No. 3 — (B14) terminal S / 10 Ω, max.

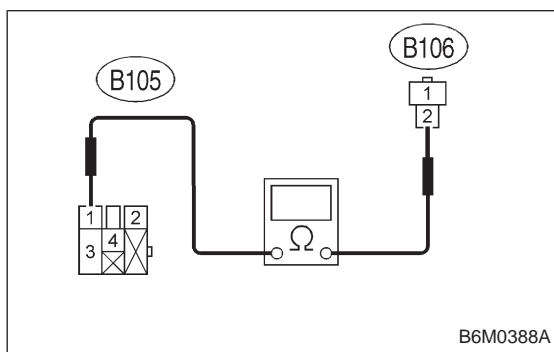
**7. CHECK HARNESS CONNECTOR BETWEEN STARTER INTERLOCK RELAY AND CLUTCH SWITCH.**

- 1) Disconnect connectors of starter interlock relay and clutch switch.
- 2) Measure resistance of harness connector between starter interlock relay and clutch switch.

Connector & terminal / Specified resistance:

(B105) No. 1 — (B106) No. 2 / 10 Ω, max.

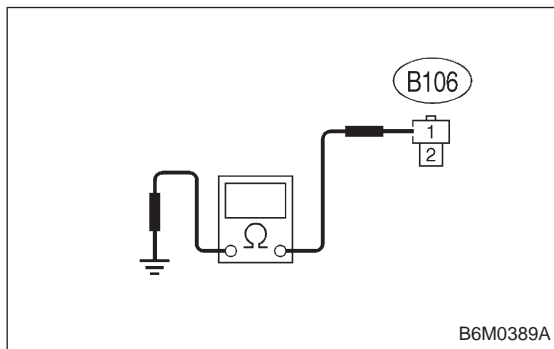
**8. CHECK GROUND CIRCUIT OF CLUTCH SWITCH.**

- 1) Disconnect connector of clutch switch.
- 2) Measure resistance of harness connector between clutch switch and body.

Connector & terminal / Specified resistance:

(B106) No. 1 — Body / 10 Ω, max.