

5. Camshaft

A: REMOVAL

1. RELATED PARTS

1) Remove timing belt, camshaft sprockets and related parts.

<Ref. to 2-3 [W3A0].>

2) Remove valve rocker assembly.

<Ref. to 2-3 [W4A0].>

2. CAMSHAFT LH

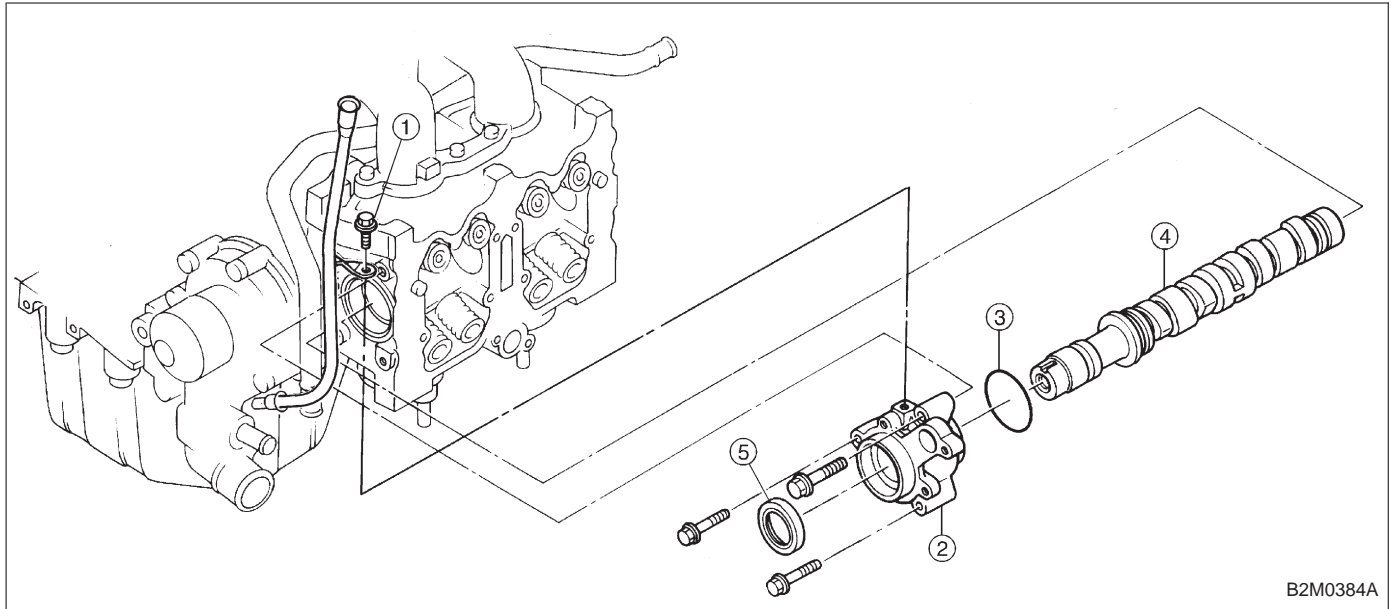

1) Remove oil level gauge guide attaching bolt.

2) Remove camshaft support LH.

CAUTION:

Do not damage the camshaft position sensor.

3) Remove O-ring.

4) Remove camshaft LH.

5) Remove oil seal.

CAUTION:

● **Do not remove oil seal unless necessary.**

● **Do not scratch journal surface when removing oil seal.**

3. CAMSHAFT RH

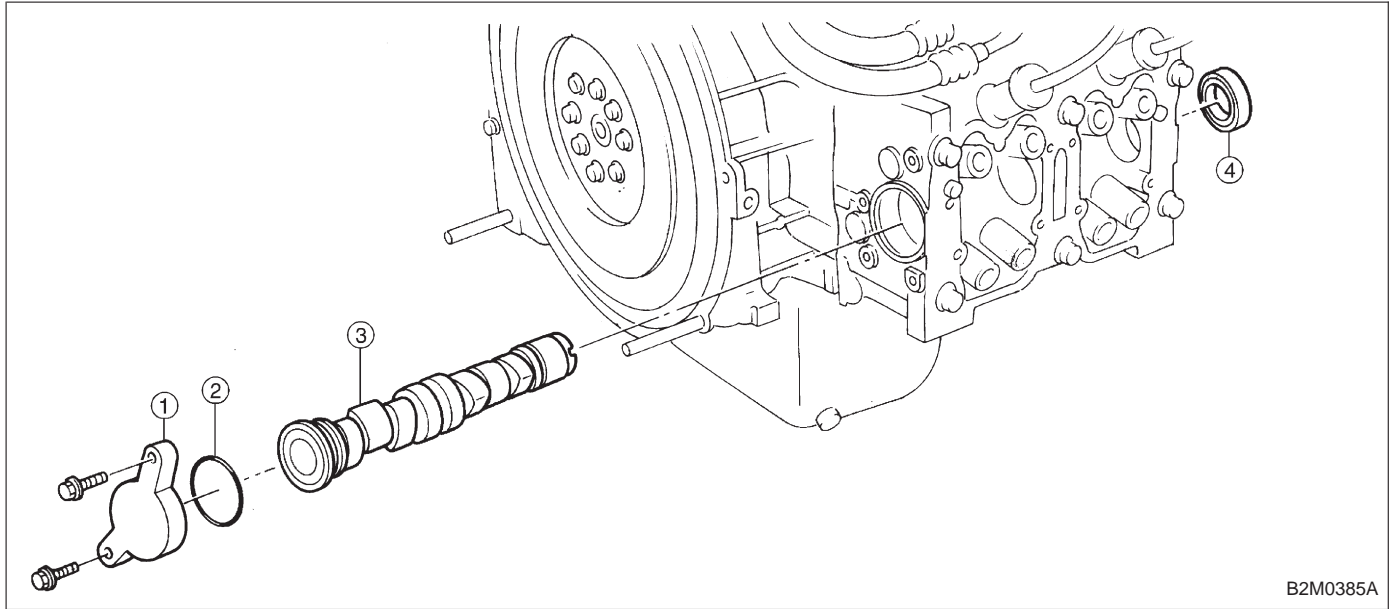

B2M0385A

- 1) Remove camshaft support RH.
- 2) Remove O-ring.
- 3) Remove camshaft.
- 4) Remove oil seal.

CAUTION:

- Do not remove oil seal unless necessary.
- Do not scratch journal surface when removing oil seal.

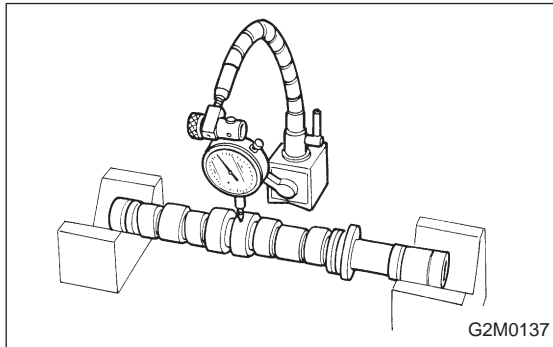

G2M0137

B: INSPECTION**1. CAMSHAFT**

- 1) Measure the bend, and repair or replace if necessary.

Limit:**0.025 mm (0.0010 in)**

- 2) Check journal for damage and wear. Replace if faulty.

- 3) Measure outside diameter of camshaft journal and inside diameter of cylinder head journal, and determine the difference between the two (= oil clearance). If oil clearance exceeds specifications, replace camshaft or cylinder head as necessary.

Unit: mm (in)

Item	Right-hand camshaft	Front	Center	Rear
	Left-hand camshaft	Rear	Center	Front
Clearance at journal	Standard	0.055 — 0.090 (0.0022 — 0.0035)		
	Limit	0.10 (0.0039)		
Camshaft journal O.D.		31.935 — 31.950 (1.2573 — 1.2579)	37.435 — 37.450 (1.4738 — 1.4744)	37.935 — 37.950 (1.4935 — 1.4941)
Journal hole I.D.		32.005 — 32.025 (1.2600 — 1.2608)	37.505 — 37.525 (1.4766 — 1.4774)	38.005 — 38.025 (1.4963 — 1.4970)

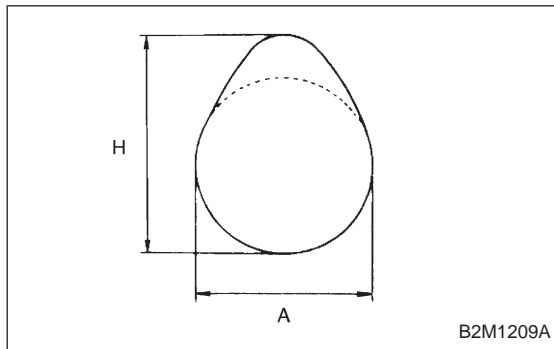

4) Check cam face condition; remove minor faults by grinding with oil stone. Measure the cam height H; replace if the limit has been exceeded.

Cam height: H

Standard

IN: 32.244 — 32.344 mm (1.2694 — 1.2734 in)

EX: 31.964 — 32.064 mm (1.2584 — 1.2624 in)

Limit

IN: 32.094 mm (1.2635 in)

EX: 31.814 mm (1.2525 in)

Cam base circle diameter A:

IN: 27.5 mm (1.083 in)

EX: 27.0 mm (1.063 in)

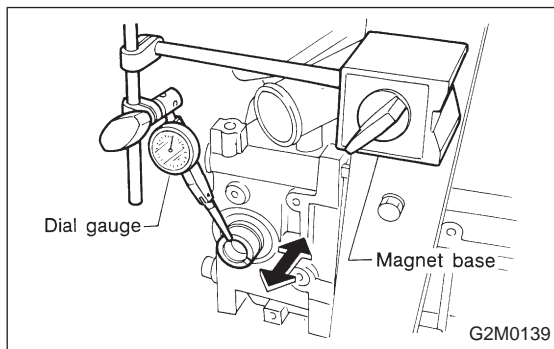

2. CAMSHAFT SUPPORT

Measure the thrust clearance of camshaft with dial gauge. If the clearance exceeds the limit, replace camshaft support.

Standard:

0.030 — 0.260 mm (0.0012 — 0.0102 in)

Limit:

0.35 mm (0.0138 in)

C: INSTALLATION

1. CAMSHAFT LH

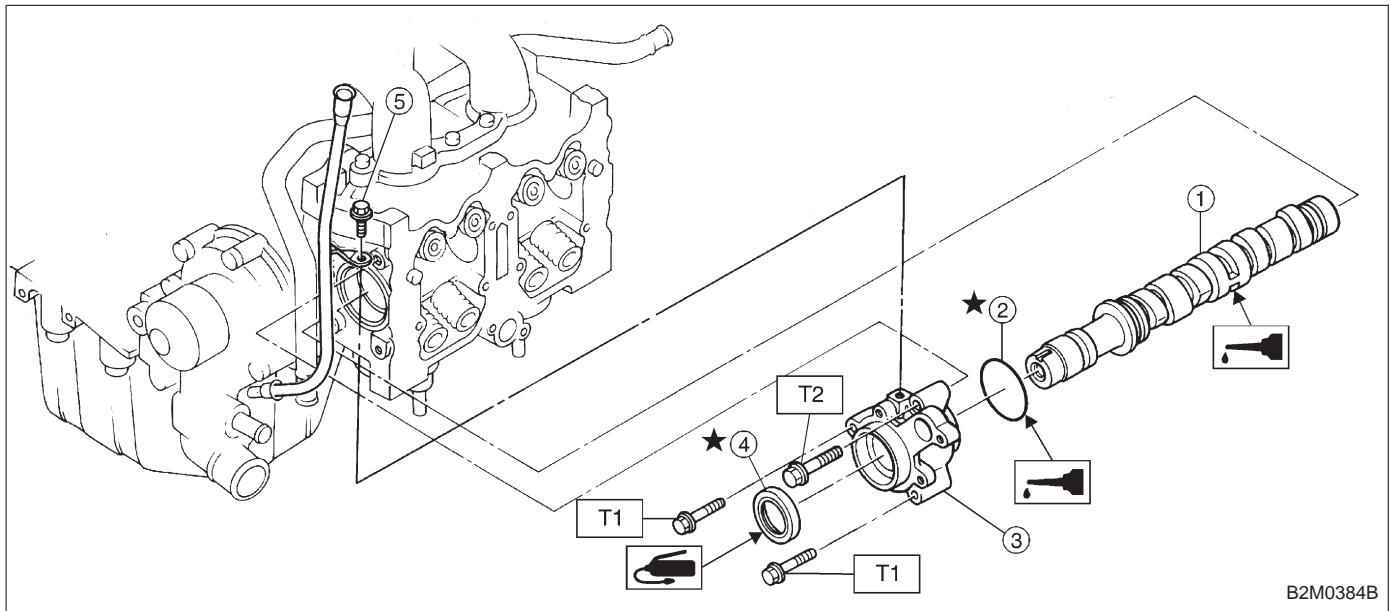

Tightening torque: N·m (kg·m, ft·lb)
T1: 10 (1.0, 7)
T2: 16 (1.6, 12)

- 1) Apply a coat of engine oil to camshaft journals and install camshaft LH.
- 2) Apply a coat of engine oil or grease to O-ring.
- 3) Install O-ring to camshaft support.

CAUTION:

Use a new O-ring.

- 4) Install camshaft support.

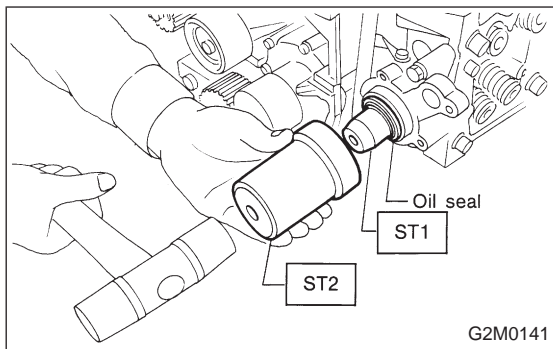

- 5) Apply a coat of grease to oil seal lips and install oil seal on camshaft support by using ST1 and ST2.

CAUTION:

Use a new oil seal.

ST1 499597000 OIL SEAL GUIDE
ST2 499587100 OIL SEAL INSTALLER

- 6) Install oil level gauge guide bolt.

2. CAMSHAFT RH

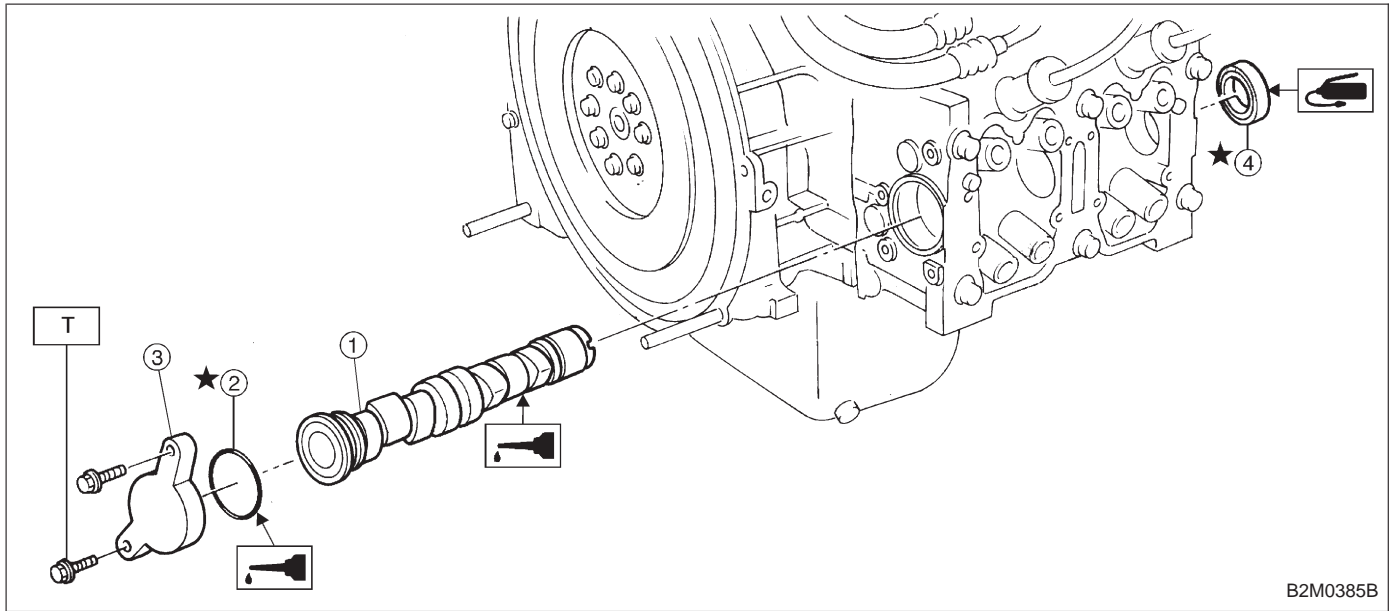

Tightening torque: N·m (kg·m, ft·lb)
T: 16 (1.6, 12)

- 1) Apply a coat of engine oil to camshaft journals and install camshaft RH.
- 2) Apply a coat of engine oil or grease to O-ring.
- 3) Install O-ring to camshaft support.

CAUTION:

Use a new O-ring.

- 4) Install camshaft support.

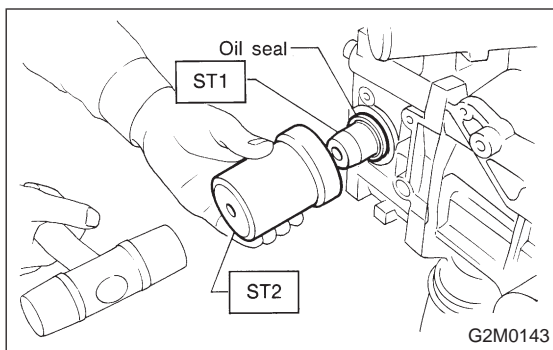

- 5) Install oil seal by using ST1 and ST2.

CAUTION:

Use a new oil seal.

ST1	499597000	OIL SEAL GUIDE
ST2	499587100	OIL SEAL INSTALLER

3. RELATED PARTS

- 1) Install valve rocker assembly.
<Ref. to 2-3 [W4E0].>

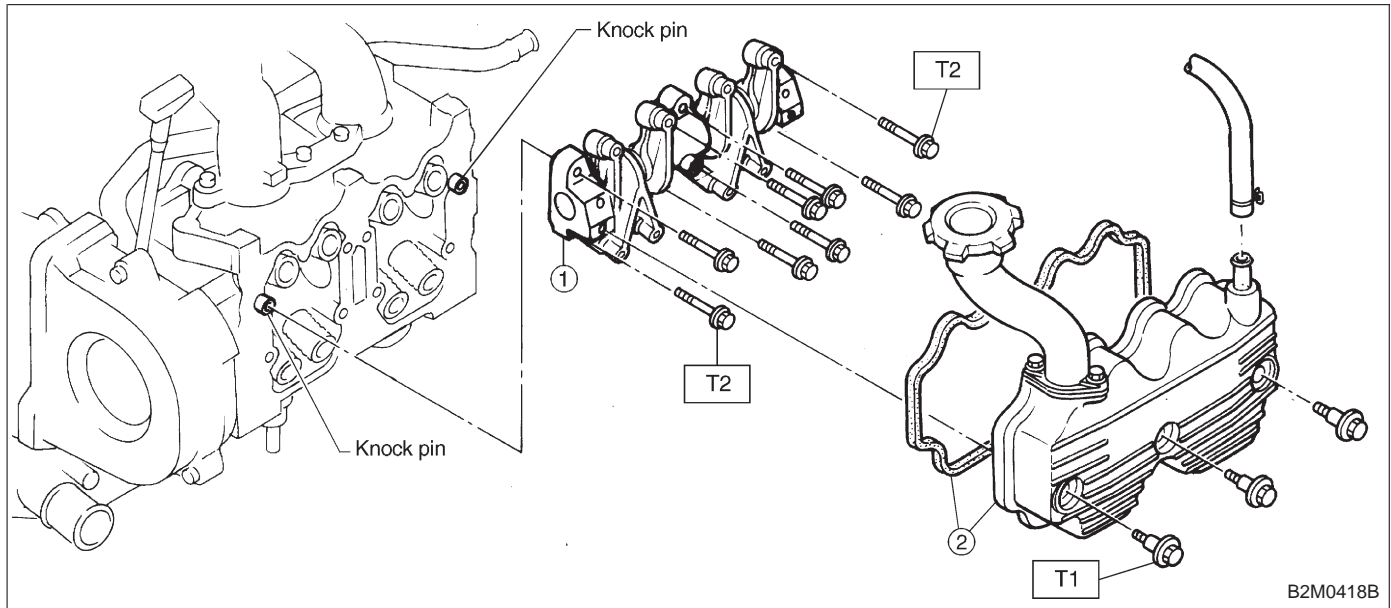

Tightening torque: N·m (kg-m, ft-lb)

T1: 5±1 (0.5±0.1, 3.6±0.7)

T2: 12±1 (1.2±0.1, 8.7±0.7)

- 2) Install timing belt, camshaft sprockets and related parts.
<Ref. to 2-3 [W3C0].>

6. Cylinder Head**A: REMOVAL****1. INTAKE MANIFOLD**

- 1) Release fuel pressure. <Ref. to 2-8 [W1A0].>
- 2) Drain engine coolant. <Ref. to 2-5 [W1A0].>
- 3) Remove intake manifold. <Ref. to 2-7 [W4A0].>
- 4) Remove engine coolant pipe.