

4. Radiator

A: REMOVAL

1) Disconnect battery cables and remove battery from body.

2) Drain engine coolant.

Set container under the vehicle, and remove drain cock from radiator.

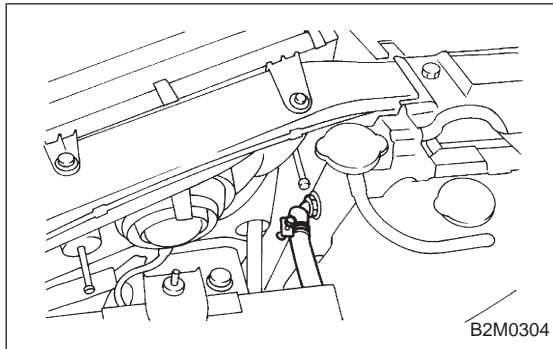

3) Disconnect radiator outlet hose from thermostat cover.

4) Disconnect ATF cooler hoses from radiator. (AT model)

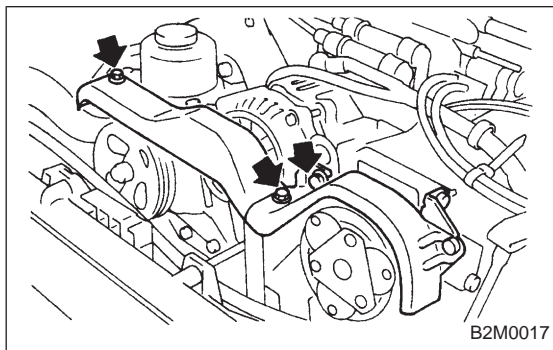

5) Remove V-belt cover.

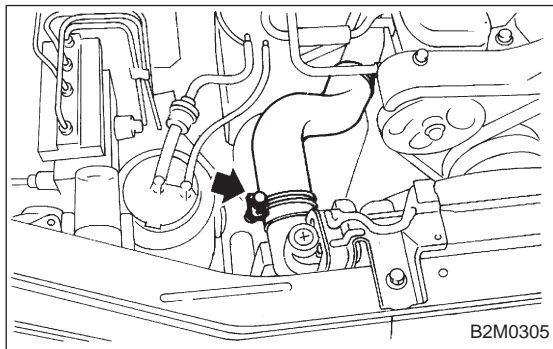

6) Disconnect inlet hose from radiator.

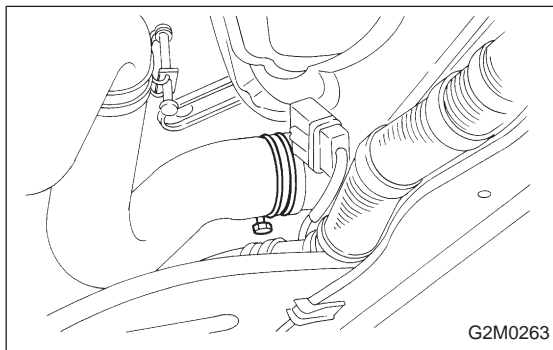

7) Disconnect connectors of radiator main fan and sub fan motor.

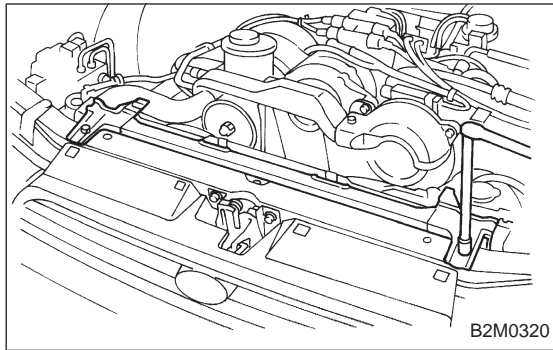

8) Remove radiator upper brackets.

NOTE:

Place left upper radiator bracket between grille and body.

9) While slightly lifting radiator, slide it to left.

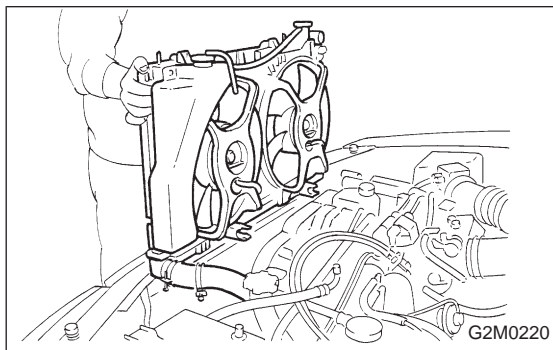

10) Lift radiator up and away from vehicle.

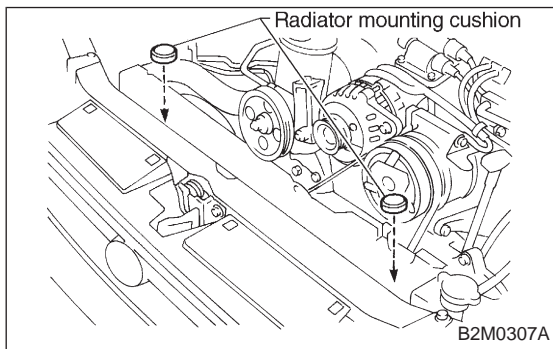

B: INSTALLATION

1) Attach radiator mounting cushions to body.

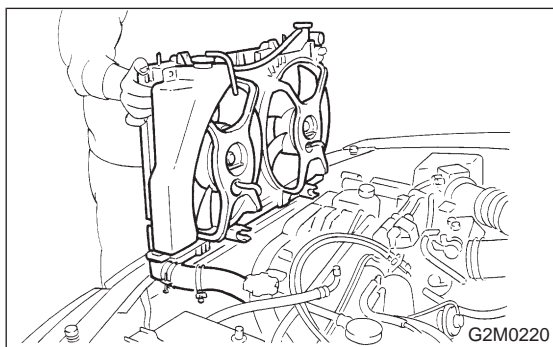

2) Install radiator while fitting radiator pins to cushions.

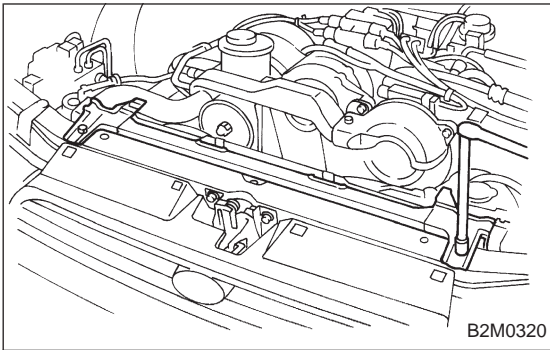

- 3) Install radiator brackets and tighten bolts.
- 4) Connect radiator main fan motor and sub fan motor connectors.

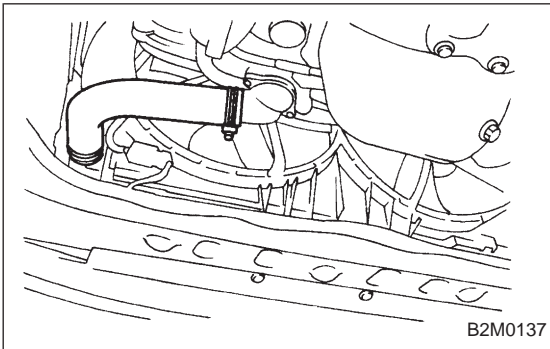

- 5) Connect radiator inlet and outlet hoses.
- 6) Connect ATF cooler hoses. (AT model)

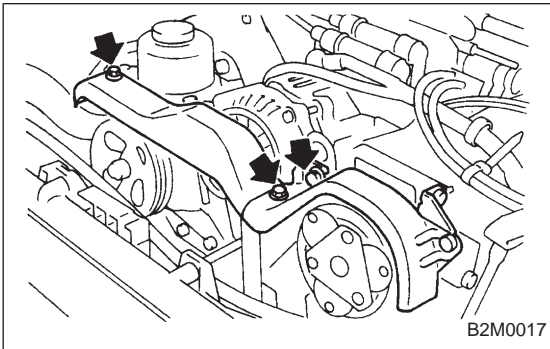

- 7) Install V-belt cover.

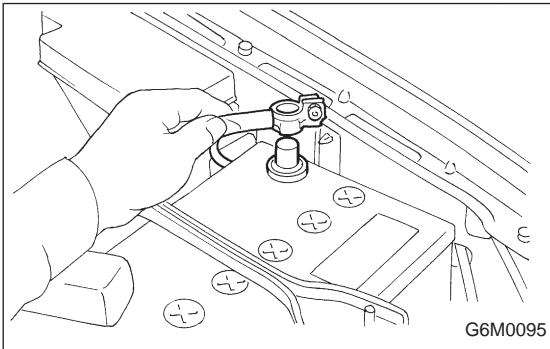

- 8) Connect ground cable to battery terminal.