

8. Fuel Delivery, Return and Evaporation Lines

A: REMOVAL

- 1) Release fuel pressure. <Ref. to 2-8 [W1A0].>
- 2) Remove inner trim, insulator and rear seat.
- 3) Remove fuel delivery pipes and hoses, fuel return pipes and hoses, and evaporation pipes and hoses.

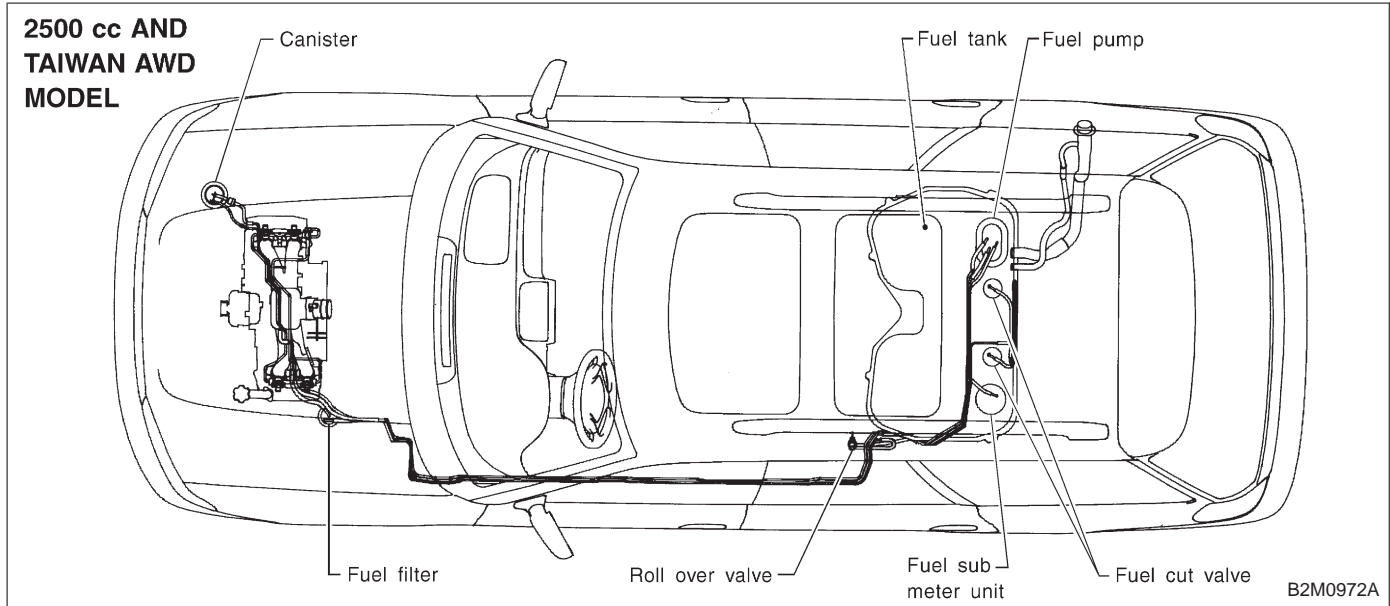

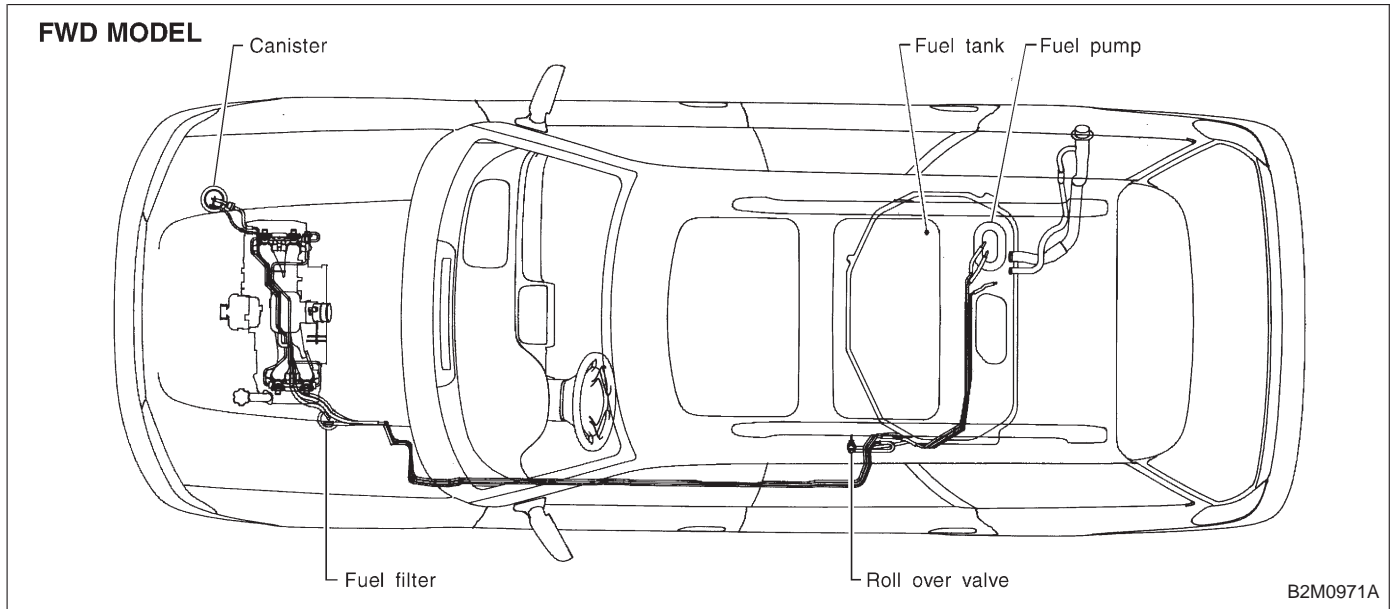
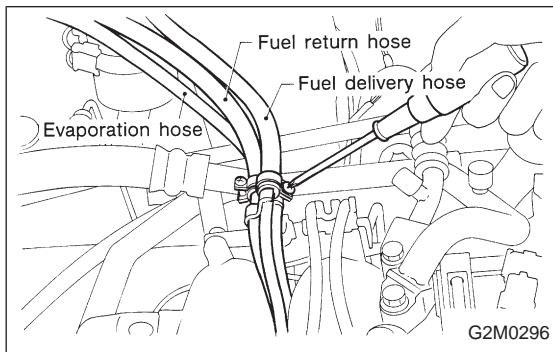
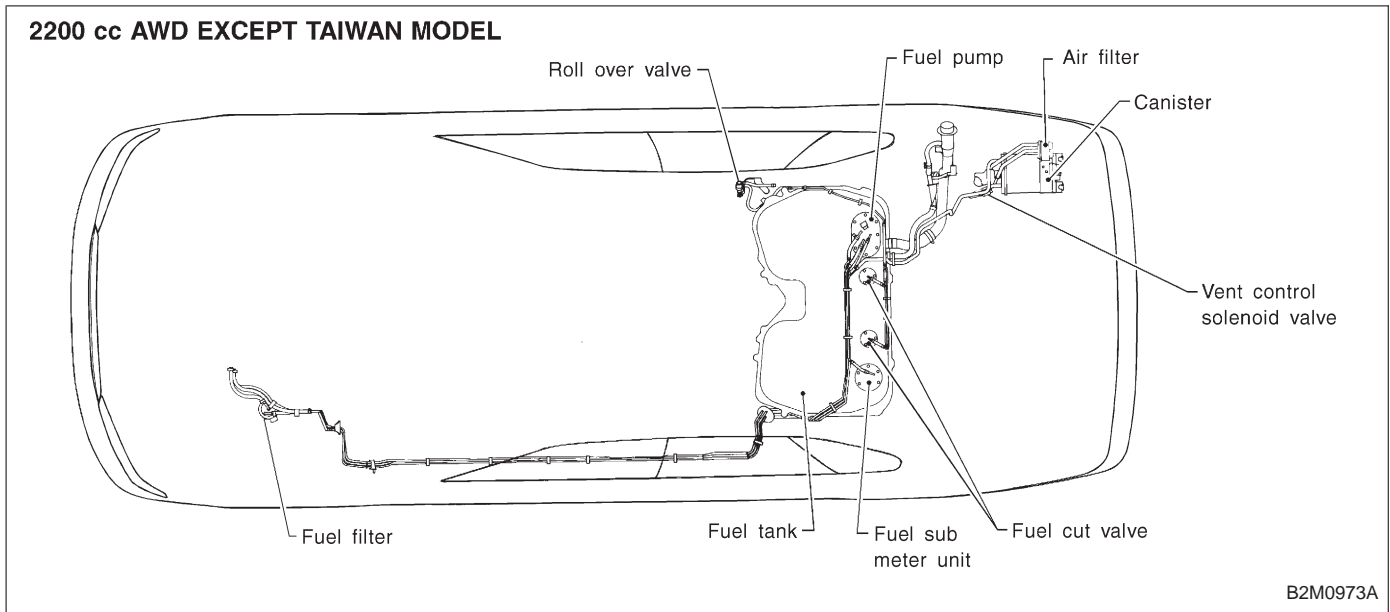

4) In engine compartment, detach fuel delivery hose, return hose and evaporation hose.

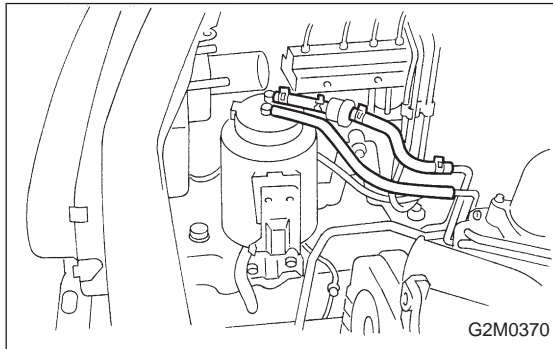

5) In engine compartment, detach canister hoses from canister. (Except 2200 cc AWD model)

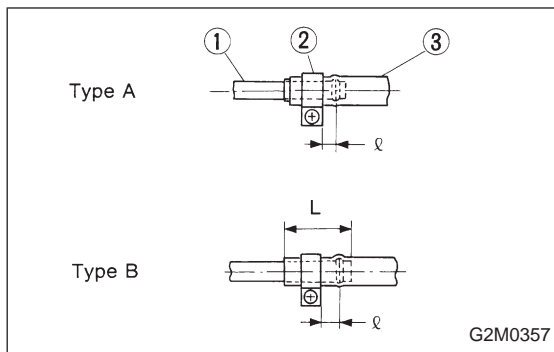
**B: INSTALLATION**

Installation is in the reverse order of removal.

1) Connect fuel delivery hose to pipe with an overlap of 20 to 25 mm (0.79 to 0.98 in).

Type A: When fitting length is specified.

Type B: When fitting length is not specified.

- ① Fitting
- ② Clamp
- ③ Hose

ℓ : 1.0 — 4.0 mm (0.039 — 0.157 in)

L : 20 — 25 mm (0.79 — 0.98 in)

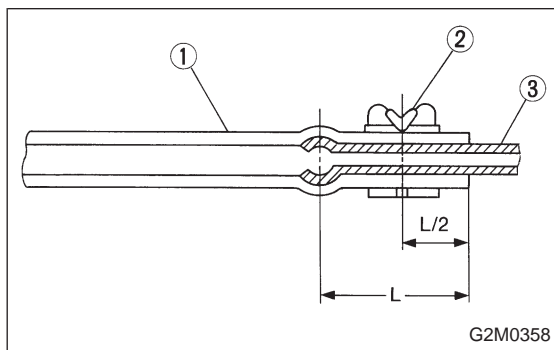

2) Connect evaporation hose to pipe by approx. 15 mm (0.59 in) from hose end.

- ① Hose
- ② Clip
- ③ Pipe

$L = 15 — 20$ mm (0.59 — 0.79 in)

CAUTION:

Be sure to inspect hoses and their connections for any leakage of fuel.