

11. Compressor

Compressor is a swash plate type. When trouble occurs, replace compressor as a single unit.

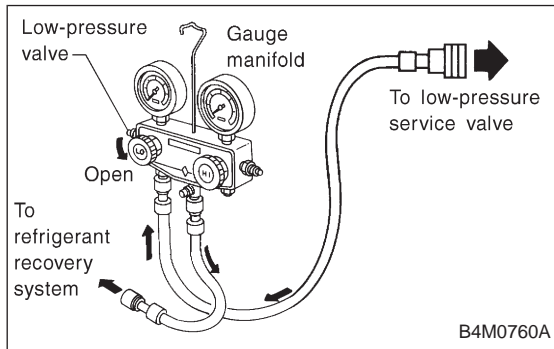
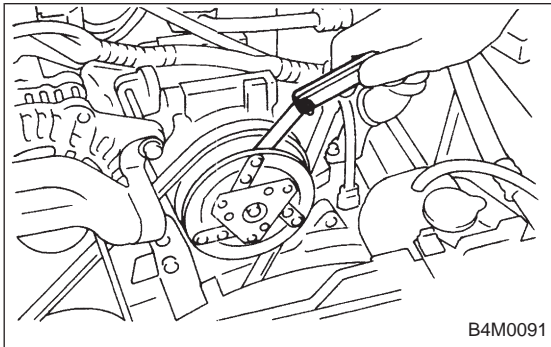
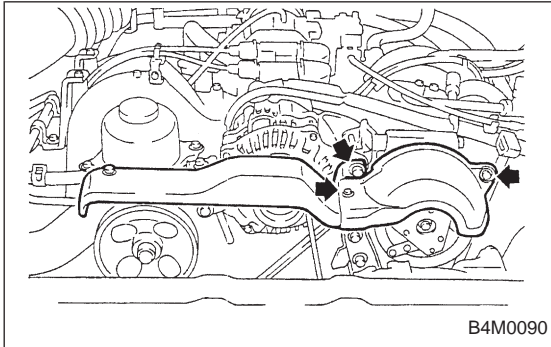

A: COMPRESSOR CLUTCH INSPECTION

Compressor clutch trouble is often caused by clutch slippage and noise. Check and take corrective measures, as required.

- 1) Remove belt cover.
- 2) Check that clearance between drive plate and pulley over the entire perimeter is within specifications.

Clearance:

0.3 — 0.6 mm (0.012 — 0.024 in)

- 3) Check that voltage applied to magnetic coil is at least 10.5 volts.
- 4) When noise is noted, check that it originates in either compressor or pulley bearing.

B: REMOVAL

- 1) Disconnect ground cable from battery.
- 2) Discharge refrigerant using refrigerant recovery system. <Ref. to 4-7 [W601].>

- (1) Fully close low-pressure valve of manifold gauge.
- (2) Connect low-pressure charging hose of manifold gauge to low-pressure service valve.
- (3) Open low-pressure manifold gauge valve slightly, and slowly discharge refrigerant from system.

CAUTION:

Do not allow refrigerant to rush out. Otherwise, compressor oil will be discharged along with refrigerant.

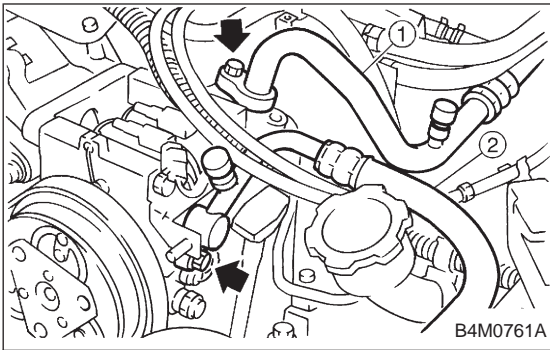

3) Remove low-pressure hose ① (Flexible hose Ps) and high-pressure hose ② (Flexible hose Pd).

CAUTION:

- Be careful not to lose O-ring of low-pressure hose.
- Plug the opening to prevent foreign matter from entering.

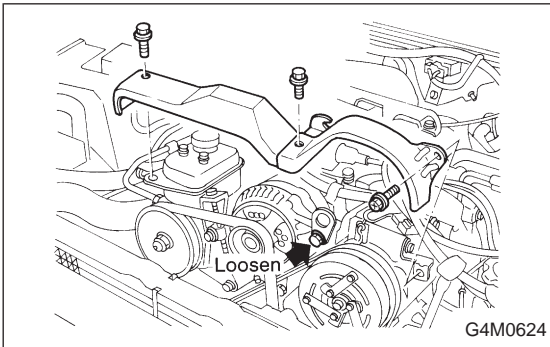

4) Remove compressor belt cover and alternator belt cover.

Remove bolts which secure belt covers.

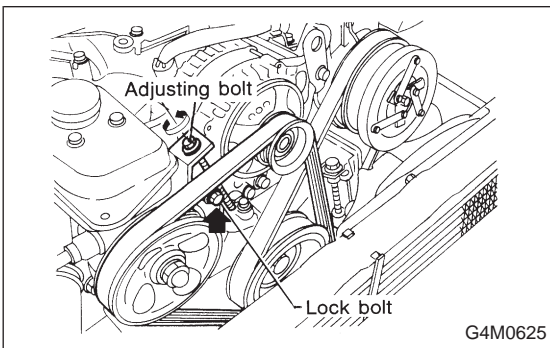

5) Remove alternator V-belt.

Loosen lock bolt on alternator bracket. Turn adjusting bolt and remove V-belt.

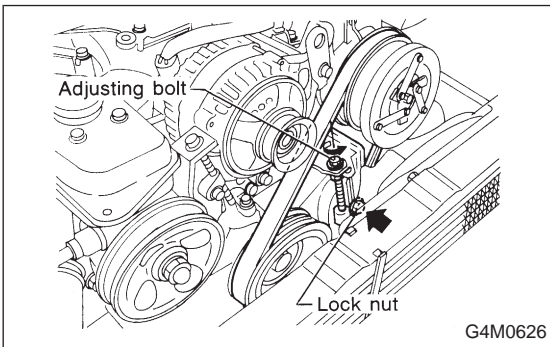

6) Remove compressor V-belt.

Loosen lock nut on idler pulley. Turn adjusting bolt and remove V-belt.

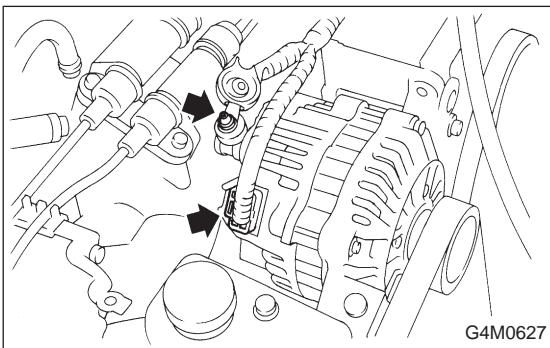

7) Disconnect alternator harness.

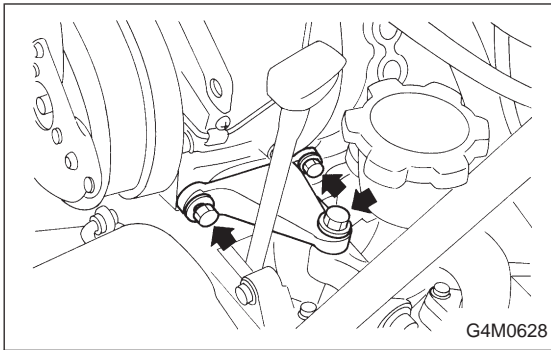

- 8) Disconnect compressor harness.
Disconnect compressor harness from body harness.
- 9) Lower bracket.
Remove bolts which secure lower compressor bracket.

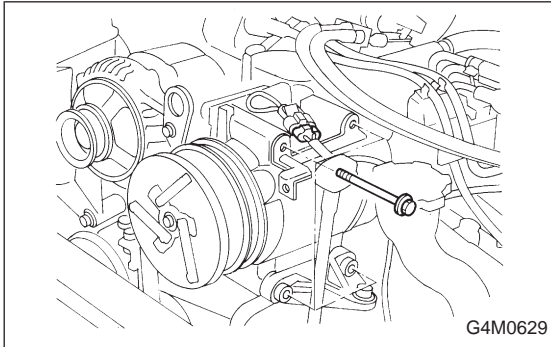

- 10) Remove compressor.
Remove bolt which secure compressor. Remove compressor from bracket.

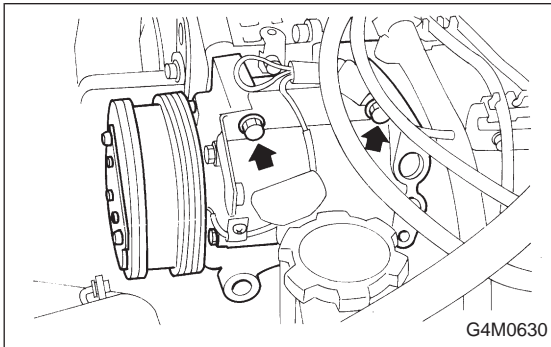

C: INSTALLATION

- 1) Install compressor.
Install compressor on bracket.

- 2) Connect compressor harness.
- 3) Connect alternator harness.
- 4) Install compressor V-belt (Rear).
After adjusting belt tension, tighten tension pulley lock nut securely.

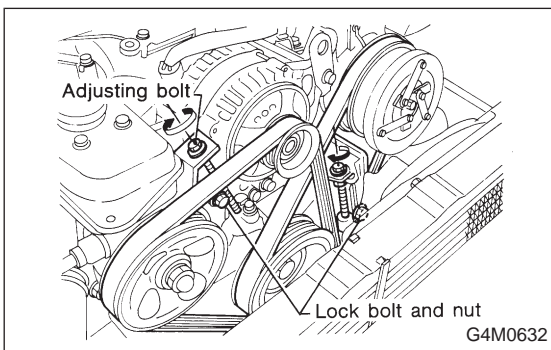

- 5) Install alternator V-belt.
After adjusting V-belt tension, tighten alternator bracket lock bolt securely.
- 6) Check drive belt tension and adjust it if necessary by changing alternator position and/or idler pulley position.

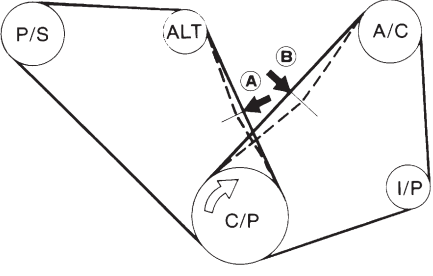
Pulley arrangement	Tension mm (in)/98N (10 kg, 22 lb)	
	A	B
 <p>G4M0939</p>	<p>*New belt: 7.0 — 9.0 (0.276 — 0.354) Existing belt: 9.0 — 11.0 (0.354 — 0.433)</p>	<p>*New belt: 7.5 — 8.5 (0.295 — 0.335) Existing belt: 9.0 — 10.0 (0.354 — 0.394)</p>

* When replacing belts with new ones, adjust tensions to specification and then readjust to the same specification after running engine for 5 minutes.

Figures in table refer to the number of grooves in pulleys.

C/P : Crankshaft pulley

ALT : Alternator pulley

P/S : Power steering oil pump pulley

A/C : Air conditioner compressor pulley

I/P : Idler pulley

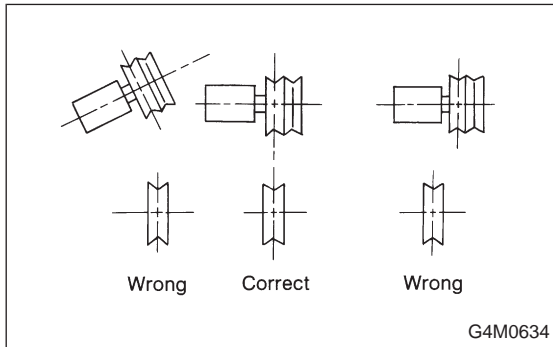

CAUTION:

● Ensure that the V-belt is aligned correctly. If it is not, check for loose bolts.

● The V-belt should not be too tight or too loose. A belt which is too tight may break bearing or cause gas to leak from the shaft seal. A belt which is too loose slips, thereby causing the belt cut.

● After completing the compressor installation and testing the system operation, check and adjust the tension of both V-belts again.

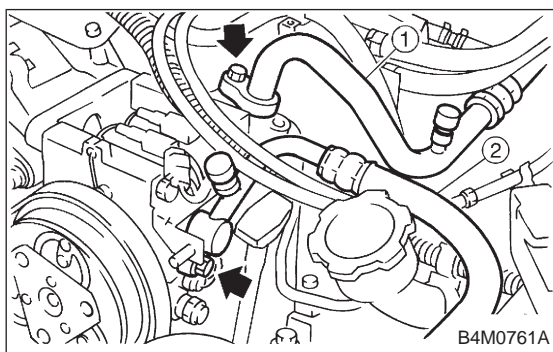

7) Install high-pressure hose ② (Flexible hose Pd). Connect high-pressure hose with compressor.

CAUTION:

Be sure to apply compressor oil to the periphery of O-ring.

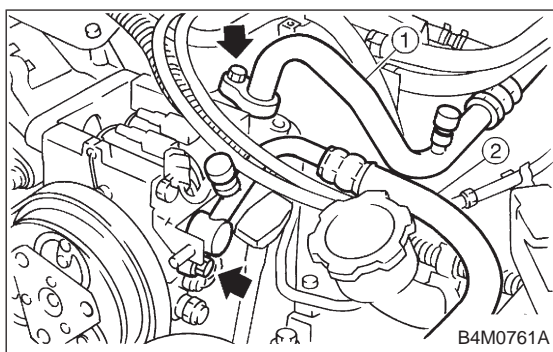

8) Install low-pressure hose ① (Flexible hose Ps). Connect low-pressure hose with compressor.

CAUTION:

Be sure to apply compressor oil to the periphery of O-ring.

- 9) Install belt cover.
- 10) Connect ground cable to negative terminal of battery.
- 11) Charge refrigerant. <Ref. to 4-7 [W708].>

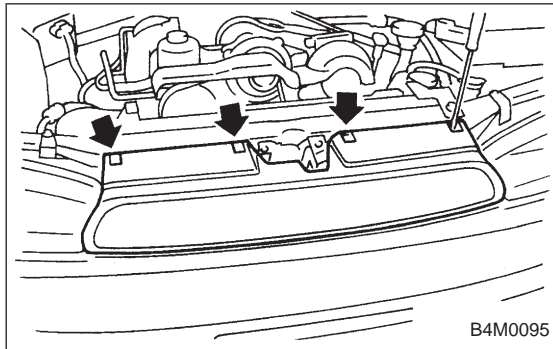

12. Condenser

A: REMOVAL AND INSTALLATION

- 1) Disconnect battery negative terminal.
- 2) Discharge refrigerant using refrigerant recovery system. <Ref. to 4-7 [W601].>
- 3) Remove front grille.

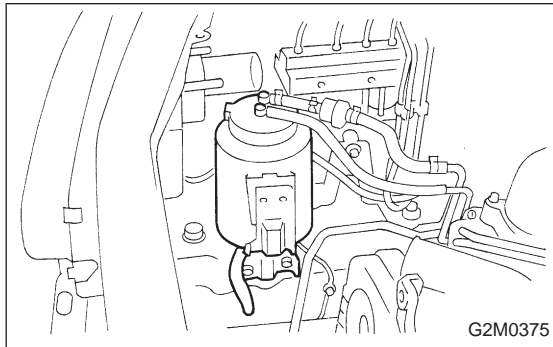

- 4) Remove canister from bracket.

CAUTION:

- Do not disconnect hose from canister.
- Insert air vent hose of canister into the hole on body.

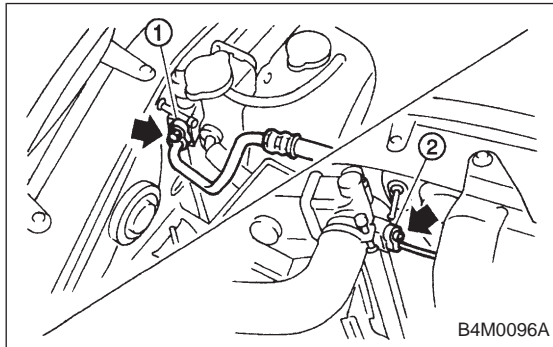

- 5) Remove the radiator upper bracket of both side.
- 6) Disconnect high-pressure hose ① and high-pressure pipe ② from condenser.

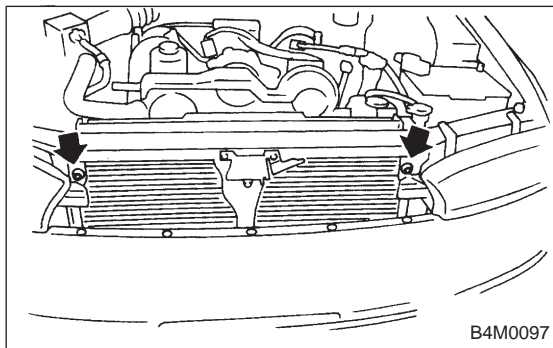

- 7) Remove the two bolts which secure condenser. While lifting condenser, remove it through space between radiator and radiator panel.