

5. Intake Door Motor

A: REMOVAL

- 1) Disconnect GND cable from battery.
- 2) Remove glove box and pocket back panel. <Ref. to 5-4 [W1A0].>
- 3) Remove heater duct or evaporator. (With A/C model). <Ref. to 4-7 [W14A0].>

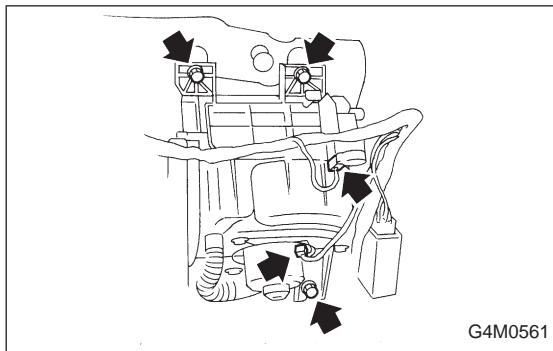

- 4) Remove intake unit from the vehicle.

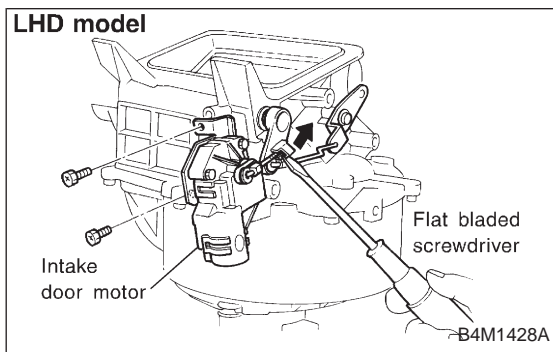

- 5) Remove screws which secure intake door motor to intake unit.

NOTE:

Ensure that RECIRC switch is set to "ON".

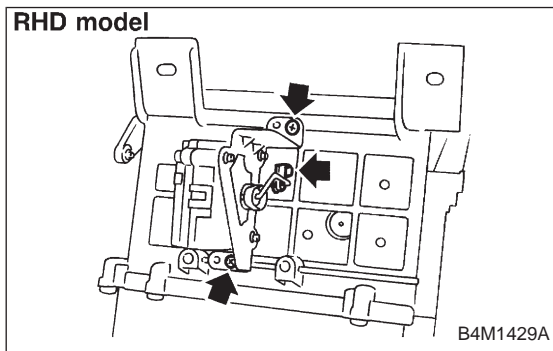

5. Intake Door Motor

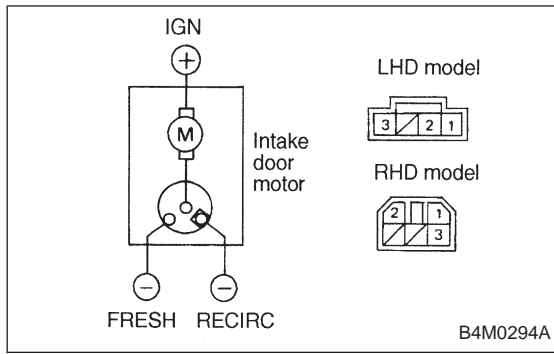

B: INSPECTION

1) When approx. 12 V is applied to the intake door motor terminals, intake door motor operates as follows:

Intake door motor position	Terminal		Intake door motor operation
	⊕	⊖	
FRESH	3*	2* 1**	Door motor moved to FRESH position.
RECIRC	2**	1* 3**	Door motor moved to RECIRC position.

*: LHD model
 **: RHD model

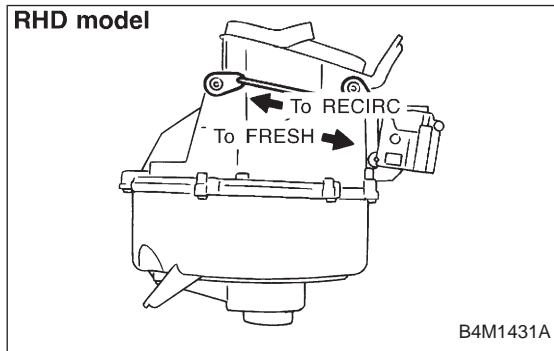
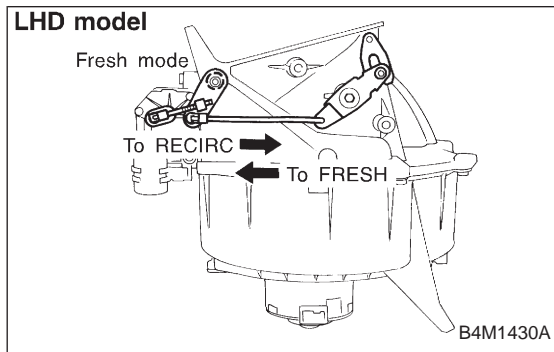

- 2) Connect harness to intake door motor.
- 3) Turn ignition switch to "ACC" and RECIRC switch to "ON" then, set to "RECIRC".

NOTE:

Ensure that intake door motor is set in the "RECIRC" mode.

- 4) Install intake door motor on intake unit.
- 5) Secure rod holder to link, and install link to intake unit.
- 6) Manually set rod in the "RECIRC" mode, and secure to rod holder.
- 7) Operate mode selector switch to ensure that system changes from intake air to "RECIRC" and from "RECIRC" to intake air in full-stroke range.

C: INSTALLATION

Installation is in the reverse order of removal.