

3. Front Ball Joint

A: REMOVAL

- 1) Remove the wheel.
- 2) Pull out the cotter pin from the ball stud, remove the castle nut, and extract the ball stud from the transverse link.
- 3) Remove the bolt securing the ball joint to the housing.
- 4) Extract the ball joint from the housing.

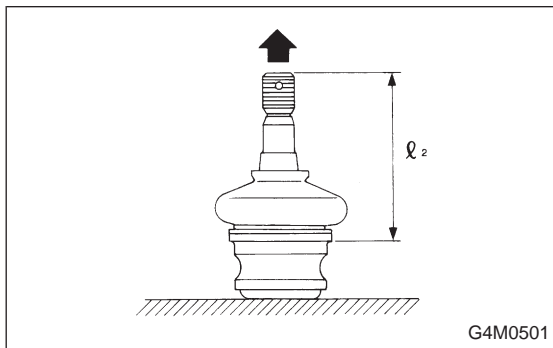
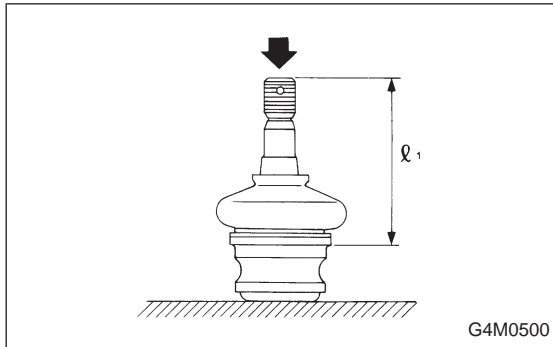

B: INSPECTION

- 1) Measure play of ball joint by the following procedures. Replace with a new one when the play exceeds the specified value.

(1) With 686 N (70 kg, 154 lb) loaded in the direction shown in the figure, measure dimension l_1 .

(2) With 686 N (70 kg, 154 lb) loaded in the opposite direction shown in the figure, measure dimension l_2 .

(3) Calculate plays from the following formula.

$$S = l_2 - l_1$$

(4) When plays are larger than the following value, replace with a new one.

FRONT BALL JOINT

Specified play for replacement: S
Less than 0.3 mm (0.012 in)

- 2) When play is smaller than the specified value, visually inspect the dust cover.
- 3) If the dust cover is damaged, replace with the new ball joint.
- 4) Check ball joint for damage and cracks. If defective, replace with new one.

C: INSTALLATION

- 1) Install ball joint onto housing.

Torque (Bolt):

$49 \pm 10 \text{ N}\cdot\text{m}$ ($5.0 \pm 1.0 \text{ kg}\cdot\text{m}$, $36 \pm 7 \text{ ft}\cdot\text{lb}$)

CAUTION:

Do not apply grease to tapered portion of ball stud.

- 2) Connect ball joint to transverse link.

Torque (Castle nut):

$39 \text{ N}\cdot\text{m}$ ($4.0 \text{ kg}\cdot\text{m}$, $29 \text{ ft}\cdot\text{lb}$)

- 3) Retighten castle nut further within 60° until a slot in castle nut is aligned with the hole of ball stud end, then insert new cotter pin and bend it around castle nut.

- 4) Install front wheel.