

6) Recheck that starting torque is within specified range, then clinch lock nut at four positions.

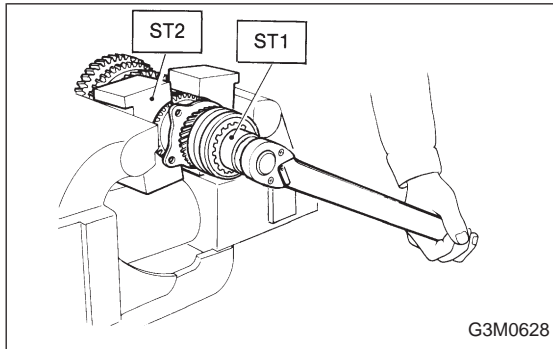

6. Drive Pinion Assembly (FWD Model)

A: DISASSEMBLY

1) Loosen lock nut using ST1 and ST2.

ST1 499987100 or 499987003 or 899984103 SOCKET WRENCH (35)

ST2 899884100 HOLDER

NOTE:

Remove caulking before taking off lock nut.

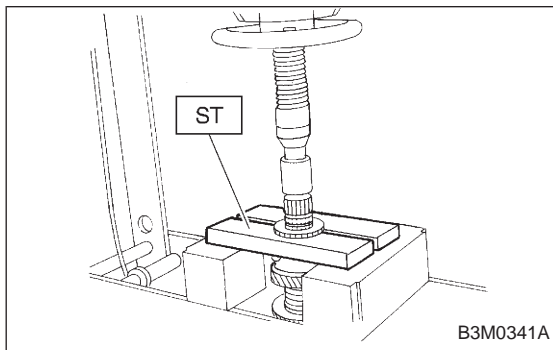

2) Remove 5th driven gear using a press.

ST 498077000 5TH DRIVEN GEAR REMOVER

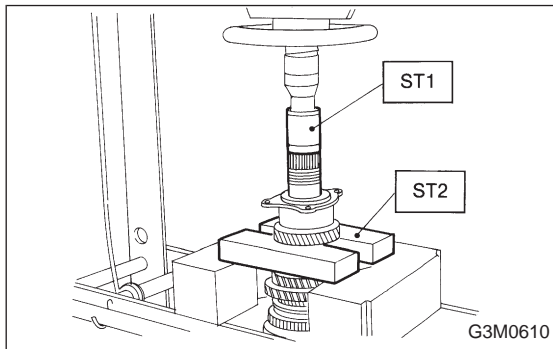

3) Remove woodruff key.

4) Remove roller bearing (29 x 74 x 38) and 3rd-4th driven gear using ST1 and ST2.

ST1 899714110 REMOVER

ST2 499757002 SNAP RING PRESS

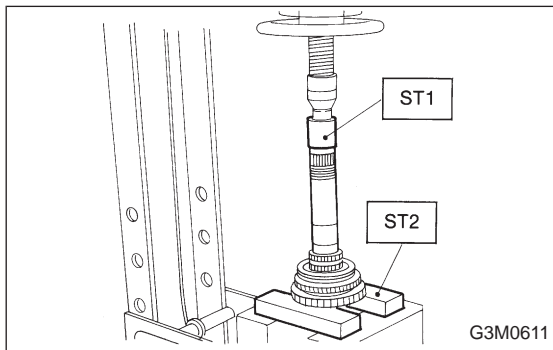

5) Remove 2nd driven gear assembly.

6) Remove 3rd-4th driven gear key.

7) Remove 1st driven gear, 2nd gear bushing, and gear & hub assembly using ST1 and ST2.

Replace gear and hub if necessary. Do not attempt to disassemble if at all possible because they must engage at a specified point. If they have to be disassembled, mark the engaging point beforehand.

ST1 499757002 SNAP RING PRESS

ST2 899714110 REMOVER

6. Drive Pinion Assembly (FWD Model)

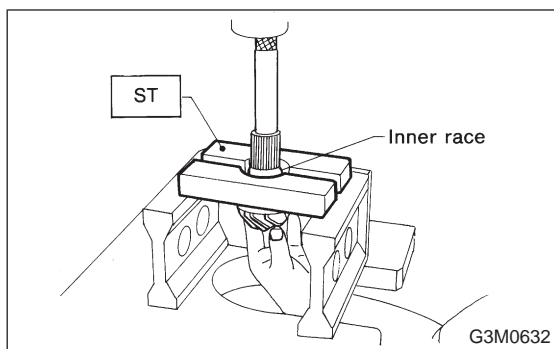

8) Remove 1st gear bushing, 1st driven gear thrust plate, and roller bearing (41 x 71 x 23) using ST and press.

ST 498517000 REPLACER

CAUTION:

Replace roller bearing (41 x 71 x 23) with a new one if this disassembly is performed.

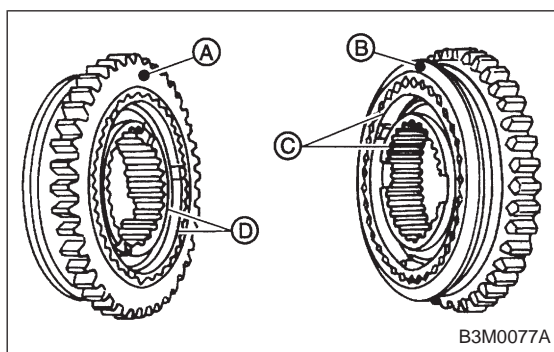
**B: ASSEMBLY**

1) Assemble gear and hub assembly.

- Ⓐ: 1st gear side
- Ⓑ: 2nd gear side
- Ⓒ: Flush surface
- Ⓓ: Stepped surface

NOTE:

- Use new gear and hub assembly, if gear or hub have been replaced.
- Position open ends of springs 120° apart.

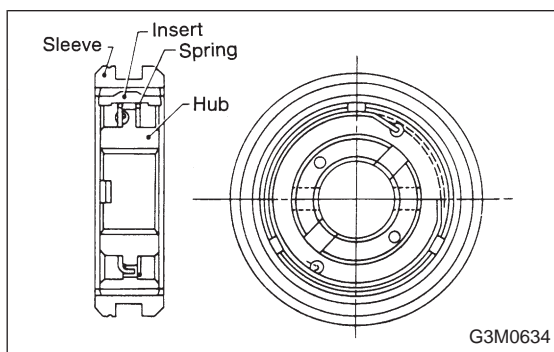

2) Assemble sleeve and hub assembly.

NOTE:

Make sure bent sections of springs on both sides are kept 180° apart and hooked at hub's holes.

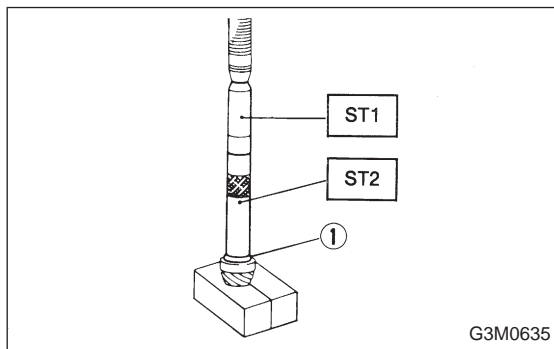

3) Drive roller bearing onto drive pinion shaft and 1st driven gear thrust washer ① using ST1 and ST2.

ST1 499877000 INSTALLER

ST2 499277100 INSTALLER

CAUTION:

Use new roller bearing, 1st gear thrust washer.

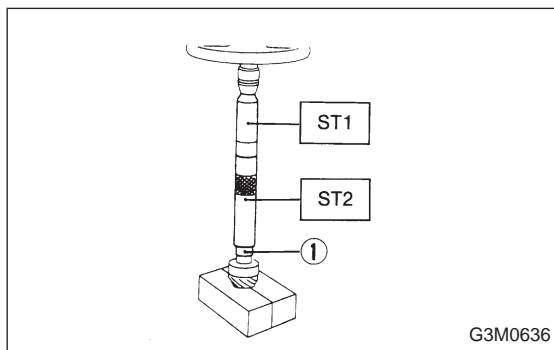

4) Install 1st-2nd driven gear bushing ① onto drive pinion shaft.

NOTE:

Bushing may be installed with either side up.

ST1 499877000 INSTALLER

ST2 499277100 INSTALLER

5) Measure outside diameter of 1st driven gear bushing to determine suitable 1st driven gear.

Bushing outside diameter mm (in)	1st driven gear
41.983 — 41.996 (1.6529 — 1.6534)	32231AA320
41.968 — 41.982 (1.6523 — 1.6528)	32231AA330
41.954 — 41.967 (1.6517 — 1.6522)	32231AA340

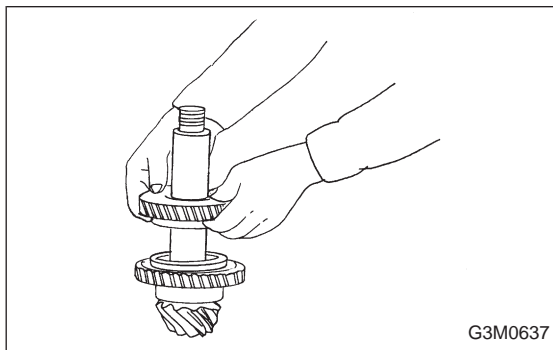

6) Install 1st driven gear, 1st-2nd bask ring and gear and hub assembly (already assembled in previous step) to drive pinion shaft by hand.

NOTE:
Align ring groove with insert.

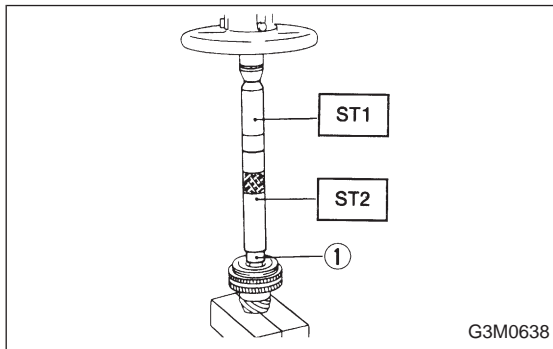

7) Install 1st-2nd driven gear bushing ① to drive pinion shaft using ST1 and ST2.

ST1 499877000 INSTALLER
ST2 499277100 INSTALLER

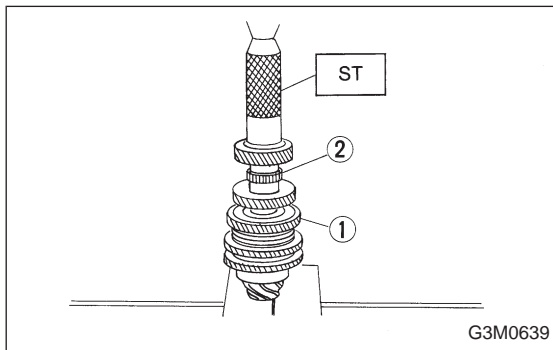

8) Install 2nd driven gear ① and 1st-2nd bask ring to drive pinion shaft by hand.

9) Install key into the groove on drive pinion shaft and install 3rd-4th driven gear.

NOTE:
Ball bearing may be installed without using the tool. There should be no problem.

ST 499877000 INSTALLER

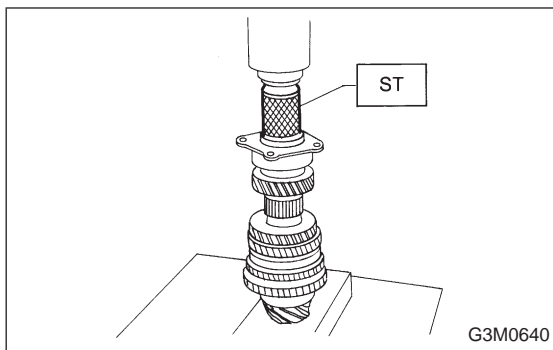

10) Install ball bearing (29 x 74 x 38) on drive pinion shaft with ST.

ST 499277100 INSTALLER

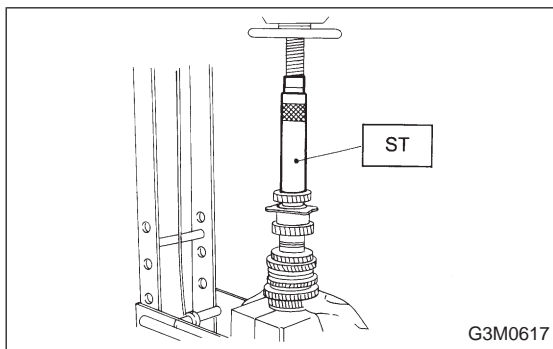

11) Position woodruff key in groove on the rear of drive pinion shaft. Install 5th driven gear onto drive shaft using ST and press.

ST 499277100 INSTALLER

CAUTION:

- Face 5th driven gear in the correct direction.
- Be careful not to dislocate woodruff key while installing 5th gear.

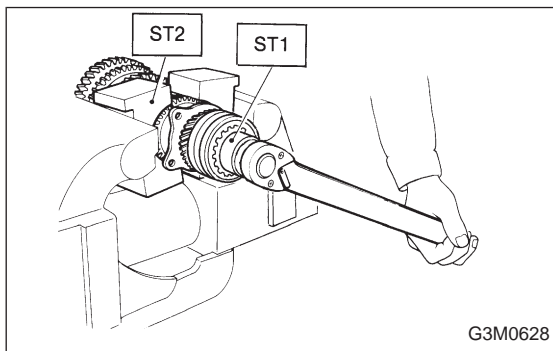
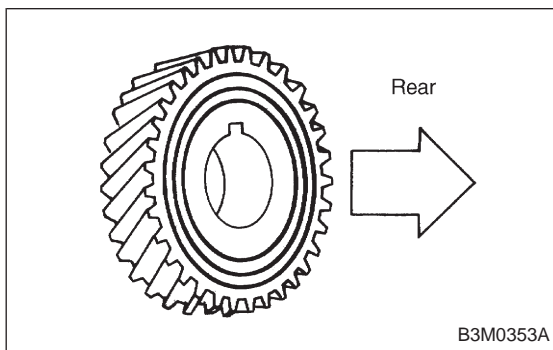

12) Install lock washer and tighten lock nut to the specified torque using ST1 and ST2.

ST1 499987100 or 499987003 or 899984103 SOCKET WRENCH (35)

ST2 899884100 HOLDER

CAUTION:

- Discard old lock nuts, replace with new ones.
- Secure lock nut in four places.

Tightening torque:

112 — 124 N·m (11.4 — 12.6 kg·m, 82 — 91 ft·lb)