

7. Repair Instructions for Colored PP Bumper

All PP bumpers are provided with a grained surface, and if the surface is damaged, it cannot normally be restored to its former condition. Damage limited to shallow scratches that cause only a

change in the lustre of the base material or coating, can be almost fully restored. Before repairing a damaged area, explain this point to the customer and get an understanding about the matter.

Repair methods are outlined below, based on a classification of the extent of damage.

A: MINOR DAMAGE CAUSING ONLY A CHANGE IN THE LUSTRE OF THE BUMPER DUE TO A LIGHT TOUCH

It is almost restorable as follows:

Process No.	Process name	Job contents	
1	Cleaning	Clean the area to be repaired using water.	
2	Sanding	Grind the repairing area with #500 sand paper in a "feathering" motion.	
3	Finish	Resin section	Coated section
		Repeatedly apply wax to the affected area using a soft cloth (such as flannel). Recommended wax: NITTO KASEI Soft 99 TIRE WAX BLACK, or equivalent.	Perform either the same operation as for the resin section or process No. 18 and subsequent operations in the "3." section, depending on the degree and nature of damage. Polish the waxed area with a clean cloth after 5 to 10 minutes.
		Polish the waxed area with a clean cloth after 5 to 10 minutes.	

B: DEEP DAMAGE CAUSED BY SCRATCHING FENCES, ETC.

A dent cannot be repaired but a whitened or swelled part can be removed.

Process No.	Process name	Job contents	
1	Cleaning	Clean damaged area with water.	
2	Removal of damaged area	Cut off protruding area, if any, due to collision, using a putty knife.	
3	Sanding	Grind the affected area with #100 to #500 sand paper.	
4	Finish	Resin section	Coated section
		Same as process No. 3 in the "1." section.	Perform process No. 12 and subsequent operations in the "3." section.

C: DEEP DAMAGE SUCH AS A BREAK OR HOLE THAT REQUIRES FILLING

Much of the peripheral grained surface must be sacrificed for repair, and the degree of restoration is not really worth the expense. (The surface, however, will become almost flush with adjacent areas.)

Recommended repair kit: PP Part Repair Kit (NRM)

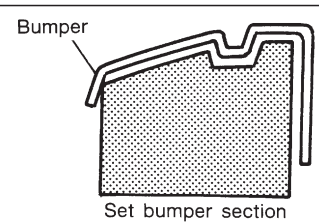
Process No.	Process name	Job contents	
1	Bumper removal	Remove bumper as required.	
2	Parts removal	Place bumper on a paint work table as required.	
3	Bumper placement	Place bumper on a paint work table as required. It is recommended that contour of work table accommodates internal shape of bumper.	
4	Surface preparation	Remove dust, oil, etc. from areas to be repaired and surrounding areas, using a suitable solvent (NRM No. 900 precleno, white gasoline, or alcohol).	

G5M0164

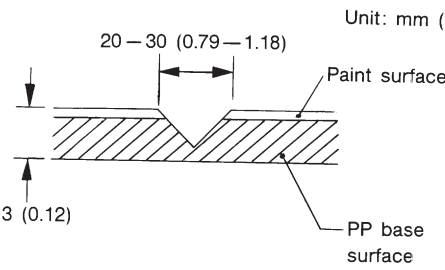
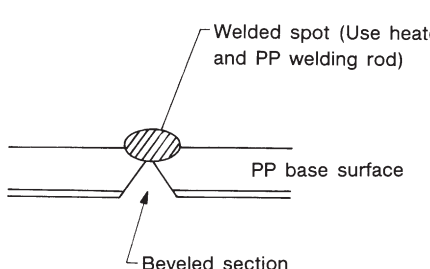
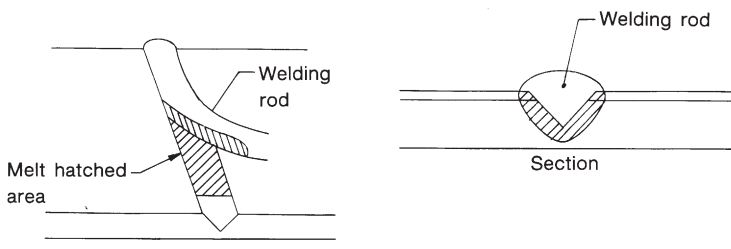
Process No.	Process name	Job contents	
5	Cutting	<p>If nature of damage are cracks or holes, cut a guide slit of 20 to 30 mm (0.79 to 1.18 in) in length along the crack or hole up to the bumper's base surface. Then, bevel or "vee- out" the affected area using a knife or grinder.</p>	<p style="text-align: right;">Unit: mm (in)</p>  <p style="text-align: right;">G5M0165</p>
6	Sanding (I)	Grind beveled surface with sand paper (#40 to #60) to smooth finish.	
7	Cleaning	Clean the sanded surface with the same solvent as used in process No. 4.	
8	Temporary welding	<p>Grind the side just opposite the beveled area with sand paper (#40 to #60) and clean using a solvent. Temporarily spot-weld the side, using a PP welding rod and heater gun.</p>	 <p style="text-align: right;">G5M0166</p> <p>NOTE:</p> <ul style="list-style-type: none"> ● Do not melt welding rod until it flows out. This results in reduced strength. ● Leave the welded spot unattended until it cools completely.
9	Welding	<p>Using a heater gun and PP welding rod, weld the beveled spot while melting the rod and damaged area.</p>	 <p style="text-align: right;">G5M0167</p> <p>NOTE:</p> <ul style="list-style-type: none"> ● Melt the sections indicated by hatched area. ● Do not melt welding rod until it flows out, in order to provide strength. ● Always keep the heater gun 1 to 2 cm (0.4 to 0.8 in) away from the welding spot. ● Leave the welded spot unattended until it cools completely.

SERVICE PROCEDURE

[W7C0] 5-1

7. Repair Instructions for Colored PP Bumper

Process No.	Process name	Job contents
10	Sanding (II)	Remove excess part of weld with a putty knife. If a drill or disc wheel is used instead of the knife, operate it at a rate lower than 1,500 rpm and grind the excess part little by little. A higher rpm will cause the PP substrate to melt from the heat.
		 <p style="text-align: right;">G5M0168</p>
		Sand the welded spot smooth with #240 sand paper.
11	Masking	Mask the black substrate section using masking tape. Recommended masking tape: Nichiban No. 533 or equivalent
12	Cleaning/ degreasing	Completely clean the entire coated area, using solvent similar to that used in process No. 4.
13	Primer coating	Apply a coat of primer to the repaired surface and its surrounding areas. Mask these areas, if necessary. Recommended primer: Mp/ 364 PP primer NOTE: Be sure to apply one coat of primer at a spraying pressure of 245 to 343 kPa (2.5 to 3.5 kg/cm ² , 36 to 50 psi) with a spray gun.
14	Leave unattended.	Leave the repaired area unattended at 20°C (68°F) for 10 to 15 minutes until primer is half-dry. NOTE: If dirt or dust comes in contact with the coated area, wipe it off with a cloth dampened with alcohol. (Do not use thinner since the coated area tends to melt.)
15	Primer surfacer coating	Apply a coat of primer surfacer to the repaired area two or three times at an interval of 3 to 5 minutes. Recommended surfacer: <ul style="list-style-type: none"> ● UPS 300 Flex primer ● No. 303 UPS 300 Exclusive hardener ● NPS 725 Exclusive reducer (thinner) ● Mixing ratio: 2 : 1 (UPS 300: No. 303) ● Viscosity: 12 — 14 sec/20°C (68°F) ● Coated film thickness: 40 — 50μ
16	Drying	Allow the coated surface to dry for 60 minutes at 20°C (68°F) [or 30 minutes at 60°C (140°F)].
17	Sanding (III)	Sand the coated surface and its surrounding areas using #400 sand paper and water.
18	Cleaning/ degreasing	Same as process No. 12.
19	Top coat	Solid color
		Use a “block” coating method. ● Recommended paint: Suncryl (SC) No. 307 Flex hardener SC reducer (thinner) ● Mixing ratio: 3 : 1 Suncryl (SC) vs. No. 307 Flex hardener ● Viscosity: 11 — 13 sec/20°C (68°F) ● Coated film thickness: 40 — 50μ ● Spraying thickness: 245 — 343 kPa (2.5 — 3.5 kg/cm ² , 36 — 50 psi)
		Metallic color
		Use a “block” coating method. ● Recommended paint: Suncryl (SC) No. 307 Flex hardener SC Reducer (thinner) ● Mixing ratio: 3 : 1 Suncryl (SC) vs. No. 307 Flex Hardener ● Viscosity: 11 — 13 sec/20°C (68°F) ● Coated film thickness: 20 — 30μ ● Spraying thickness: 245 — 343 kPa (2.5 — 3.5 kg/cm ² , 36 — 50 psi)
20	Leave unattended.	Not required. Leave unattended at 20°C (68°F) for at least 10 minutes until the top coated area is half-dry. NOTE: Be careful to keep dust or dirt from coming in contact with the affected area.

Process No.	Process name	Job contents
21	Top coat (II)	Not required. Apply a clear coat three times at an interval of 3 to 5 minutes. ● Recommended paint: Suncryl (SC) No. 307 Flex hardener SC Reducer (thinner) ● Mixing ratio: 3 : 1 Suncryl (SC) vs. No. 307 Flex Hardener ● Viscosity: 11 — 13 sec/20°C (68°F) ● Coated film thickness: 20 — 30μ ● Spraying thickness: 245 — 343 kPa (2.5 — 3.5 kg/cm ² , 36 — 50 psi)
22	Drying	Allow the coated surface to dry at 20°C (68°F) for two hours or 60°C (140°F) for 30 minutes. NOTE: Do not allow the temperature to exceed 80°C (176°F) since this will deform the PP substrate.
23	Inspection	Carefully check the condition of the repaired area.
24	Masking removal	Remove masking tape applied in process No. 11 and 13.
25	Parts installation	Install parts on bumper in reverse order of removal.
26	Bumper installation	Install bumper.

8. Front Fender

A: REMOVAL AND INSTALLATION

- 1) Disconnect ground cable from battery.
- 2) Remove bracket which secures mud guard to front fender.

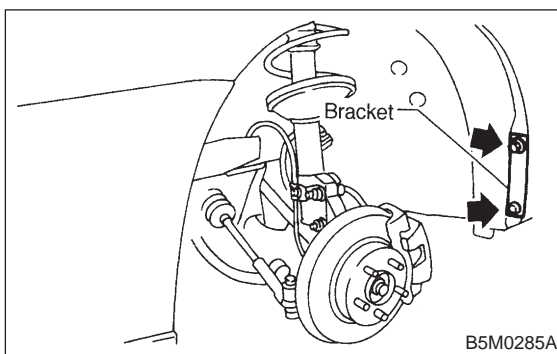

- 3) Remove mud guard. <Ref. to 5-1 [W9A1].> and <Ref. to 5-1 [W9A2].>

NOTE:

Do not remove the entire mud guard, only the front section of it.

- 4) Remove headlight. <Ref. to 6-2 [W4B2].>

- 5) Remove bolts which secure front fender. Remove front fender.

