

Process No.	Process name	Job contents
21	Top coat (II)	Not required. Apply a clear coat three times at an interval of 3 to 5 minutes. ● Recommended paint: Suncryl (SC) No. 307 Flex hardener SC Reducer (thinner) ● Mixing ratio: 3 : 1 Suncryl (SC) vs. No. 307 Flex Hardener ● Viscosity: 11 — 13 sec/20°C (68°F) ● Coated film thickness: 20 — 30μ ● Spraying thickness: 245 — 343 kPa (2.5 — 3.5 kg/cm ² , 36 — 50 psi)
22	Drying	Allow the coated surface to dry at 20°C (68°F) for two hours or 60°C (140°F) for 30 minutes. NOTE: Do not allow the temperature to exceed 80°C (176°F) since this will deform the PP substrate.
23	Inspection	Carefully check the condition of the repaired area.
24	Masking removal	Remove masking tape applied in process No. 11 and 13.
25	Parts installation	Install parts on bumper in reverse order of removal.
26	Bumper installation	Install bumper.

8. Front Fender

A: REMOVAL AND INSTALLATION

- 1) Disconnect ground cable from battery.
- 2) Remove bracket which secures mud guard to front fender.

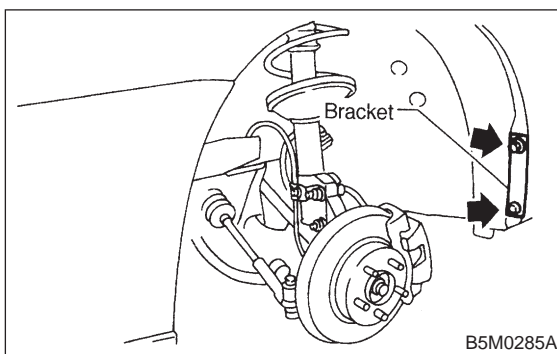

- 3) Remove mud guard. <Ref. to 5-1 [W9A1].> and <Ref. to 5-1 [W9A2].>

NOTE:

Do not remove the entire mud guard, only the front section of it.

- 4) Remove headlight. <Ref. to 6-2 [W4B2].>

- 5) Remove bolts which secure front fender. Remove front fender.

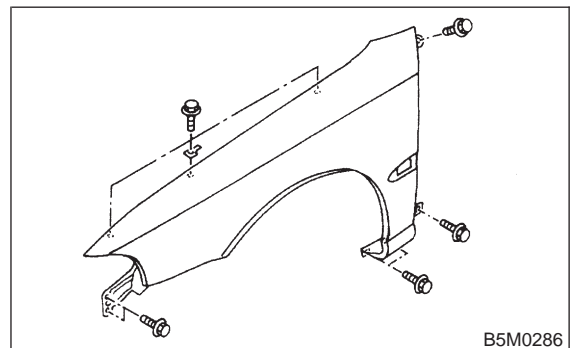

6) Installation is in the reverse order of removal.

NOTE:

Check for alignment of front fender with hood and front door with front fender at all points. Adjust, if necessary.

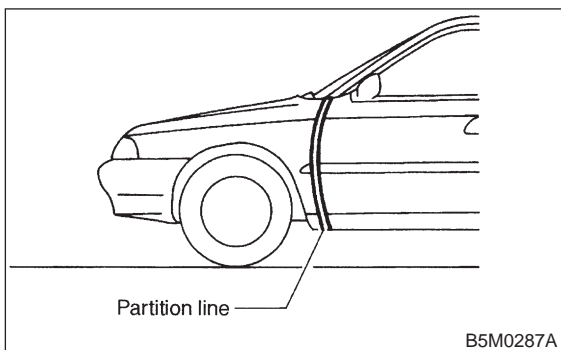
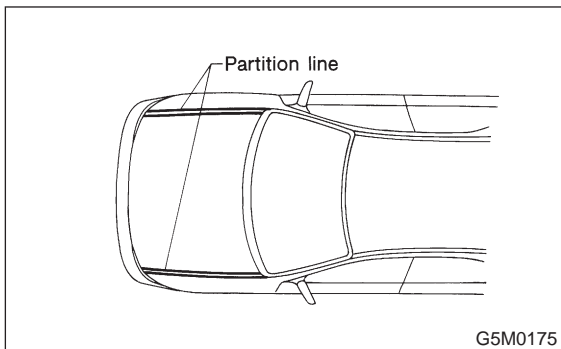

9. Mud Guard and Rear Arch Protector

A: REMOVAL AND INSTALLATION

1. MUD GUARD (EXCEPT OUTBACK MODEL)

- 1) Jack-up vehicle to remove tire.
- 2) Remove screws and clips. Move mud guard toward the center of the body and remove mud guard.

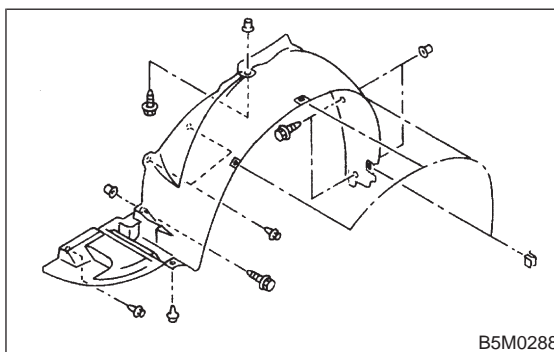

3) Installation is in the reverse order of removal.

CAUTION:

Only use new screws and clips.

2. MUD GUARD (OUTBACK MODEL)

- 1) Jack-up vehicle to remove tire.
- 2) Remove screws and clips. Move mud guard toward the center of the body and remove mud guard.

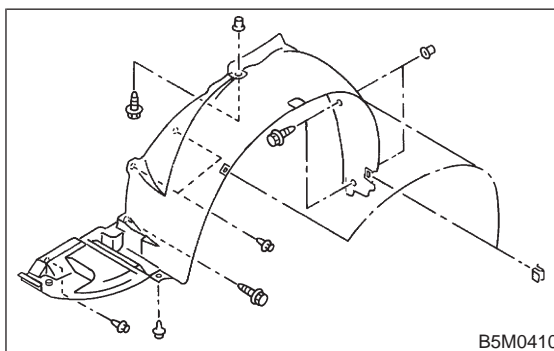

3) Installation is in the reverse order of removal.

CAUTION:

Only use new screws and clips.