

11. Molding and Retainer

A: REMOVAL AND INSTALLATION

- 1) Remove weatherstrip.
- 2) Remove tapping screws.

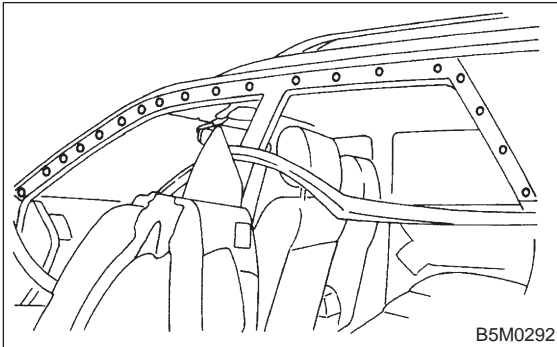

- 3) Installation is in the reverse order of removal.

NOTE:

Insert molding and retainer onto hook, then fasten with screws. Insert molding and retainer onto hook, then fasten with screws.

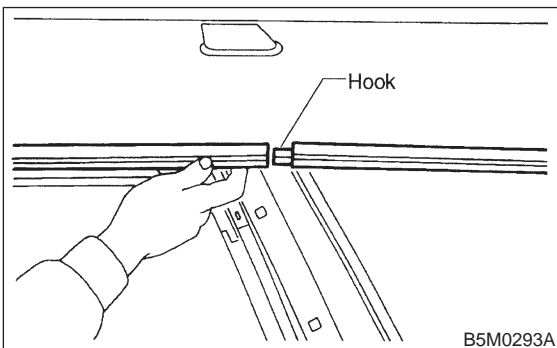

12. Front Grille

A: REMOVAL AND INSTALLATION

- 1) Remove four upper clips from body panel. To facilitate removal, press portion shown in figure using screwdriver.

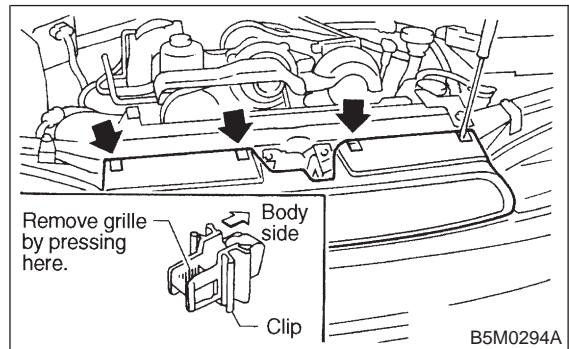

- 2) Pull front grille to detach it from two lower clips. (Two lower clips remain on headlight.)
- 3) Installation is in the reverse order of removal.

NOTE:

Attach all clips to grille. Align them with clip hole in body and push them into place.