

3-2 [T8A1] AUTOMATIC TRANSMISSION AND DIFFERENTIAL

8. Diagnostic Chart with Trouble Code

8. Diagnostic Chart with Trouble Code

A: LIST OF TROUBLE CODE

1. TROUBLE CODE

Trouble code	Item	Content of diagnosis	Title index No.
11	Duty solenoid A	Detects open or shorted drive circuit, as well as valve seizure.	<Ref. to 3-2 [T8C0].>
12	Duty solenoid B	Detects open or shorted drive circuit, as well as valve seizure.	<Ref. to 3-2 [T8D0].>
13	Shift solenoid 3	Detects open or shorted drive circuit, as well as valve seizure.	<Ref. to 3-2 [T8E0].>
14	Shift solenoid 2	Detects open or shorted drive circuit, as well as valve seizure.	<Ref. to 3-2 [T8F0].>
15	Shift solenoid 1	Detects open or shorted drive circuit, as well as valve seizure.	<Ref. to 3-2 [T8G0].>
21	ATF temperature sensor	Detects open or shorted input signal circuit.	<Ref. to 3-2 [T8H0].>
22	Mass air flow signal	Detects open or shorted input signal circuit.	<Ref. to 3-2 [T8I0].>
23	Engine speed signal	Detects open or shorted input signal circuit.	<Ref. to 3-2 [T8J0].>
24	Duty solenoid C	Detects open or shorted drive circuit, as well as valve seizure.	<Ref. to 3-2 [T8K0].>
25	Torque control signal	Detects open or shorted input signal circuit.	<Ref. to 3-2 [T8L0].>
31	Throttle position sensor	Detects open or shorted input signal circuit.	<Ref. to 3-2 [T8M0].>
32	Vehicle speed sensor 1	Detects open or shorted input signal circuit.	<Ref. to 3-2 [T8N0].>
33	Vehicle speed sensor 2	Detects open or shorted input signal circuit.	<Ref. to 3-2 [T8O0].>

2. HOW TO READ TROUBLE CODE OF INDICATOR LIGHT

The AT OIL TEMP indicator light flashes the code corresponding to the faulty part.

The long segment (1.2 sec on) indicates a "ten", and the short segment (0.2 sec on) signifies a "one".

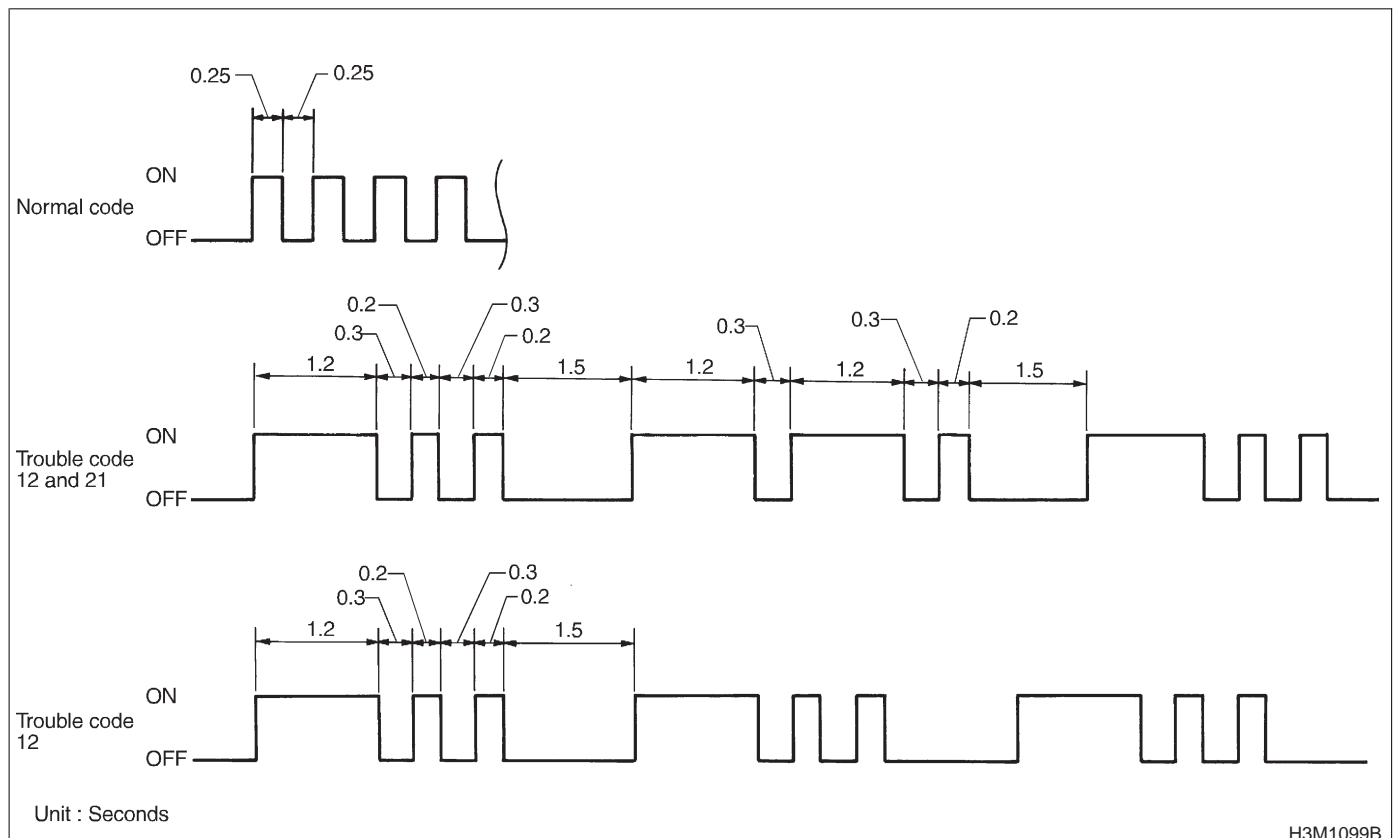

H3M1099B

B: CLEAR MEMORY

Current trouble codes shown on the display are cleared by turning the ignition switch OFF after conducting on-board diagnostics operation. Previous trouble codes, however, cannot be cleared since they are stored in the TCM memory which is operating on the back-up power supply. These trouble codes can be cleared by removing the specified fuse (located under the light or left lower position of the instrument panel).

CLEAR MEMORY:

Removal of No. 14 fuse (for at least one minute)

- The No. 14 fuse is located in the line to the memory back-up power supply of the TCM. Removal of this fuse clears the previous trouble codes stored in the TCM memory.
- Be sure to remove the No. 14 fuse for at least the specified length of time. Otherwise, trouble codes may not be cleared.

C: TROUBLE CODE 11 — DUTY SOLENOID A —

DIAGNOSIS:

Output signal circuit of duty solenoid A or resistor is open or shorted.

TROUBLE SYMPTOM:

Excessive shift shock.

WIRING DIAGRAM:

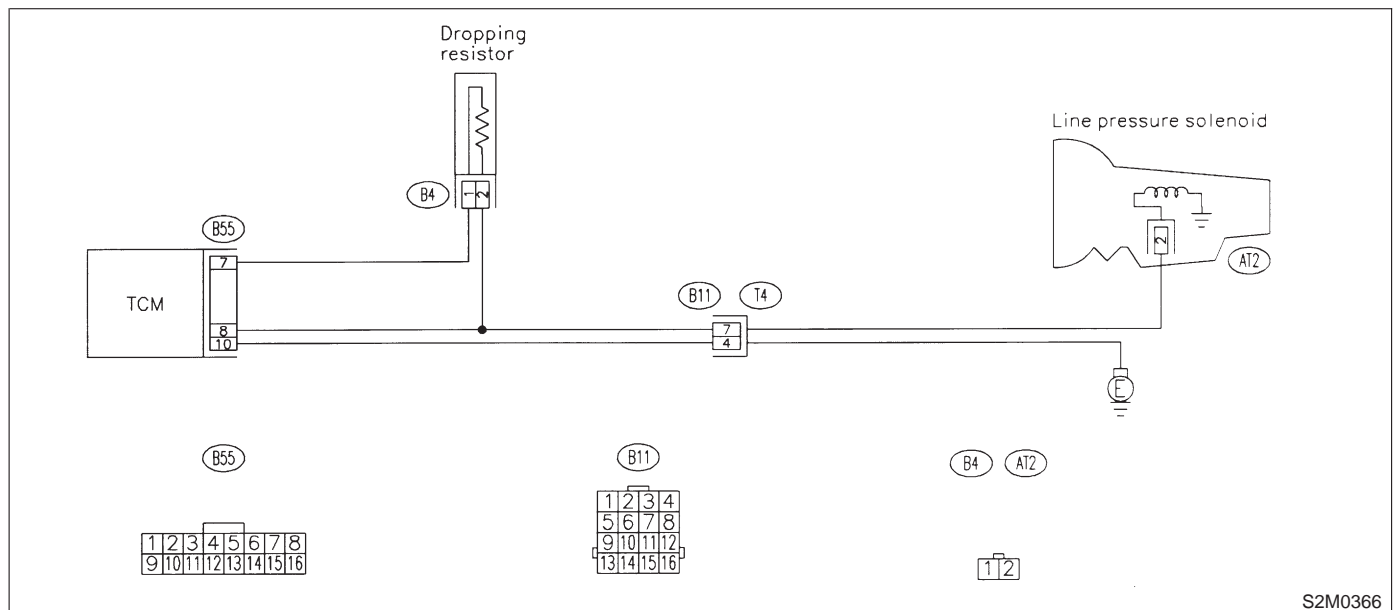

S2M0366

3-2 [T8C1] AUTOMATIC TRANSMISSION AND DIFFERENTIAL

8. Diagnostic Chart with Trouble Code

8C1 : CHECK RESISTOR.

- 1) Turn ignition switch to OFF.
- 2) Disconnect connector from dropping resistor.
- 3) Measure resistance between dropping resistor terminal.

Terminals

(B4) No. 1 — No. 2:

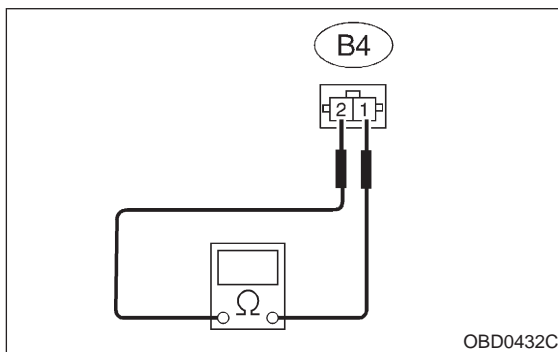

CHECK : Is the resistance between 9 and 15 Ω?

YES : Go to step 8C2.

NO : Replace dropping resistor.

8C2 : CHECK HARNESS CONNECTOR BETWEEN TCM AND DROPPING RESISTOR.

- 1) Disconnect connector from TCM.
- 2) Measure resistance of harness between TCM connector and dropping resistor connector.

Connector & terminal

(B55) No. 7 — (B4) No. 1:

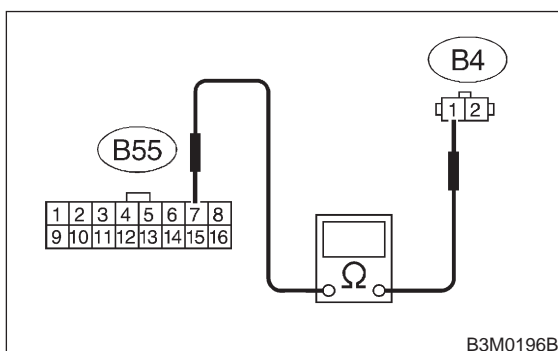

CHECK : Is the resistance less than 1 Ω?

YES : Go to step 8C3.

NO : Repair open circuit in harness between TCM and dropping resistor connector.

8C3 : CHECK HARNESS CONNECTOR BETWEEN TCM AND DROPPING RESISTOR.

Measure resistance of harness between dropping resistor connector and chassis ground.

Connector & terminal

(B4) No. 1 — Chassis ground:

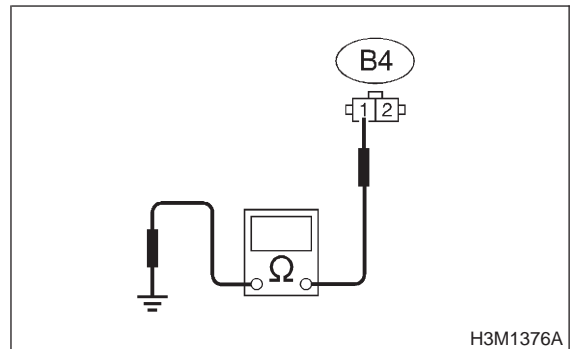

CHECK : Is the resistance more than 1 MΩ?

YES : Go to step 8C4.

NO : Repair short circuit in harness between TCM and dropping resistor connector.

8C4 : CHECK HARNESS CONNECTOR BETWEEN TRANSMISSION AND DROPPING RESISTOR.

- 1) Remove air intake chamber.
- 2) Disconnect connector from transmission.
- 3) Measure resistance of harness between transmission and dropping resistor connector.

Connector & terminal

(B4) No. 2 — (B11) No. 7:

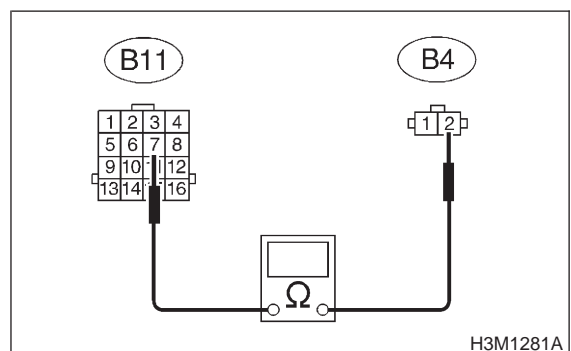

CHECK : Is the resistance less than 1 Ω?

YES : Go to step 8C5.

NO : Repair open circuit in harness between dropping resistor and transmission connector.

8C5 : CHECK HARNESS CONNECTOR BETWEEN TRANSMISSION AND DROPPING RESISTOR.

Measure resistance of harness between dropping resistor connector and chassis ground.

Connector & terminal
(B4) No. 2 — Chassis ground:

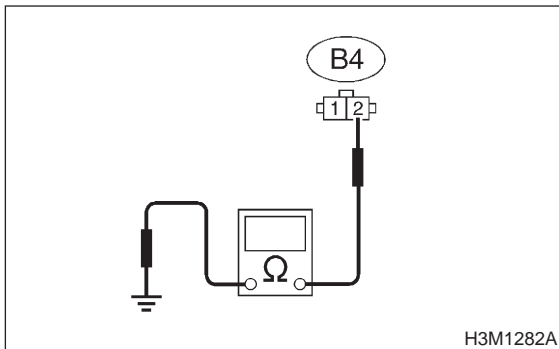

- CHECK** : *Is the resistance more than 1 MΩ?*
- YES** : Go to step **8C6**.
- NO** : Repair short circuit in harness between dropping resistor and transmission connector.

8C6 : CHECK DUTY SOLENOID A GROUND LINE.

Measure resistance between transmission connector and transmission ground.

Connector & terminal
(T4) No. 4 — Transmission ground:

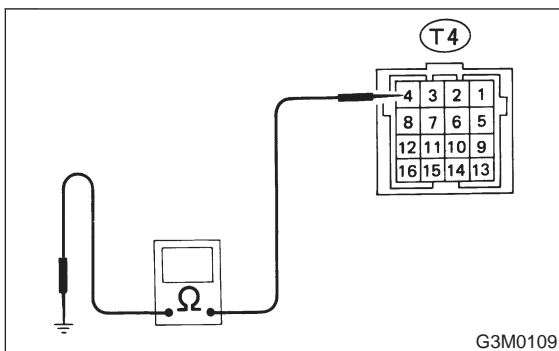

- CHECK** : *Is the resistance less than 1 Ω?*
- YES** : Go to step **8C7**.
- NO** : Repair open circuit in transmission harness.

8C7 : CHECK DUTY SOLENOID A.

Measure resistance between transmission connector receptacle's terminals.

Terminal
(T4) No. 7 — No. 4:

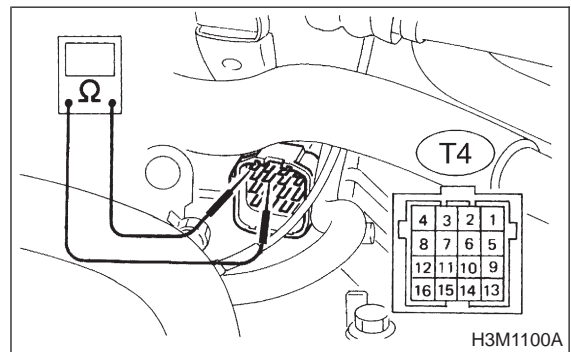

- CHECK** : *Is the resistance between 1.5 and 4.5 Ω?*
- YES** : Go to step **8C8**.
- NO** : Go to step **8C20**.

8C8 : CHECK HARNESS CONNECTOR BETWEEN TCM AND TRANSMISSION.

Measure resistance of harness between TCM and transmission connector.

Connector & terminal
(B55) No. 8 — (B11) No. 7:

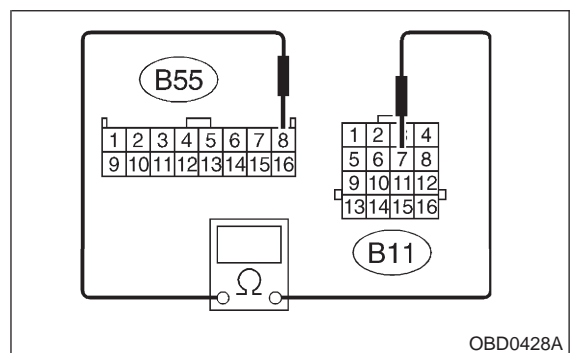

- CHECK** : *Is the resistance less than 1 Ω?*
- YES** : Go to step **8C9**.
- NO** : Repair open circuit in harness between TCM and transmission connector.

3-2 [T8C9] AUTOMATIC TRANSMISSION AND DIFFERENTIAL

8. Diagnostic Chart with Trouble Code

8C9 : CHECK HARNESS CONNECTOR BETWEEN TCM AND TRANSMISSION.

Measure resistance of harness between TCM and transmission connector.

Connector & terminal

(B55) No. 10 — (B11) No. 4:

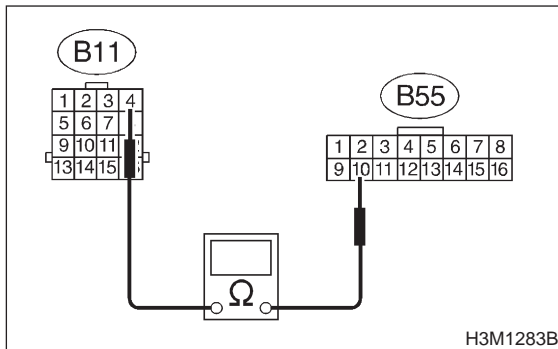

- CHECK** : Is the resistance less than 1 Ω?
- YES** : Go to step 8C10.
- NO** : Repair open circuit in harness between TCM and transmission connector.

8C10 : CHECK HARNESS CONNECTOR BETWEEN TCM AND CHASSIS GROUND.

Measure resistance of harness between TCM and chassis ground.

Connector & terminal

(B55) No. 8 — Chassis ground:

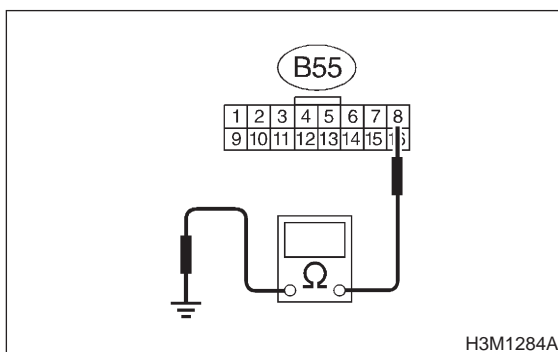

- CHECK** : Is the resistance more than 1 MΩ?
- YES** : Go to step 8C11.
- NO** : Repair short circuit in harness between TCM and transmission connector.

8C11 : PREPARE SUBARU SELECT MONITOR.

- CHECK** : Do you have a Subaru Select Monitor?
- YES** : Go to step 8C17.
- NO** : Go to step 8C12.

8C12 : CHECK HARNESS CONNECTOR BETWEEN TCM AND CHASSIS GROUND.

Measure resistance of harness between TCM and chassis ground.

Connector & terminal

(B55) No. 10 — Chassis ground:

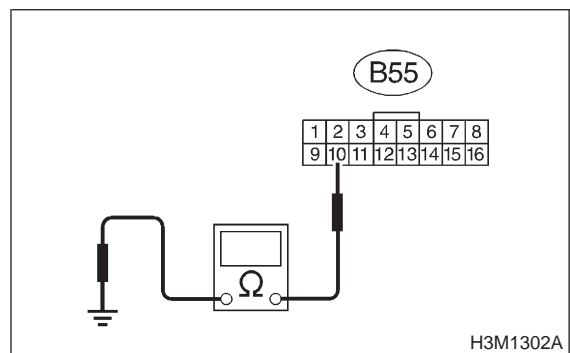

- CHECK** : Is the resistance more than 1 MΩ?
- YES** : Go to step 8C13.
- NO** : Repair short circuit harness between TCM and transmission connector.

8C13 : CHECK OUTPUT SIGNAL EMITTED FROM TCM.

- 1) Connect connectors to TCM, transmission and dropping resistor.
- 2) Start the engine and warm-up the transmission until ATF temperature is above 80°C (176°F).

NOTE:

If ambient temperature is below 0°C (32°F), drive the vehicle until the ATF reaches its operating temperature.

- 3) Turn ignition switch to ON (engine OFF).
- 4) Move selector lever to "N".
- 5) Measure voltage between TCM connector terminal.

Connector & terminal

(B55) No. 8 (+) — No. 10 (-):

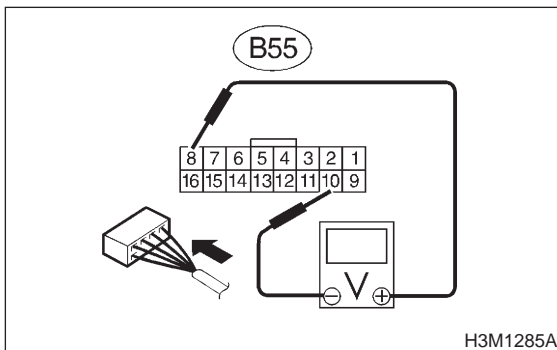

CHECK : **Is the voltage between 1.5 and 4.0 V with throttle fully closed?**

YES : Go to step **8C14**.

NO : Go to step **8C19**.

8C14 : CHECK OUTPUT SIGNAL EMITTED FROM TCM.

Measure voltage between TCM connector terminal.

Connector & terminal

(B55) No. 8 (+) — No. 10 (-):

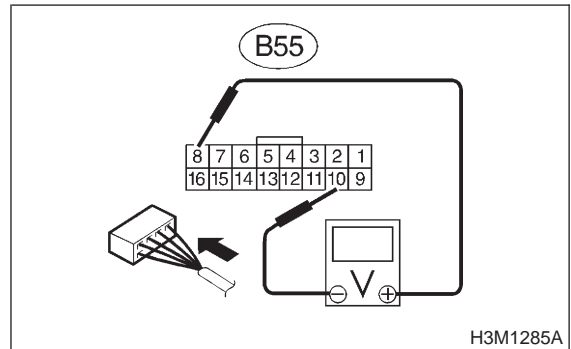

CHECK : **Is the voltage less than 1 V with throttle fully open?**

YES : Go to step **8C15**.

NO : Go to step **8C19**.

8C15 : CHECK OUTPUT SIGNAL EMITTED FROM TCM.

Measure voltage between TCM connector terminal.

Connector & terminal

(B55) No. 7 (+) — No. 10 (-):

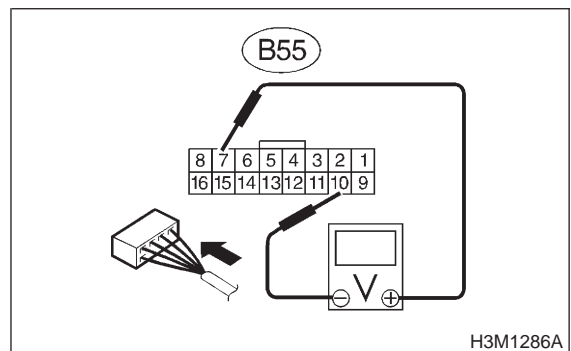

CHECK : **Is the voltage more than 8.5 V with throttle fully closed?**

YES : Go to step **8C16**.

NO : Go to step **8C19**.

3-2 [T8C16] AUTOMATIC TRANSMISSION AND DIFFERENTIAL

8. Diagnostic Chart with Trouble Code

8C16 : CHECK OUTPUT SIGNAL EMITTED FROM TCM.

Measure voltage between TCM connector terminal.

Connector & terminal

(B55) No. 7 (+) — No. 10 (-):

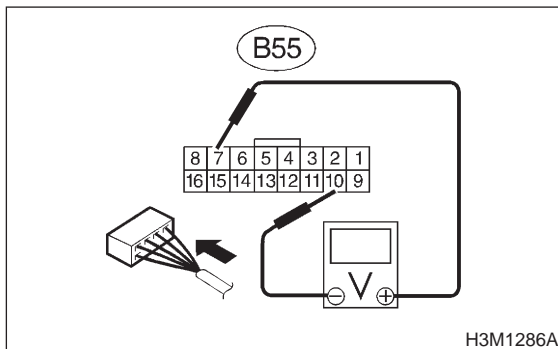

CHECK : *Is the voltage less than 1 V with throttle fully open?*

YES : Even if "AT OIL TEMP" lights up, the circuit has returned to a normal condition at this time. A temporary poor contact of the connector or harness may be the cause. Repair harness or connector in TCM.

NO : Go to step **8C19**.

8C17 : CHECK OUTPUT SIGNAL EMITTED FROM TCM USING SUBARU SELECT MONITOR.

- 1) Connect connectors to TCM and transmission.
- 2) Connect Subaru Select Monitor to data link connector.

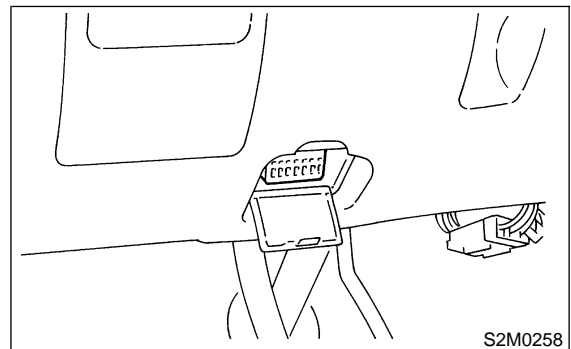

- 3) Start the engine, and turn Subaru Select Monitor switch to ON.
- 4) Warm-up the transmission until ATF temperature is above 80°C (176°F).

NOTE:

If ambient temperature is below 0°C (32°F), drive the vehicle until the ATF reaches its operating temperature.

- 5) Stop the engine and turn ignition switch to ON (engine OFF).
- 6) Move selector lever to "N".
- 7) Read data of duty solenoid A using Subaru Select Monitor.
 - Line pressure duty is indicated in "%".
- 8) Throttle is fully closed.

CHECK : *Is the value 100%?*

YES : Go to step **8C18**.

NO : Go to step **8C19**.

8C18 : CHECK OUTPUT SIGNAL EMITTED FROM TCM USING SUBARU SELECT MONITOR.

- 1) Turn ignition switch to ON (Engine OFF).
- 2) Throttle is fully open.

CHECK : *Is the value between 10 and 20%?*

YES : Even if "AT OIL TEMP" lights up, the circuit has returned to a normal condition at this time. A temporary poor contact of the connector or harness may be the cause. Repair harness or connector in TCM.

NO : Go to step **8C19**.

8C19 : CHECK POOR CONTACT.

- CHECK** : *Is there poor contact in duty solenoid A circuit?*
- YES** : Repair poor contact.
- NO** : Replace TCM.

8C20 : CHECK DUTY SOLENOID A (IN TRANSMISSION).

- 1) Remove transmission connector from bracket.
- 2) Drain automatic transmission fluid.

CAUTION:
Do not drain the automatic transmission fluid until it cools down.

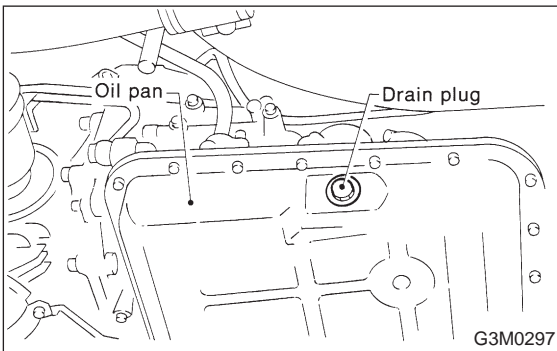

- 3) Remove oil pan, and disconnect connector from duty solenoid A.
- 4) Measure resistance between duty solenoid A connector and transmission ground.

Connector & terminal
(AT2) No. 2 — Transmission ground:

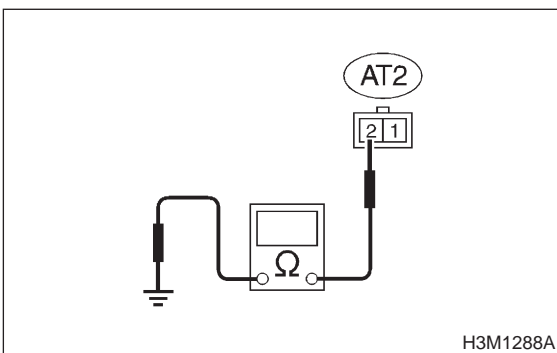

- CHECK** : *Is the resistance between 1.5 and 4.5 Ω?*
- YES** : Go to step **8C21**.
- NO** : Replace duty solenoid A.

8C21 : CHECK HARNESS CONNECTOR BETWEEN TRANSMISSION AND DUTY SOLENOID A.

Measure resistance of harness between duty solenoid A and transmission connector.

Connector & terminal
(T4) No. 7 — (AT2) No. 2:

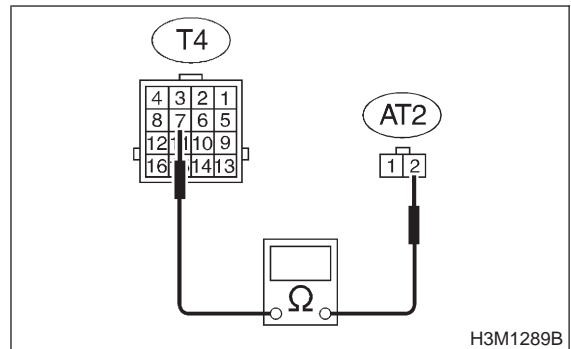

- CHECK** : *Is the resistance less than 1 Ω?*
- YES** : Go to step **8C22**.
- NO** : Repair open circuit in harness between duty solenoid A and transmission connector.

3-2 [T8C22] AUTOMATIC TRANSMISSION AND DIFFERENTIAL

8. Diagnostic Chart with Trouble Code

8C22 : CHECK HARNESS CONNECTOR BETWEEN TRANSMISSION AND DUTY SOLENOID A.

Measure resistance of harness between transmission connector and transmission ground.

Connector & terminal

(T4) No. 7 — Transmission ground:

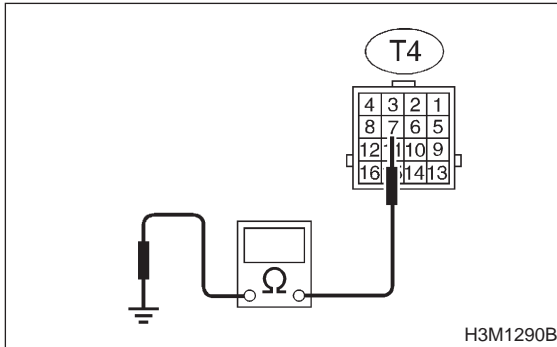

- CHECK** : **Is the resistance more than 1 MΩ?**
- YES** : Even if "AT OIL TEMP" lights up, the circuit has returned to a normal condition at this time. A temporary poor contact of the connector or harness may be the cause. Repair harness or connector in duty solenoid A and transmission connector.
- NO** : Repair short circuit in harness between duty solenoid A and transmission connector.

MEMO:

3-2 [T8D0] AUTOMATIC TRANSMISSION AND DIFFERENTIAL

8. Diagnostic Chart with Trouble Code

D: TROUBLE CODE 12 — DUTY SOLENOID B —

DIAGNOSIS:

Output signal circuit of duty solenoid B is open or shorted.

TROUBLE SYMPTOM:

No "lock-up" (after engine warm-up).

WIRING DIAGRAM:

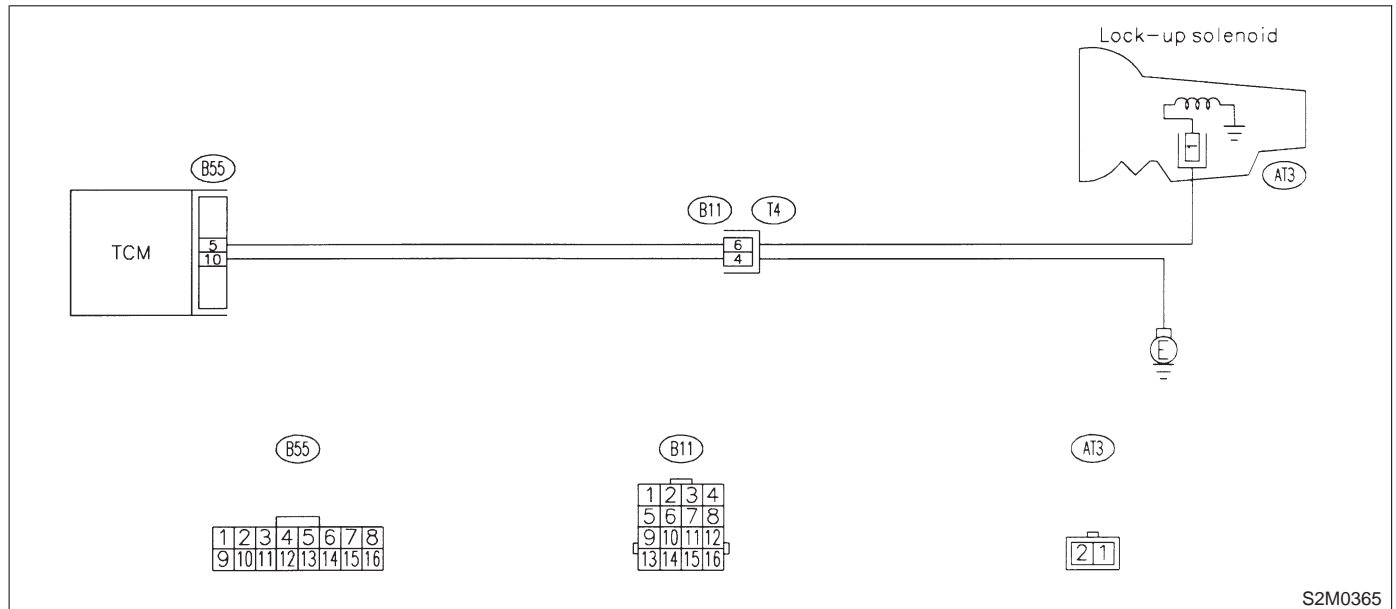

S2M0365

8D1 : CHECK TROUBLE CODE.

- CHECK** : *Do multiple trouble codes appear in the on-board diagnostics test mode?*
- YES** : Go to another trouble code.
- NO** : Go to step **8D2**.

8D2 : CHECK DUTY SOLENOID B GROUND LINE.

- 1) Turn ignition switch to OFF.
- 2) Remove air intake chamber.
- 3) Disconnect connector from transmission.
- 4) Measure resistance between transmission connector receptacle's terminals.

Connector & terminal
(T4) No. 4 — Chassis ground:

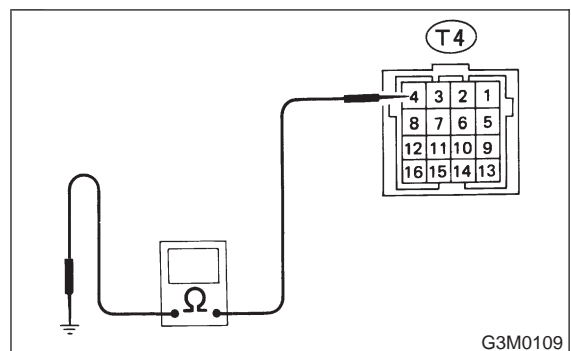

G3M0109

- CHECK** : *Is the resistance less than 1 Ω?*
- YES** : Go to step **8D3**.
- NO** : Repair open circuit in transmission harness.

8D3 : CHECK DUTY SOLENOID B.

Measure resistance between transmission connector receptacle's terminals.

Connector & terminal
(T4) No. 6 — No. 4:

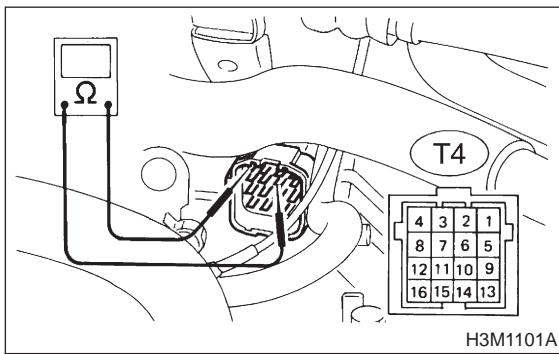

- CHECK** : *Is the resistance less than 1 Ω?*
- YES** : Go to step **8D4**.
- NO** : Go to step **8D14**.

8D4 : CHECK HARNESS CONNECTOR BETWEEN TCM AND TRANSMISSION.

- 1) Disconnect connector from TCM.
- 2) Measure resistance of harness between TCM and transmission connector.

Connector & terminal
(B55) No. 10 — (B11) No. 4:

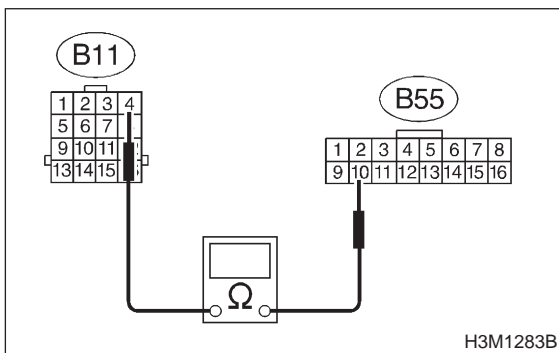

- CHECK** : *Is the resistance than 1 Ω?*
- YES** : Go to step **8D5**.
- NO** : Repair open circuit in harness between TCM and transmission connector.

8D5 : CHECK HARNESS CONNECTOR BETWEEN TCM AND TRANSMISSION.

Measure resistance of harness connector between TCM and transmission.

Connector & terminal
(B55) No. 5 — (B11) No. 6:

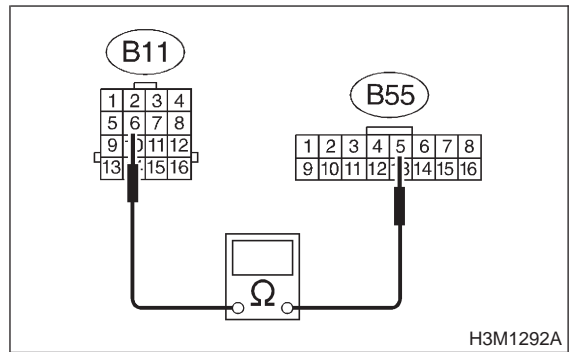

- CHECK** : *Is the resistance less than 1 Ω?*
- YES** : Go to step **8D6**.
- NO** : Repair open circuit in harness between TCM and transmission connector.

8D6 : CHECK HARNESS CONNECTOR BETWEEN TCM AND TRANSMISSION.

Measure resistance of harness connector between TCM and chassis ground.

Connector & terminal
(B55) No. 5 — Chassis ground:

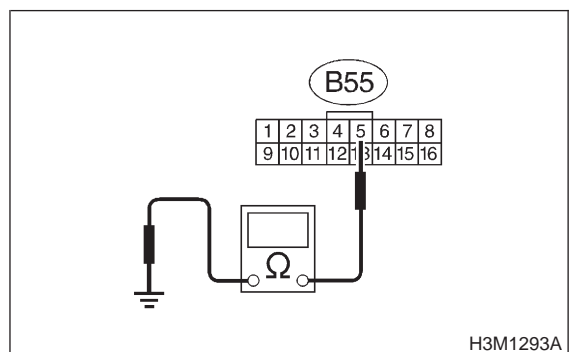

- CHECK** : *Is the resistance more than 1 MΩ?*
- YES** : Go to step **8D7**.
- NO** : Repair short circuit in harness between TCM and transmission connector.

3-2 [T8D7] AUTOMATIC TRANSMISSION AND DIFFERENTIAL

8. Diagnostic Chart with Trouble Code

8D7 : CHECK HARNESS CONNECTOR BETWEEN TCM AND TRANSMISSION.

Measure resistance of harness connector between TCM and chassis ground.

Connector & terminal

(B55) No. 10 — Chassis ground:

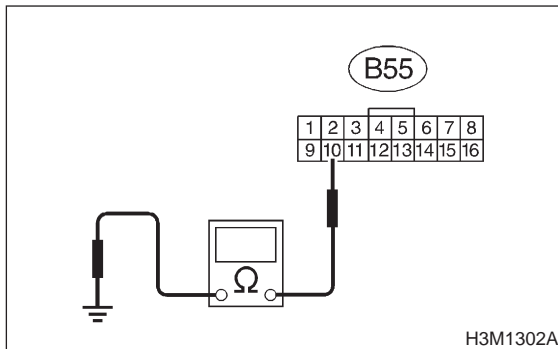

- CHECK** : Is the resistance more than 1 MΩ?
- YES** : Go to step 8D8.
- NO** : Repair short circuit in harness between TCM and transmission connector.

8D8 : PREPARE SUBARU SELECT MONITOR.

- CHECK** : Do you have a Subaru Select Monitor?
- YES** : Go to step 8D11.
- NO** : Go to step 8D9.

8D9 : CHECK OUTPUT SIGNAL EMITTED FROM TCM.

- 1) Connect connectors to TCM and transmission.
- 2) Install air intake chamber.
- 3) Lift-up the vehicle and place safety stand.

CAUTION:

On AWD models, raise all wheels off ground.

- 4) Start the engine and warm-up the transmission until ATF temperature is above 80°C (176°F).

NOTE:

If ambient temperature is below 0°C (32°F), drive the vehicle until the ATF reaches its operating temperature.

- 5) Move selector lever to “D” and slowly increase vehicle speed to 75 km/h (47 m/h). Wheels will lock-up.

NOTE:

The speed difference between front and rear wheels may light the ABS warning light, but this indicates no malfunction. When AT control diagnosis is finished, perform the ABS memory clearance procedure of on-board diagnostics system. <Ref. to 4-4 [T6D2].>

- 6) Measure voltage between TCM connector terminals.

Connector & terminal

(B55) No. 5 (+) — No. 10 (-):

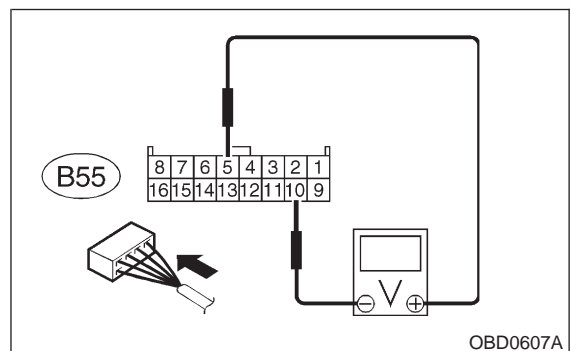

- CHECK** : Is the voltage more than 8.5 V?
- YES** : Go to step 8D10.
- NO** : Go to step 8D13.

8D10 : CHECK OUTPUT SIGNAL EMITTED FROM TCM.

- 1) Return the engine to idling speed and move selector lever to "N".
- 2) Measure voltage between TCM connector terminals.

Connector & terminal

(B55) No. 5 (+) — No. 10 (-):

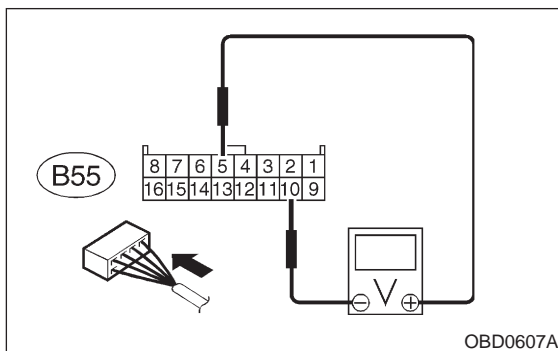

- CHECK** : **Is the voltage less than 0.5 V?**
- YES** : Even if "AT OIL TEMP" lights up, the circuit has returned to a normal condition at this time. A temporary poor contact of the connector or harness may be the cause. Repair harness or connector in TCM.
- NO** : Go to step **8D13**.

8D11 : CHECK OUTPUT SIGNAL EMITTED FROM TCM USING SUBARU SELECT MONITOR.

- 1) Connect connectors to TCM and transmission.
- 2) Install air intake chamber.
- 3) Lift-up the vehicle and place safety stand.

CAUTION:

On AWD models, raise all wheels off ground.

- 4) Connect Subaru Select Monitor to data link connector.

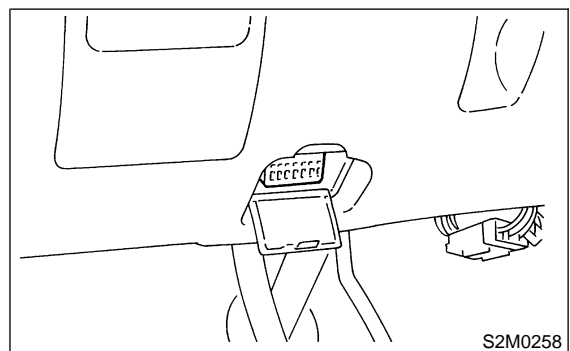

- 5) Start the engine, and turn Subaru Select Monitor switch to ON.
- 6) Start the engine and warm-up the transmission until ATF temperature is above 80°C (176°F).

NOTE:

If ambient temperature is below 0°C (32°F), drive the vehicle until the ATF reaches its operating temperature.

- 7) Read data of duty solenoid B using Subaru Select Monitor.

● Lock-up duty is indicated in "%".

- 8) Move selector lever to "D" and slowly increase vehicle speed to 75 km/h (47 m/h). Wheels will lock-up.

NOTE:

The speed difference between front and rear wheels may light the ABS warning light, but this indicates no malfunction. When AT control diagnosis is finished, perform the ABS memory clearance procedure of on-board diagnostics system. <Ref. to 4-4 [T6D2].>

- CHECK** : **Is the value 95%?**
- YES** : Go to step **8D12**.
- NO** : Go to step **8D13**.

3-2 [T8D12] AUTOMATIC TRANSMISSION AND DIFFERENTIAL

8. Diagnostic Chart with Trouble Code

8D12 : CHECK OUTPUT SIGNAL EMITTED FROM TCM USING SUBARU SELECT MONITOR.

Return the engine to idling speed and move selector lever to "N".

NOTE:

The speed difference between front and rear wheels may light the ABS warning light, but this indicates no malfunction. When AT control diagnosis is finished, perform the ABS memory clearance procedure of on-board diagnostics system. <Ref. to 4-4 [T6D2].>

CHECK : *Is the value 5%?*

YES : Even if "AT OIL TEMP" lights up, the circuit has returned to a normal condition at this time. A temporary poor contact of the connector or harness may be the cause. Repair harness or connector in TCM.

NO : Go to step **8D13**.

8D13 : CHECK POOR CONTACT.

CHECK : *Is there poor contact in duty solenoid B circuit?*

YES : Repair poor contact.

NO : Replace TCM.

8D14 : CHECK DUTY SOLENOID B (IN TRANSMISSION).

- 1) Remove transmission connector from bracket.
- 2) Drain automatic transmission fluid.

CAUTION:

Do not drain the automatic transmission fluid until it cools down.

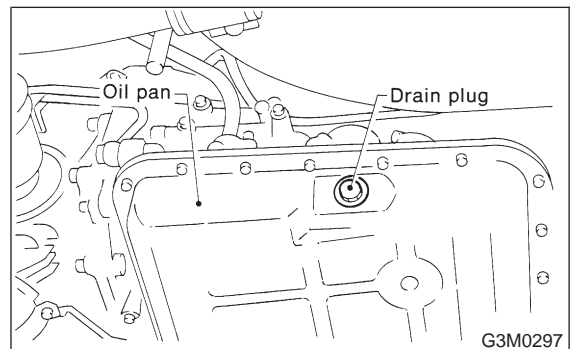

- 3) Remove oil pan, and disconnect connector from duty solenoid B.
- 4) Measure resistance between duty solenoid B connector and transmission ground.

Connector & terminal

(AT3) No. 1 — Transmission ground:

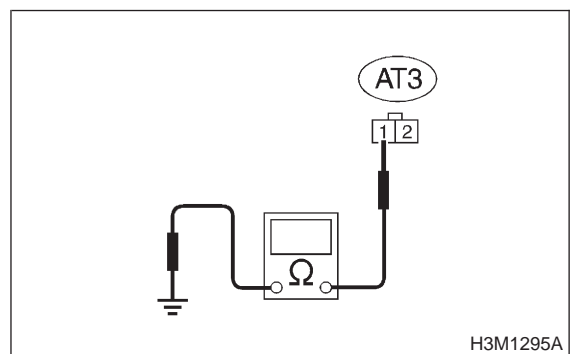

CHECK : *Is the resistance between 9 and 17 Ω?*

YES : Go to step **8D15**.

NO : Replace duty solenoid B.

8D15 : CHECK HARNESS CONNECTOR BETWEEN DUTY SOLENOID B AND TRANSMISSION.

Measure resistance of harness between duty solenoid B and transmission connector.

Connector & terminal
(T4) No. 6 — (AT3) No. 1:

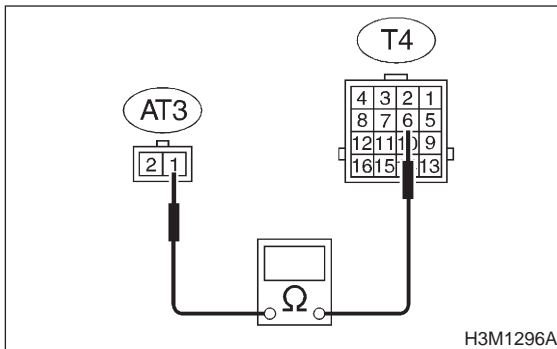

- CHECK** : **Is the resistance less than 1 Ω?**
- YES** : Go to step **8D16**.
- NO** : Repair open circuit in harness between TCM and transmission connector.

8D16 : CHECK HARNESS CONNECTOR BETWEEN DUTY SOLENOID B AND TRANSMISSION.

Measure resistance of harness between transmission connector and transmission ground.

Connector & terminal
(T4) No. 6 — Transmission ground:

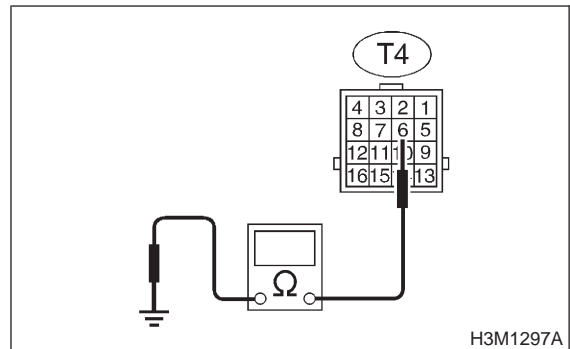

- CHECK** : **Is the resistance more than 1 MΩ?**
- YES** : Even if “AT OIL TEMP” lights up, the circuit has returned to a normal condition at this time. A temporary poor contact of the connector or harness may be the cause. Repair harness or connector in duty solenoid B and transmission.
- NO** : Repair short circuit in harness between TCM and transmission connector.

3-2 [T8E0] AUTOMATIC TRANSMISSION AND DIFFERENTIAL

8. Diagnostic Chart with Trouble Code

E: TROUBLE CODE 13 — SHIFT SOLENOID 3 —

DIAGNOSIS:

Output signal circuit of shift solenoid 3 is open or shorted.

TROUBLE SYMPTOM:

Ineffective engine brake with shift lever in "3".

WIRING DIAGRAM:

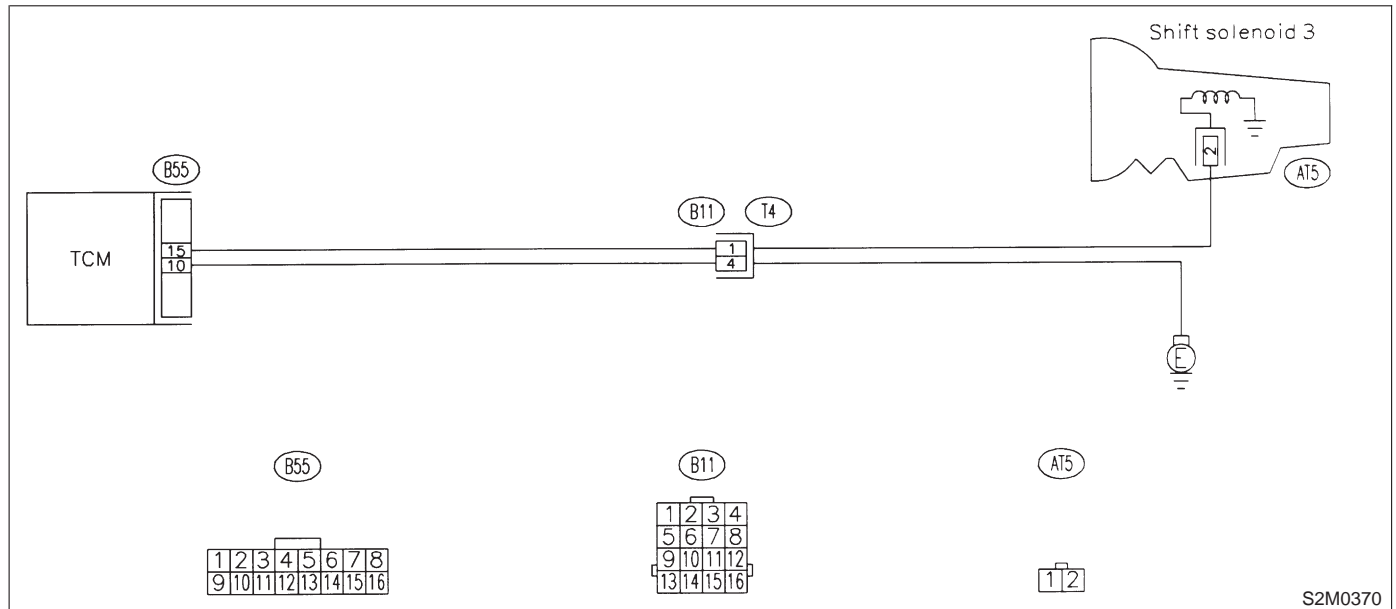

8E1 : CHECK SHIFT SOLENOID 3 GROUND LINE.

- 1) Turn ignition switch to OFF.
- 2) Remove air intake chamber.
- 3) Disconnect connector from transmission.
- 4) Measure resistance between transmission connector and transmission ground.

Connector & terminal

(T4) No. 4 — Chassis ground:

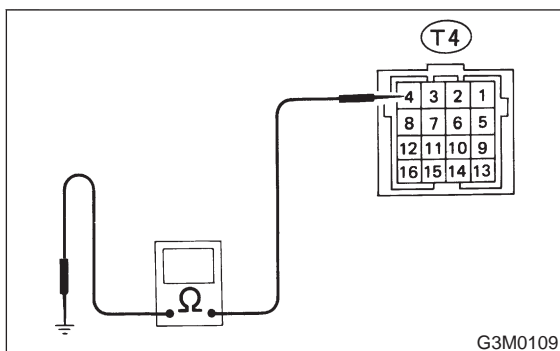

- CHECK** : Is the resistance less than 1 Ω?
- YES** : Go to step 8E2.
- NO** : Repair open circuit in transmission harness.

8E2 : CHECK SHIFT SOLENOID 3.

Measure resistance between transmission connector terminals.

Connector & terminal

(T4) No. 1 — No. 4:

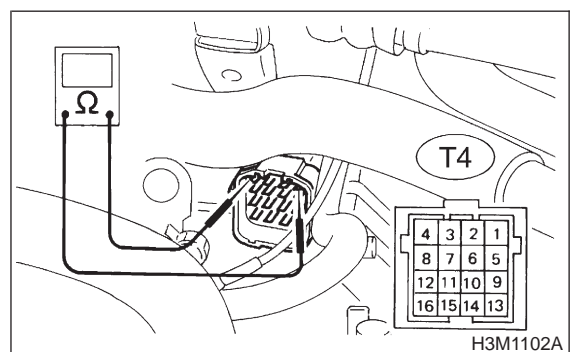

- CHECK** : Is the resistance between 20 and 32 Ω?
- YES** : Go to step 8E3.
- NO** : Go to step 8E10.

8E3 : CHECK HARNESS CONNECTOR BETWEEN TCM AND TRANSMISSION.

- 1) Disconnect connector from TCM.
- 2) Measure resistance of harness between TCM and transmission connector.

Connector & terminal
(B55) No. 15 — (B11) No. 1:

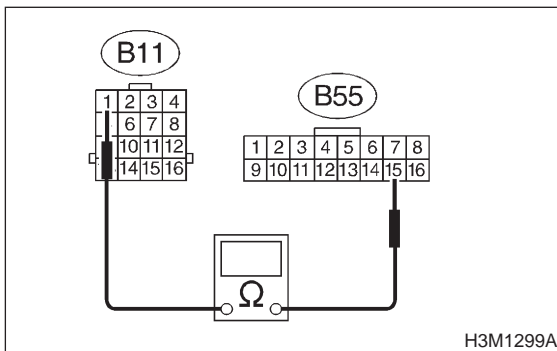

- CHECK** : Is the resistance less than 1 Ω?
- YES** : Go to step 8E4.
- NO** : Repair open circuit in harness between TCM and transmission connector.

8E4 : CHECK HARNESS CONNECTOR BETWEEN TCM AND TRANSMISSION.

Measure resistance of harness between TCM and transmission connector.

Connector & terminal
(B55) No. 10 — (B11) No. 4:

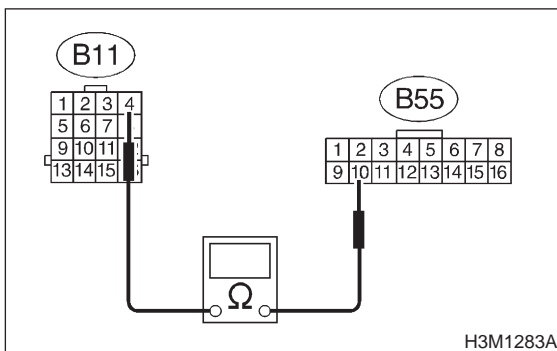

- CHECK** : Is the resistance less than 1 Ω?
- YES** : Go to step 8E5.
- NO** : Repair open circuit in harness between TCM and transmission connector.

8E5 : CHECK HARNESS CONNECTOR BETWEEN TCM AND TRANSMISSION.

Measure resistance of harness between TCM connector and transmission ground.

Connector & terminal
(B55) No. 15 — Chassis ground:

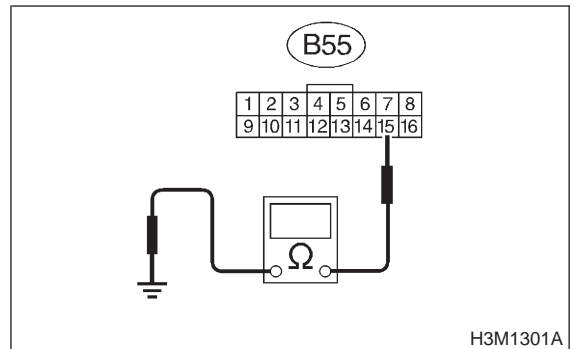

- CHECK** : Is the resistance more than 1 MΩ?
- YES** : Go to step 8E6.
- NO** : Repair short circuit in harness between TCM and transmission connector.

8E6 : CHECK HARNESS CONNECTOR BETWEEN TCM AND TRANSMISSION.

Measure resistance of harness between TCM connector and transmission ground.

Connector & terminal
(B55) No. 10 — Chassis ground:

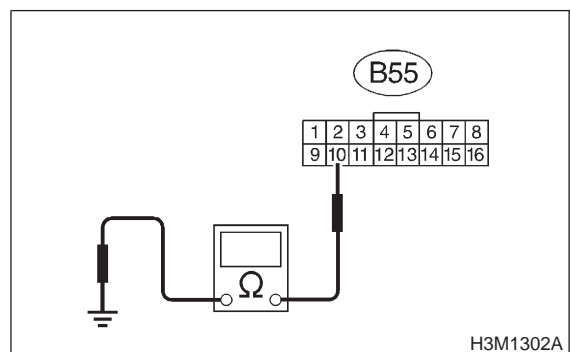

- CHECK** : Is the resistance more than 1 MΩ?
- YES** : Go to step 8E7.
- NO** : Repair short circuit in harness between TCM and transmission connector.

3-2 [T8E7] AUTOMATIC TRANSMISSION AND DIFFERENTIAL

8. Diagnostic Chart with Trouble Code

8E7 : CHECK OUTPUT SIGNAL EMITTED FROM TCM.

- 1) Connect connectors to TCM and transmission.
- 2) Install air intake chamber.
- 3) Lift-up or raise the vehicle and support with safety stand.

CAUTION:

On AWD models, raise all wheels off ground.

- 4) Start the engine and warm-up the transmission until ATF temperature is above 80°C (176°F).

NOTE:

If ambient temperature is below 0°C (32°F), drive the vehicle until the ATF reaches its operating temperature.

- 5) Move selector lever to "2", and slowly increase vehicle speed to 35 km/h (22 m/h).

NOTE:

The speed difference between front and rear wheels may light the ABS warning light, but this indicates no malfunction. When AT control diagnosis is finished, perform the ABS memory clearance procedure of on-board diagnostics system. <Ref. to 4-4 [T6D2].>

- 6) Measure voltage between TCM connector terminals.

Connector & terminal

(B55) No. 15 (+) — No. 10 (-):

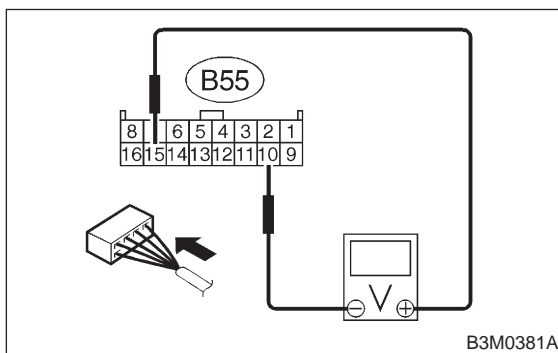

CHECK : Is the voltage less than 1 V?

YES : Go to step 8E8.

NO : Go to step 8E9.

8E8 : CHECK OUTPUT SIGNAL EMITTED FROM TCM.

- 1) Move selector lever to "D", and slowly increase vehicle speed to 65 km/h (41 m/h).

NOTE:

The speed difference between front and rear wheels may light the ABS warning light, but this indicates no malfunction. When AT control diagnosis is finished, perform the ABS memory clearance procedure of on-board diagnostics system. <Ref. to 4-4 [T6D2].>

- 2) Measure voltage between TCM connector terminals.

Connector & terminal

(B55) No. 15 (+) — No. 10 (-):

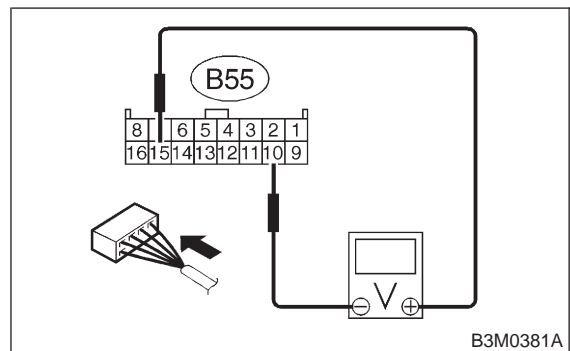

CHECK : Is the voltage more than 10 V?

YES : Even if "AT OIL TEMP" lights up, the circuit has returned to a normal condition at this time. A temporary poor contact of the connector or harness may be the cause. Repair harness or contact in the TCM.

NO : Go to step 8E9.

8E9 : CHECK POOR CONTACT.

CHECK : Is there poor contact in shift solenoid 3 circuit?

YES : Repair poor contact.

NO : Replace TCM.

8E10 : CHECK SHIFT SOLENOID 3 (IN TRANSMISSION).

- 1) Remove transmission connector from bracket.
- 2) Lift-up or raise the vehicle and support with safety stand.

CAUTION:
On AWD models, raise all wheels off ground.

- 3) Drain automatic transmission fluid.

CAUTION:
Do not drain the automatic transmission fluid until it cools down.

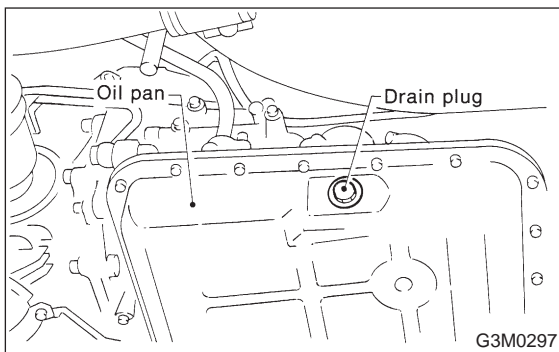

- 4) Remove oil pan, and disconnect connector from shift solenoid 3.
- 5) Measure resistance between shift solenoid 3 connector and transmission ground.

Connector & terminal
(AT5) No. 2 — Transmission ground:

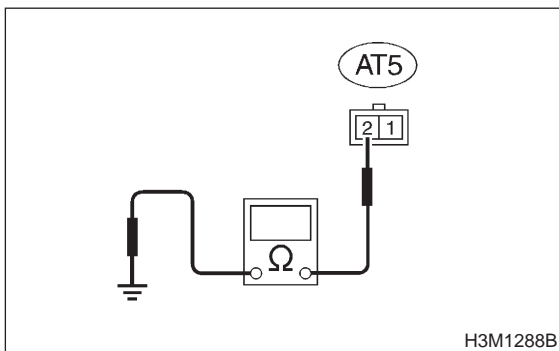

CHECK : Is the resistance between 20 and 32 Ω?

YES : Go to step 8E11.

NO : Replace shift solenoid assembly.

8E11 : CHECK HARNESS CONNECTOR BETWEEN SHIFT SOLENOID 3 AND TRANSMISSION.

Measure resistance of harness between shift solenoid 3 and transmission connector.

Connector & terminal
(AT5) No. 2 — (T4) No. 1:

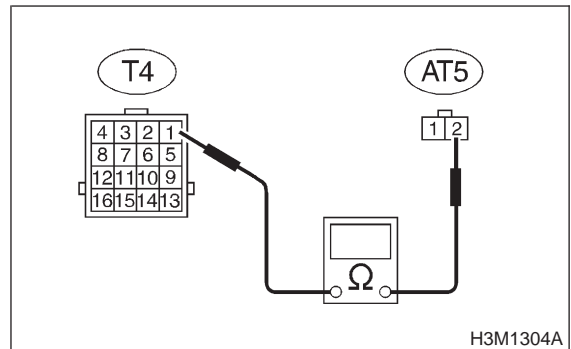

CHECK : Is the resistance less than 1 Ω?

YES : Go to step 8E12.

NO : Repair open circuit in harness between shift solenoid 3 and transmission connector.

3-2 [T8E12] AUTOMATIC TRANSMISSION AND DIFFERENTIAL

8. Diagnostic Chart with Trouble Code

8E12 : CHECK HARNESS CONNECTOR BETWEEN SHIFT SOLENOID 3 AND TRANSMISSION.

Measure resistance of harness between shift solenoid 3 connector and transmission ground.

Connector & terminal

(T4) No. 1 — Transmission ground:

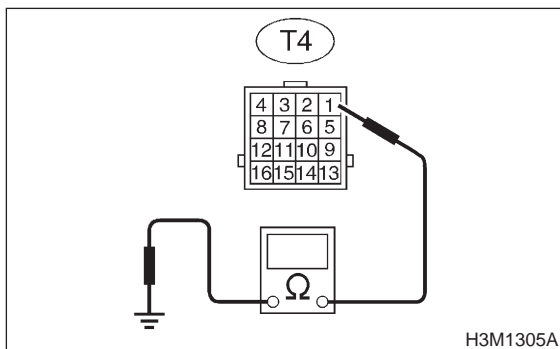

- CHECK** : **Is the resistance more than 1 M Ω ?**
- YES** : Even if "AT OIL TEMP" lights up, the circuit has returned to a normal condition at this time. A temporary poor contact of the connector or harness may be the cause. Repair harness or connector in shift solenoid 3 and transmission.
- NO** : Repair short circuit harness between TCM and transmission connector.

MEMO:

3-2 [T8F0] AUTOMATIC TRANSMISSION AND DIFFERENTIAL

8. Diagnostic Chart with Trouble Code

F: TROUBLE CODE 14 — SHIFT SOLENOID 2 —

DIAGNOSIS:

Output signal circuit of shift solenoid 2 is open or shorted.

TROUBLE SYMPTOM:

Does not shift.

WIRING DIAGRAM:

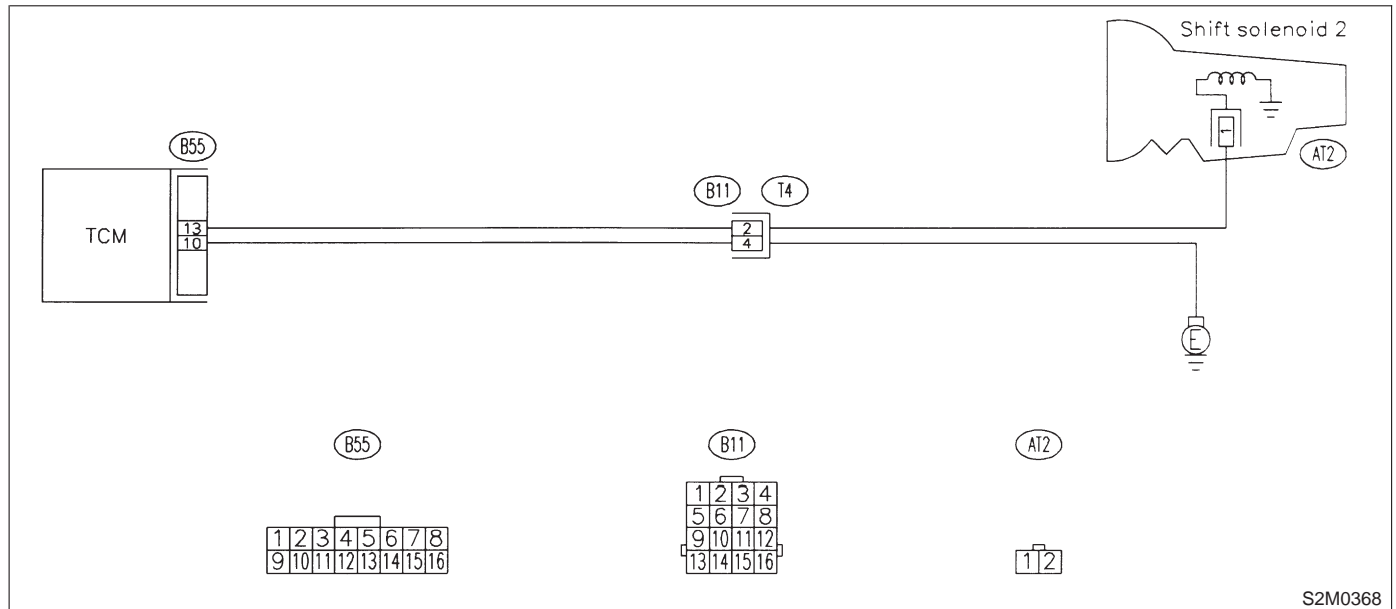

S2M0368

8F1 : CHECK SHIFT SOLENOID 2 GROUND LINE.

- 1) Turn ignition switch to OFF.
- 2) Remove air intake chamber.
- 3) Disconnect connector from transmission.
- 4) Measure resistance between transmission connector and transmission ground.

Connector & terminal

(T4) No. 4 — Chassis ground:

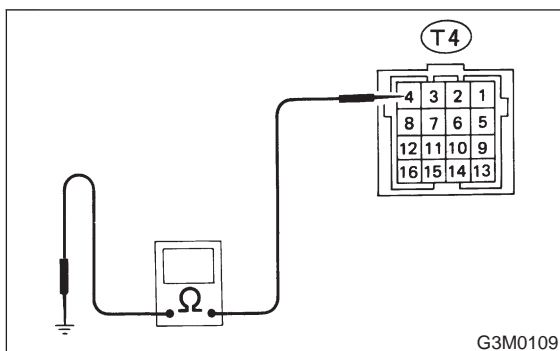

G3M0109

- CHECK** : Is the resistance less than 1 Ω?
- YES** : Go to step 8F2.
- NO** : Repair open circuit in transmission harness.

8F2 : CHECK SHIFT SOLENOID 2.

Measure resistance between transmission connector terminals.

Connector & terminal

(T4) No. 2 — No. 4:

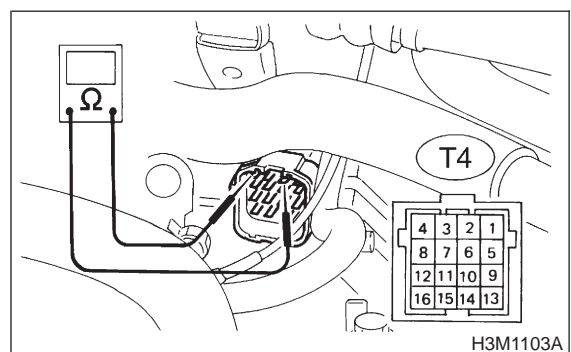

H3M1103A

- CHECK** : Is the resistance between 20 and 32 Ω?
- YES** : Go to step 8F3.
- NO** : Go to step 8F9.

8F3 : CHECK HARNESS CONNECTOR BETWEEN TCM AND TRANSMISSION.

- 1) Disconnect connector from TCM.
- 2) Measure resistance of harness between TCM and shift solenoid 2 connector.

Connector & terminal

(B55) No. 13 — (B11) No. 2:

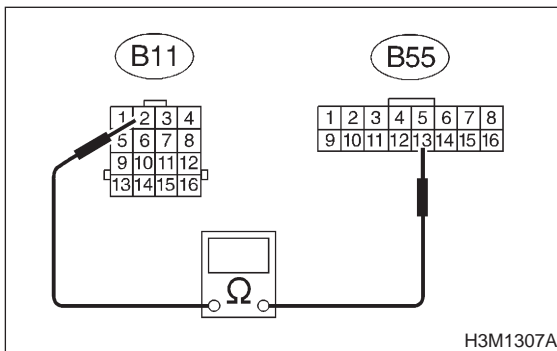

- CHECK** : *Is the resistance less than 1 Ω?*
- YES** : Go to step **8F4**.
- NO** : Repair open circuit in harness between TCM and transmission connector.

8F4 : CHECK HARNESS CONNECTOR BETWEEN TCM AND TRANSMISSION.

Measure resistance of harness between TCM and shift solenoid 2 connector.

Connector & terminal

(B55) No. 10 — (B11) No. 4:

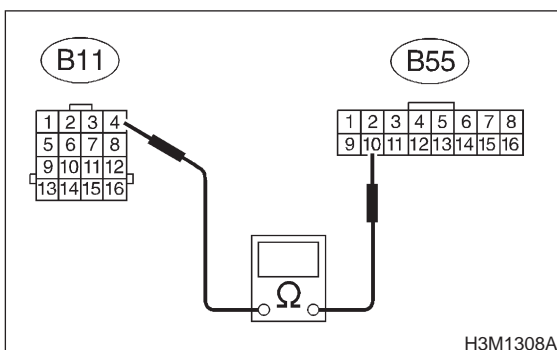

- CHECK** : *Is the resistance less than 1 Ω?*
- YES** : Go to step **8F5**.
- NO** : Repair open circuit in harness between TCM and transmission connector.

8F5 : CHECK HARNESS CONNECTOR BETWEEN TCM AND TRANSMISSION.

Measure resistance of harness between TCM connector and transmission ground.

Connector & terminal

(B55) No. 13 — Chassis ground:

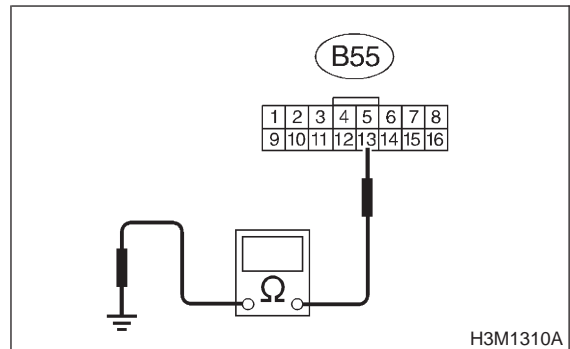

- CHECK** : *Is the resistance more than 1 MΩ?*
- YES** : Go to step **8F6**.
- NO** : Repair short circuit in harness between TCM and transmission connector.

8F6 : CHECK HARNESS CONNECTOR BETWEEN TCM AND TRANSMISSION.

Measure resistance of harness between TCM connector and transmission ground.

Connector & terminal

(B55) No. 10 — Chassis ground:

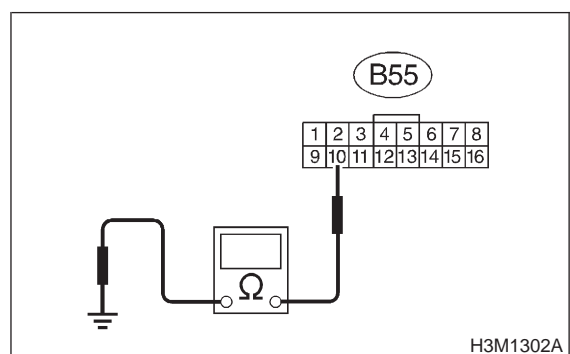

- CHECK** : *Is the resistance more than 1 MΩ?*
- YES** : Go to step **8F7**.
- NO** : Repair short circuit in harness between TCM and transmission connector.

3-2 [T8F7] AUTOMATIC TRANSMISSION AND DIFFERENTIAL

8. Diagnostic Chart with Trouble Code

8F7 : CHECK OUTPUT SIGNAL EMITTED FROM TCM.

- 1) Connect connectors to TCM and transmission.
- 2) Install air intake chamber.
- 3) Lift-up or raise the vehicle and support with safety stand.

CAUTION:

On AWD models, raise all wheels off ground.

- 4) Start the engine, and warm-up the transmission until ATF temperature is above 80°C (176°F).

NOTE:

If ambient temperature is below 0°C (32°F), drive the vehicle until the ATF reaches its operating temperature.

- 5) Move selector lever to "D", and slowly increase vehicle speed to 50 km/h (31 m/h).

NOTE:

The speed difference between front and rear wheels may light the ABS warning light, but this indicates no malfunction. When AT control diagnosis is finished, perform the ABS memory clearance procedure of on-board diagnostics system. <Ref. to 4-4 [T6D2].>

- 6) Measure voltage between TCM connector terminals.

Connector & terminal

(B55) No. 13 (+) — No. 10 (-):

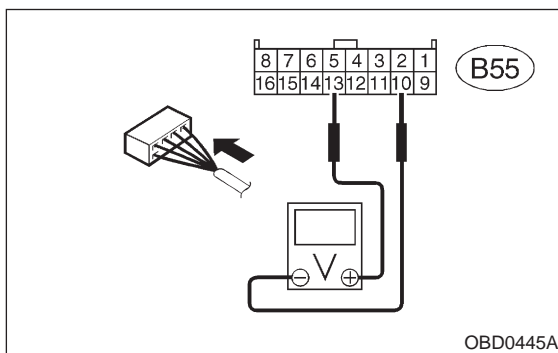

- CHECK** : **Is the voltage 9 V → 1 V?**
- YES** : Even if "AT OIL TEMP" lights up, the circuit has returned to a normal condition at this time. A temporary poor contact of the connector or harness may be the cause. Repair harness or contact in the TCM.
- NO** : Go to step **8F8**.

8F8 : CHECK POOR CONTACT.

- CHECK** : **Is there poor contact in shift solenoid 2 circuit?**
- YES** : Repair poor contact.
- NO** : Replace TCM.

8F9 : CHECK SHIFT SOLENOID 2 (IN TRANSMISSION).

- 1) Remove transmission connector from bracket.
- 2) Drain automatic transmission fluid.

CAUTION:

Do not drain the automatic transmission fluid until it cools down.

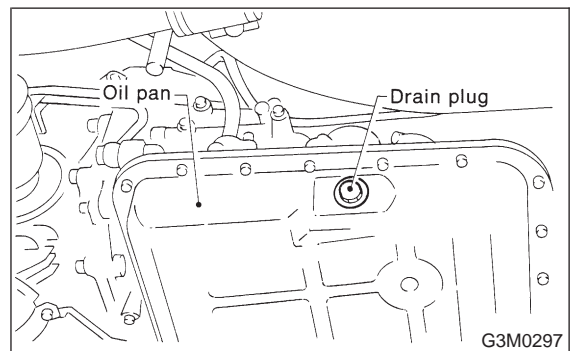

- 3) Remove oil pan, and disconnect connector from shift solenoid 2.
- 4) Measure resistance between shift solenoid 2 connector and transmission ground.

Connector & terminal

(AT2) No. 1 — Transmission ground:

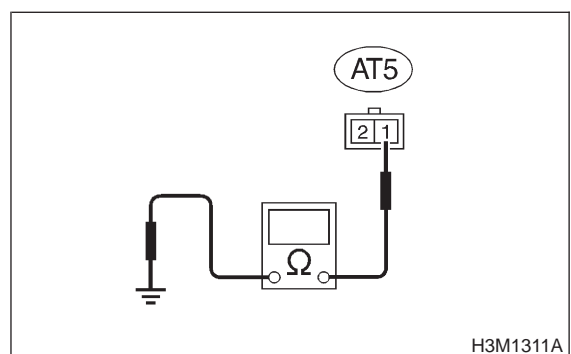

- CHECK** : **Is the resistance between 20 and 32 Ω?**
- YES** : Go to step **8F10**.
- NO** : Replace shift solenoid assembly.

8F10 : CHECK HARNESS CONNECTOR BETWEEN SHIFT SOLENOID 2 AND TRANSMISSION.

Measure resistance of harness between shift solenoid 2 and transmission connector.

Connector & terminal
(AT2) No. 1 — (T4) No. 2:

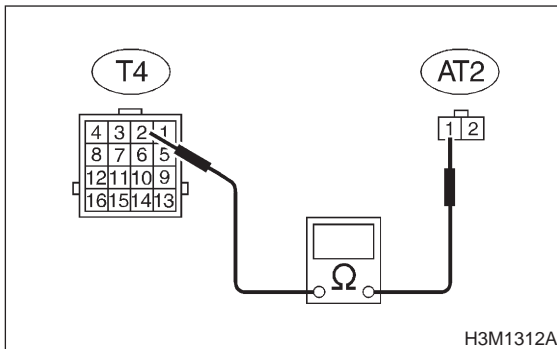

- CHECK** : *Is the resistance less than 1 Ω?*
- YES** : Go to step **8F11**.
- NO** : Repair open circuit in harness between shift solenoid 2 and transmission connector.

8F11 : CHECK HARNESS CONNECTOR BETWEEN SHIFT SOLENOID 2 AND TRANSMISSION.

Measure resistance of harness between shift solenoid 2 connector and transmission ground.

Connector & terminal
(T4) No. 2 — Transmission ground:

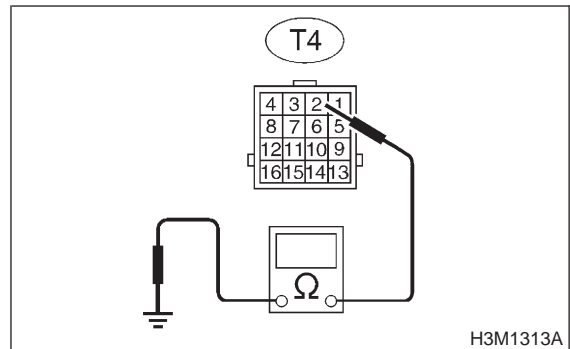

- CHECK** : *Is the resistance more than 1 MΩ?*
- YES** : Even if “AT OIL TEMP” lights up, the circuit has returned to a normal condition at this time. A temporary poor contact of the connector or harness may be the cause. Repair harness or contact in the TCM.
- NO** : Repair short circuit harness between TCM and transmission connector.

3-2 [T8G0] AUTOMATIC TRANSMISSION AND DIFFERENTIAL

8. Diagnostic Chart with Trouble Code

G: TROUBLE CODE 15 — SHIFT SOLENOID 1 —

DIAGNOSIS:

Output signal circuit of shift solenoid 1 is open or shorted.

TROUBLE SYMPTOM:

Does not shift.

WIRING DIAGRAM:

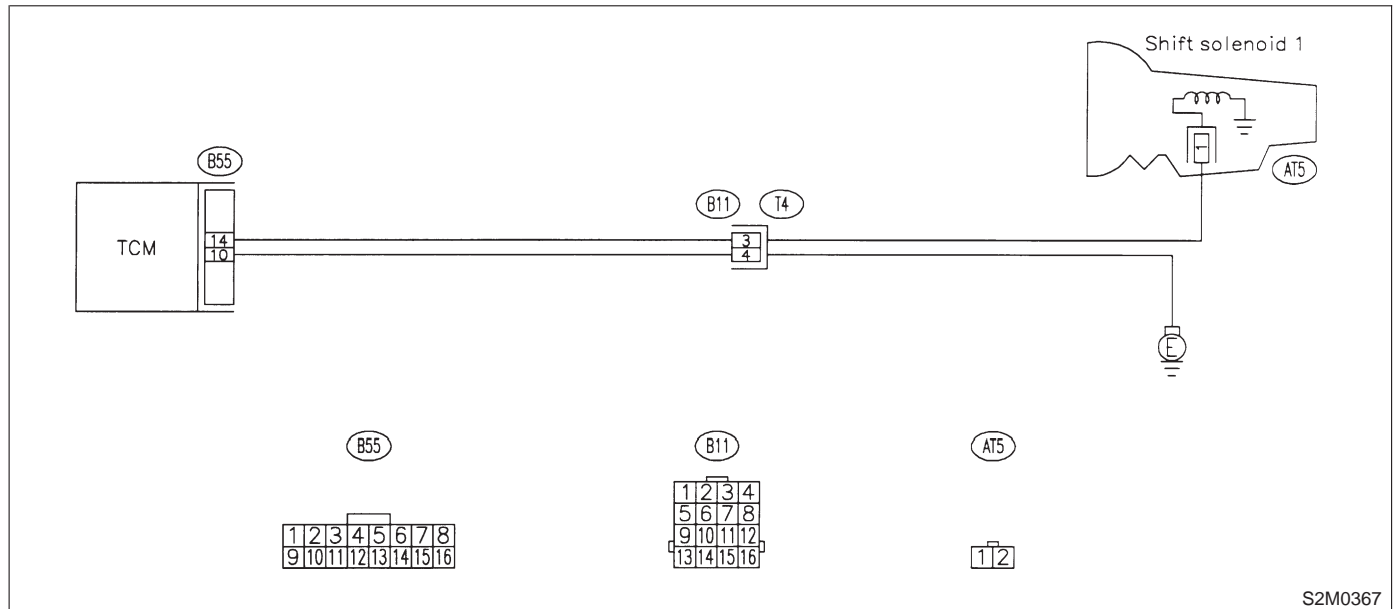

8G1 : CHECK SHIFT SOLENOID 1 GROUND LINE.

- 1) Turn ignition switch to OFF.
- 2) Remove air intake chamber.
- 3) Disconnect connector from transmission.
- 4) Measure resistance between transmission connector and transmission ground.

Connector & terminal

(T4) No. 4 — Chassis ground:

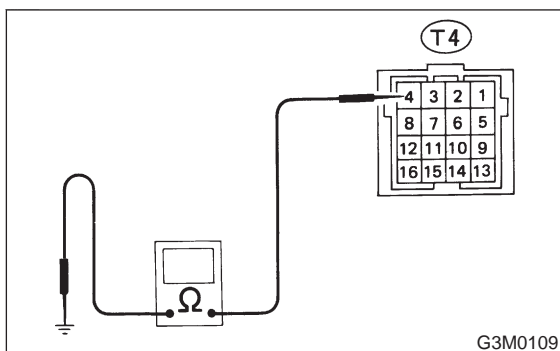

- CHECK** : Is the resistance less than 1 Ω?
- YES** : Go to step 8G2.
- NO** : Repair open circuit in transmission harness.

8G2 : CHECK SHIFT SOLENOID 1.

Measure resistance between transmission connector terminals.

Connector & terminal

(T4) No. 3 — No. 4:

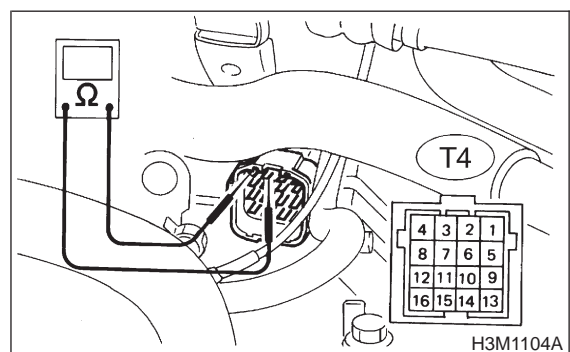

- CHECK** : Is the resistance between 20 and 32 Ω?
- YES** : Go to step 8G3.
- NO** : Go to step 8G9.

8G3 : CHECK HARNESS CONNECTOR BETWEEN TCM AND TRANSMISSION.

- 1) Disconnect connector from TCM.
- 2) Measure resistance of harness between TCM and shift solenoid 1 connector.

Connector & terminal

(B55) No. 14 — (B11) No. 3:

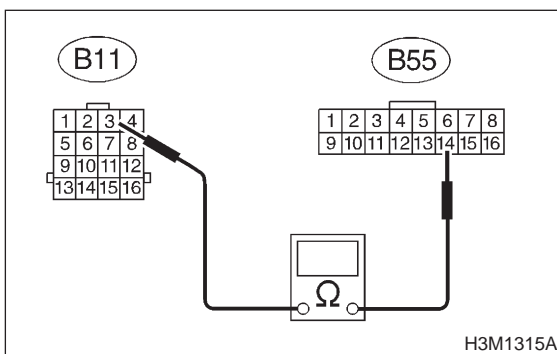

- CHECK** : Is the resistance less than 1 Ω?
- YES** : Go to step **8G4**.
- NO** : Repair open circuit in harness between TCM and transmission connector.

8G4 : CHECK HARNESS CONNECTOR BETWEEN TCM AND TRANSMISSION.

Measure resistance of harness between TCM and shift solenoid 1 connector.

Connector & terminal

(B55) No. 10 — (B11) No. 4:

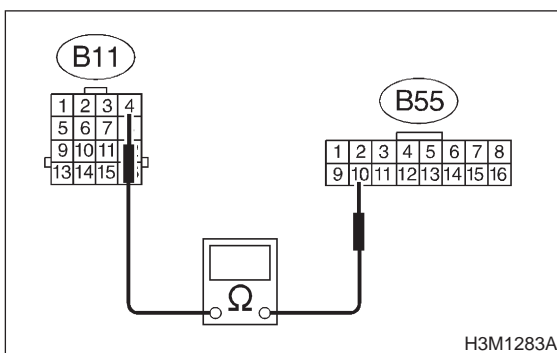

- CHECK** : Is the resistance less than 1 Ω?
- YES** : Go to step **8G5**.
- NO** : Repair open circuit in harness between TCM and transmission connector.

8G5 : CHECK HARNESS CONNECTOR BETWEEN TCM AND TRANSMISSION.

Measure resistance of harness between TCM connector and transmission ground.

Connector & terminal

(B55) No. 14 — Chassis ground:

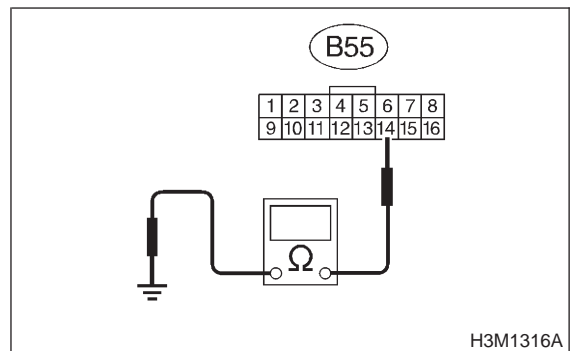

- CHECK** : Is the resistance more than 1 MΩ?
- YES** : Go to step **8G6**.
- NO** : Repair short circuit in harness between TCM and transmission connector.

8G6 : CHECK HARNESS CONNECTOR BETWEEN TCM AND TRANSMISSION.

Measure resistance of harness TCM connector and transmission ground.

Connector & terminal

(B55) No. 10 — Chassis ground:

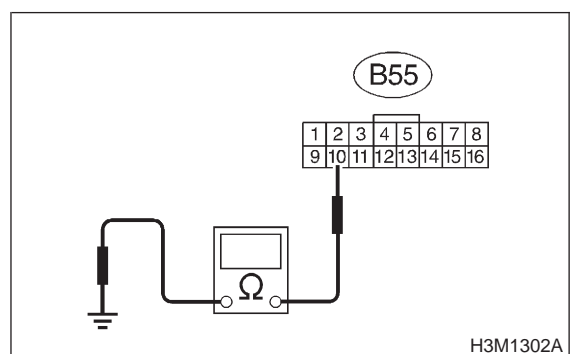

- CHECK** : Is the resistance more than 1 MΩ?
- YES** : Go to step **8G7**.
- NO** : Repair short circuit in harness between TCM and transmission connector.

3-2 [T8G7] AUTOMATIC TRANSMISSION AND DIFFERENTIAL

8. Diagnostic Chart with Trouble Code

8G7 : CHECK OUTPUT SIGNAL EMITTED FROM TCM.

- 1) Connect connectors to TCM and transmission.
- 2) Install air intake chamber.
- 3) Lift-up or raise the vehicle and support with safety stand.

CAUTION:

On AWD models, raise all wheels off ground.

- 4) Start the engine and warm-up the transmission until ATF temperature is above 80°C (176°F).

NOTE:

If ambient temperature is below 0°C (32°F), drive the vehicle until the ATF reaches its operating temperature.

- 5) Move selector lever to "D", and slowly increase vehicle speed to 50 km/h (31 m/h).

NOTE:

The speed difference between front and rear wheels may light the ABS warning light, but this indicates no malfunction. When AT control diagnosis is finished, perform the ABS memory clearance procedure of on-board diagnostics system. <Ref. to 4-4 [T6D2].>

- 6) Measure voltage between TCM connector terminals.

Connector & terminal

(B55) No. 14 (+) — No. 10 (-):

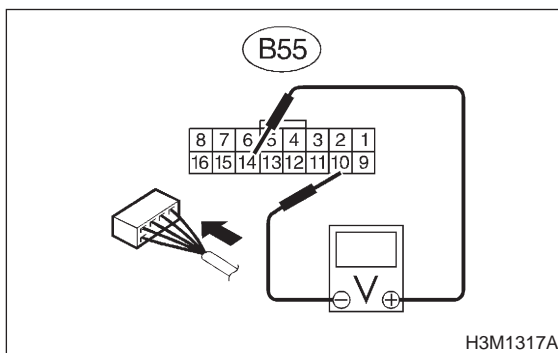

CHECK : **Is the voltage 1 V → 9 V?**

YES : Even if "AT OIL TEMP" lights up, the circuit has returned to a normal condition at this time. A temporary poor contact of the connector or harness may be the cause. Repair harness or connector in the TCM.

NO : Go to step **8G8**.

8G8 : CHECK POOR CONTACT.

CHECK : **Is there poor contact in shift solenoid 1 circuit?**

YES : Repair poor contact.

NO : Replace TCM.

8G9 : CHECK SHIFT SOLENOID 1 (IN TRANSMISSION).

- 1) Remove transmission connector from bracket.
- 2) Lift-up or raise the vehicle and support with safety stand.

CAUTION:

On AWD models, raise all wheels off ground.

- 3) Drain automatic transmission fluid.

CAUTION:

Do not drain the automatic transmission fluid until it cools down.

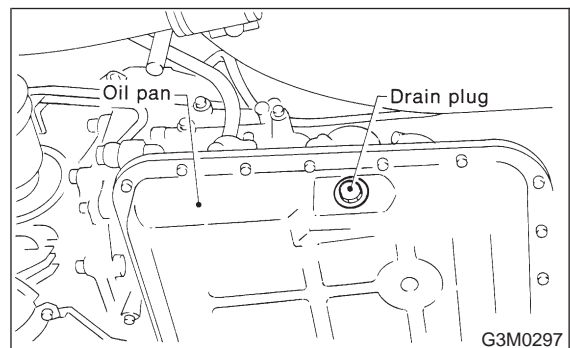

- 4) Remove oil pan, and disconnect connector from shift solenoid 1.

- 5) Measure resistance between shift solenoid 1 connector and transmission ground.

Connector & terminal

(AT5) No. 1 — Transmission ground:

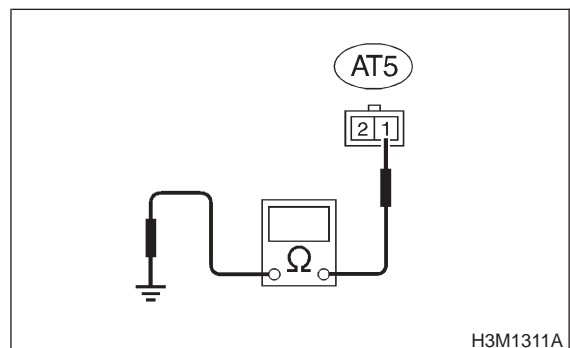

CHECK : **Is the resistance between 20 and 32 Ω?**

YES : Go to step **8G10**.

NO : Replace shift solenoid assembly.

8G10 : CHECK HARNESS CONNECTOR BETWEEN SHIFT SOLENOID 1 AND TRANSMISSION.

Measure resistance of harness between shift solenoid 1 and transmission connector.

Connector & terminal
(AT5) No. 1 — (T4) No. 3:

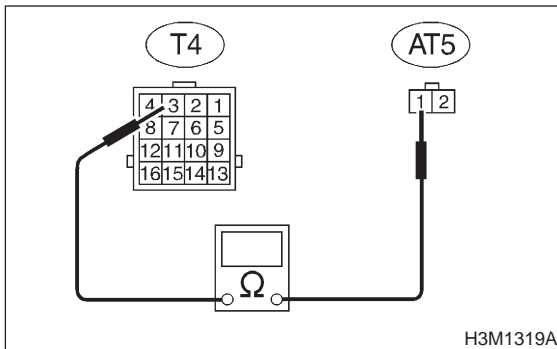

- CHECK** : **Is the resistance less than 1 Ω?**
- YES** : Go to step **8G11**.
- NO** : Repair open circuit in harness between TCM and transmission connector.

8G11 : CHECK HARNESS CONNECTOR BETWEEN SHIFT SOLENOID 1 AND TRANSMISSION.

Measure resistance of harness between shift solenoid 1 connector and transmission ground.

Connector & terminal
(T4) No. 3 — Transmission ground:

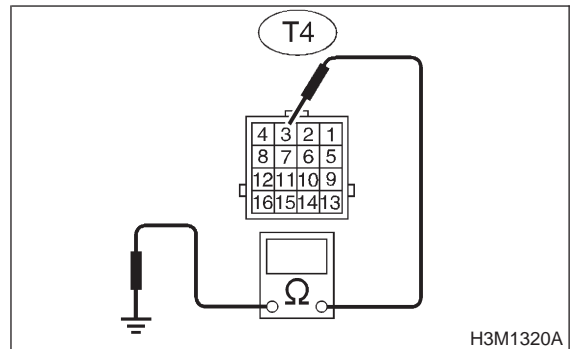

- CHECK** : **Is the resistance more than 1 MΩ?**
- YES** : Even if “AT OIL TEMP” lights up, the circuit has returned to a normal condition at this time. A temporary poor contact of the connector or harness may be the cause. Repair harness or connector in shift solenoid 1 and transmission.
- NO** : Repair short circuit harness between TCM and transmission connector.

3-2 [T8H0] AUTOMATIC TRANSMISSION AND DIFFERENTIAL

8. Diagnostic Chart with Trouble Code

H: TROUBLE CODE 21 — ATF TEMPERATURE SENSOR —

DIAGNOSIS:

Input signal circuit of TCM to ATF temperature sensor is open or shorted.

TROUBLE SYMPTOM:

Excessive shift shock.

WIRING DIAGRAM:

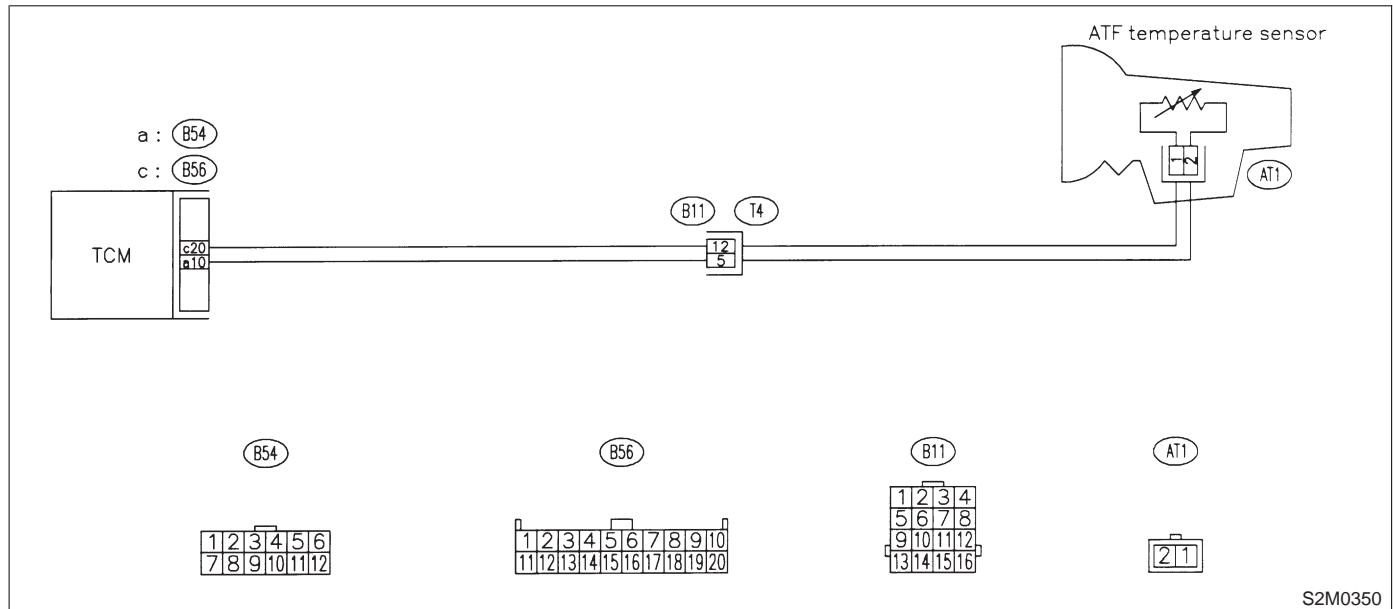

8H1 : CHECK HARNESS CONNECTOR BETWEEN TCM AND ATF TEMPERATURE SENSOR.

- 1) Turn ignition switch to OFF.
- 2) Remove air intake chamber.
- 3) Disconnect connector from transmission and TCM.
- 4) Measure resistance of harness between TCM and transmission connector.

Connector & terminal

(B54) No. 10 — (B11) No. 5:

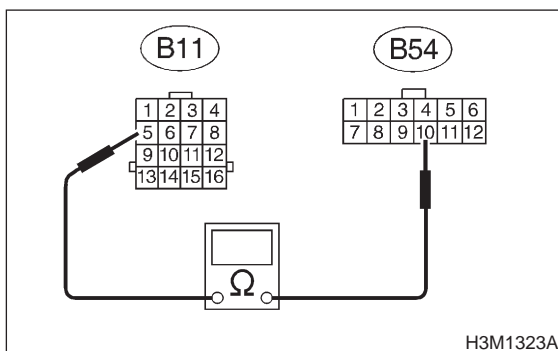

- CHECK** : Is the resistance less than 1 Ω?
- YES** : Go to step 8H2.
- NO** : Repair open circuit in harness between TCM and transmission connector.

8H2 : CHECK HARNESS CONNECTOR BETWEEN TCM AND ATF TEMPERATURE SENSOR.

Measure resistance of harness between TCM and transmission connector.

Connector & terminal

(B56) No. 20 — (B11) No. 12:

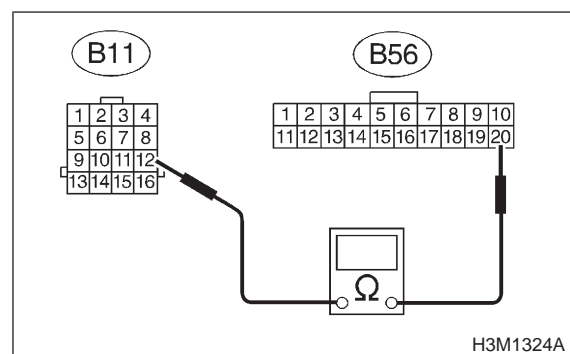

- CHECK** : Is the resistance less than 1 Ω?
- YES** : Go to step 8H3.
- NO** : Repair open circuit in harness between TCM and transmission connector.

8H3 : CHECK HARNESS CONNECTOR BETWEEN TCM AND ATF TEMPERATURE SENSOR.

Measure resistance of harness between TCM connector and transmission ground.

Connector & terminal

(B54) No. 10 — Chassis ground:

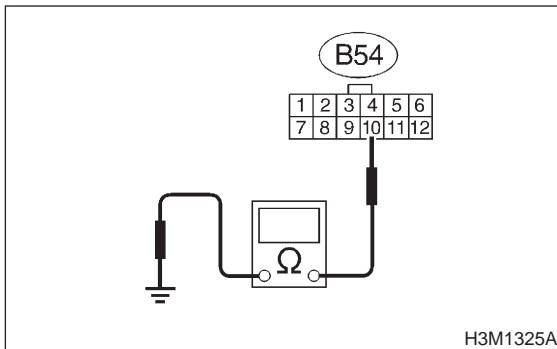

- CHECK** : *Is the resistance more than 1 MΩ?*
- YES** : Go to step **8H4**.
- NO** : Repair short circuit in harness between TCM and transmission connector.

8H4 : CHECK HARNESS CONNECTOR BETWEEN TCM AND ATF TEMPERATURE SENSOR.

Measure resistance of harness between TCM connector and transmission ground.

Connector & terminal

(B56) No. 20 — Chassis ground:

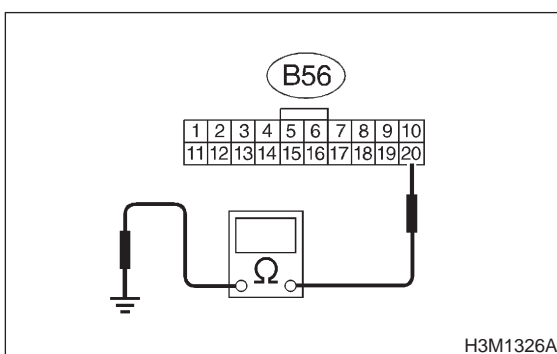

- CHECK** : *Is the resistance more than 1 MΩ?*
- YES** : Go to step **8H5**.
- NO** : Repair short circuit in harness between TCM and transmission connector.

8H5 : CHECK ATF TEMPERATURE SENSOR.

- 1) Turn ignition switch to OFF.
- 2) Connect connectors to transmission and TCM.
- 3) Turn ignition switch to ON and start engine.
- 4) Warm-up the transmission until ATF temperature reaches to 80°C (176°F).

NOTE:

If ambient temperature is below 0°C (32°F), drive the vehicle until the ATF reaches its operating temperature.

- 5) Measure resistance between transmission connector terminals.

Connector & terminal

(B11) No. 12 — No. 5:

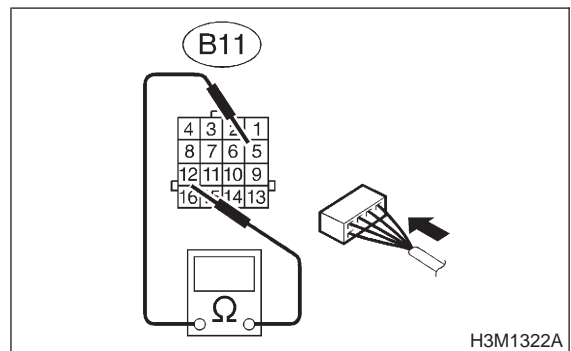

- CHECK** : *Is the resistance between 272 and 374 Ω?*
- YES** : Go to step **8H6**.
- NO** : Go to step **8H13**.

3-2 [T8H6] AUTOMATIC TRANSMISSION AND DIFFERENTIAL

8. Diagnostic Chart with Trouble Code

8H6 : CHECK ATF TEMPERATURE SENSOR.

- 1) Turn ignition switch to ON (engine OFF).
- 2) Measure resistance between transmission connector terminals.

Connector & terminal
(B11) No. 12 — No. 5:

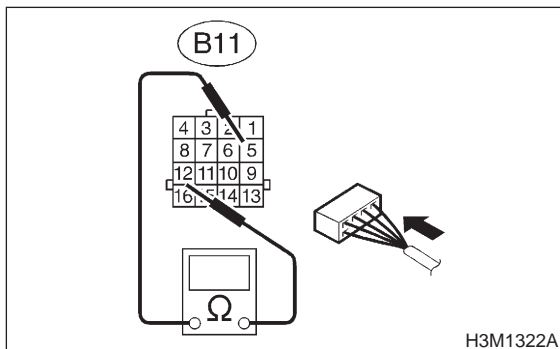

CHECK : Does the resistance value increase while the ATF temperature decreases?

YES : Go to step 8H7.

NO : Go to step 8H13.

8H7 : PREPARE SUBARU SELECT MONITOR.

CHECK : Do you have a Subaru Select Monitor?

YES : Go to step 8H10.

NO : Go to step 8H8.

8H8 : CHECK INPUT SIGNAL FOR TCM.

- 1) Warm-up the transmission until ATF temperature is about 80°C (176°F).

NOTE:

If ambient temperature is below 0°C (32°F), drive the vehicle until the ATF reaches its operating temperature.

- 2) Measure voltage between TCM connector terminal.

Connector & terminal
(B54) No. 10 (+) — (B56) No. 20 (-):

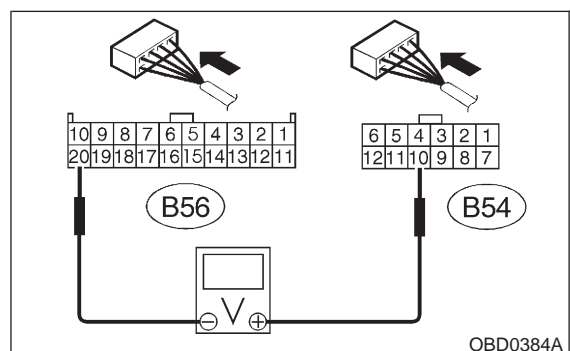

CHECK : Is the voltage between 2.9 and 4.0 V?

YES : Go to step 8H9.

NO : Go to step 8H12.

8H9 : CHECK INPUT SIGNAL FOR TCM.

- 1) Turn ignition switch to ON (engine OFF).
- 2) Measure voltage between TCM connector terminal.

Connector & terminal

(B54) No. 10 (+) — (B56) No. 20 (-):

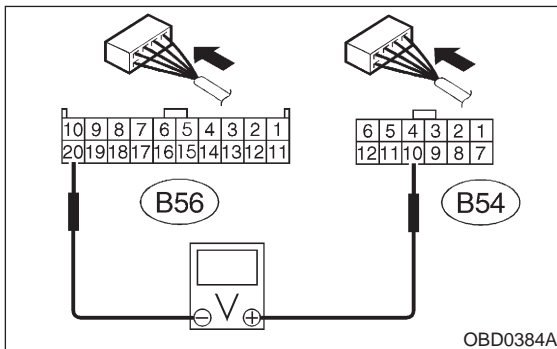

- CHECK** : **Is the voltage between 1.0 and 1.4 V?**
- YES** : Even if “AT OIL TEMP” lights up, the circuit has returned to a normal condition at this time. A temporary poor contact of the connector or harness may be the cause. Repair harness or contact in the TCM.
- NO** : Go to step **8H12**.

8H10 : CHECK INPUT SIGNAL FOR TCM USING SUBARU SELECT MONITOR.

- 1) Turn ignition switch to OFF.
- 2) Connect connectors to TCM and transmission.
- 3) Connect Subaru Select Monitor to data link connector.

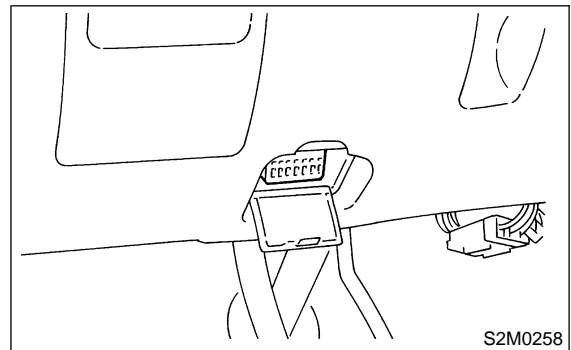

- 4) Start the engine, and turn Subaru Select Monitor switch to ON.
- 5) Warm-up the transmission until ATF temperature is above 80°C (176°F).

NOTE:

If ambient temperature is below 0°C (32°F), drive the vehicle until the ATF reaches its operating temperature.

- 6) Read data of ATF temperature using Subaru Select Monitor.

● ATF temperature is indicated in “°F” or “°C”.

- CHECK** : **Is the ATF temperature between 70 and 110°C (158 and 230°F).**
- YES** : Go to step **8H11**.
- NO** : Go to step **8H12**.

8H11 : CHECK INPUT SIGNAL FOR TCM USING SUBARU SELECT MONITOR.

Turn ignition switch to ON (engine OFF).

- CHECK** : **Does the ATF temperature gradually decrease?**
- YES** : Even if “AT OIL TEMP” light up, the circuit has returned to a normal condition at this time. Temporary poor contact of the connector or harness may be the case. Repair harness or contact in the ATF temperature sensor and transmission connector.
- NO** : Go to step **8H12**.

3-2 [T8H12] AUTOMATIC TRANSMISSION AND DIFFERENTIAL

8. Diagnostic Chart with Trouble Code

8H12 : CHECK POOR CONTACT.

CHECK : *Is there poor contact in ATF temperature sensor circuit?*

YES : Repair poor contact.

NO : Replace TCM.

8H13 : CHECK ATF TEMPERATURE SENSOR (IN TRANSMISSION).

- 1) Turn ignition switch to OFF.
- 2) Disconnect connector from transmission.
- 3) Remove transmission connector from bracket.
- 4) Lift-up the vehicle and place safety stand.

CAUTION:

On AWD models, raise all wheels off ground.

- 5) Drain automatic transmission fluid.

CAUTION:

Do not drain the automatic transmission fluid until it cools down.

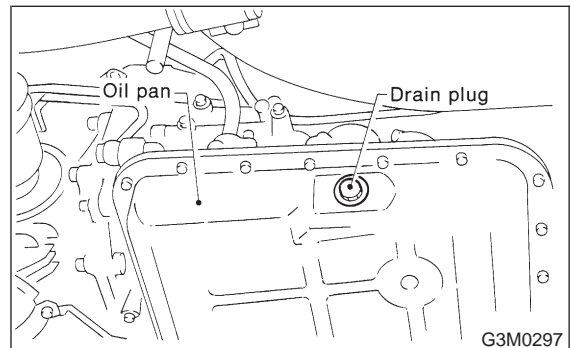

- 6) Remove oil pan, and disconnect connector from ATF temperature sensor connector.
- 7) Measure resistance between ATF temperature sensor connector and transmission ground.

Connector & terminal

(AT1) No. 2 — Transmission ground:

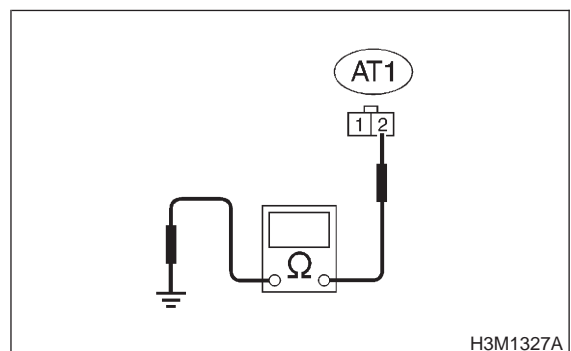

CHECK : *Is the resistance between 1.5 and 4.5 Ω?*

YES : Go to step **8H14**.

NO : Replace ATF temperature sensor.

8H14 : CHECK HARNESS CONNECTOR BETWEEN TRANSMISSION AND ATF TEMPERATURE SENSOR.

- 1) Disconnect connector from transmission.
- 2) Measure resistance of harness between ATF temperature sensor and transmission connector.

Connector & terminal

(T4) No. 12 — (AT1) No. 1:

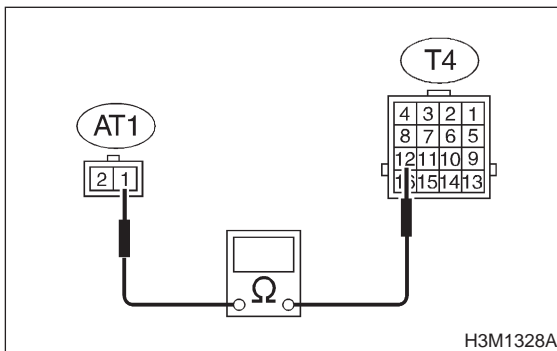

- CHECK** : **Is the resistance less than 1 Ω?**
- YES** : Go to step **8H15**.
- NO** : Repair open circuit in harness between ATF temperature sensor and transmission connector.

8H15 : CHECK HARNESS CONNECTOR BETWEEN TRANSMISSION AND ATF TEMPERATURE SENSOR.

Measure resistance of harness between ATF temperature sensor and transmission connector.

Connector & terminal

(T4) No. 5 — (AT1) No. 2:

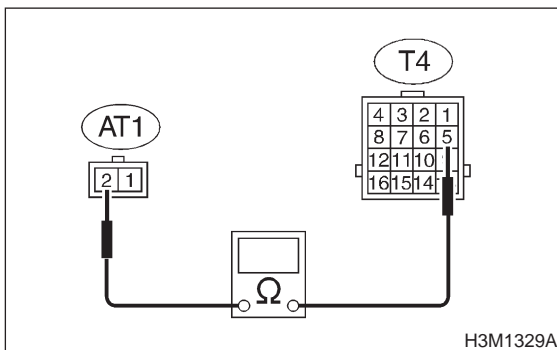

- CHECK** : **Is the resistance less than 1 Ω?**
- YES** : Go to step **8H16**.
- NO** : Repair open circuit in harness between ATF temperature sensor and transmission connector.

8H16 : CHECK HARNESS CONNECTOR BETWEEN TRANSMISSION AND ATF TEMPERATURE SENSOR.

Measure resistance of harness between transmission connector and transmission ground.

Connector & terminal

(T4) No. 5 — Transmission ground:

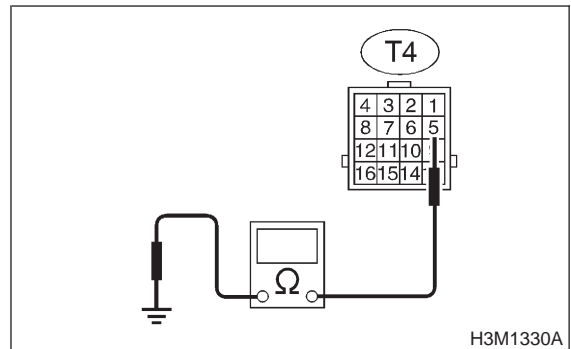

- CHECK** : **Is the resistance more than 1 MΩ?**
- YES** : Go to step **8H17**.
- NO** : Repair short circuit in harness between ATF temperature sensor and transmission connector.

3-2 [T8H17] AUTOMATIC TRANSMISSION AND DIFFERENTIAL

8. Diagnostic Chart with Trouble Code

8H17 : CHECK HARNESS CONNECTOR BETWEEN TRANSMISSION AND ATF TEMPERATURE SENSOR.

Measure resistance of harness between transmission connector and transmission ground.

Connector & terminal

(T4) No. 12 — Transmission ground:

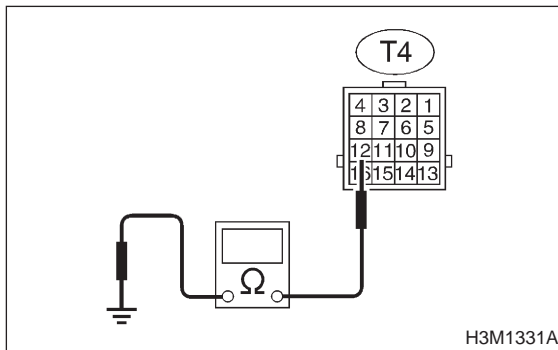

- CHECK** : **Is the resistance more than 1 MΩ?**
- YES** : Even if "AT OIL TEMP" lights up, the circuit has returned to a normal condition at this time. A temporary poor contact of the connector or harness may be the cause. Repair harness or contact in the ATF temperature sensor and transmission connector.
- NO** : Repair short circuit in harness between ATF temperature sensor and transmission connector.

MEMO:

3-2 [T810] AUTOMATIC TRANSMISSION AND DIFFERENTIAL

8. Diagnostic Chart with Trouble Code

I: TROUBLE CODE 22 — MASS AIR FLOW SIGNAL —

DIAGNOSIS:

Input signal circuit of TCM from ECM is open or shorted.

TROUBLE SYMPTOM:

Excessive shift shock.

WIRING DIAGRAM:

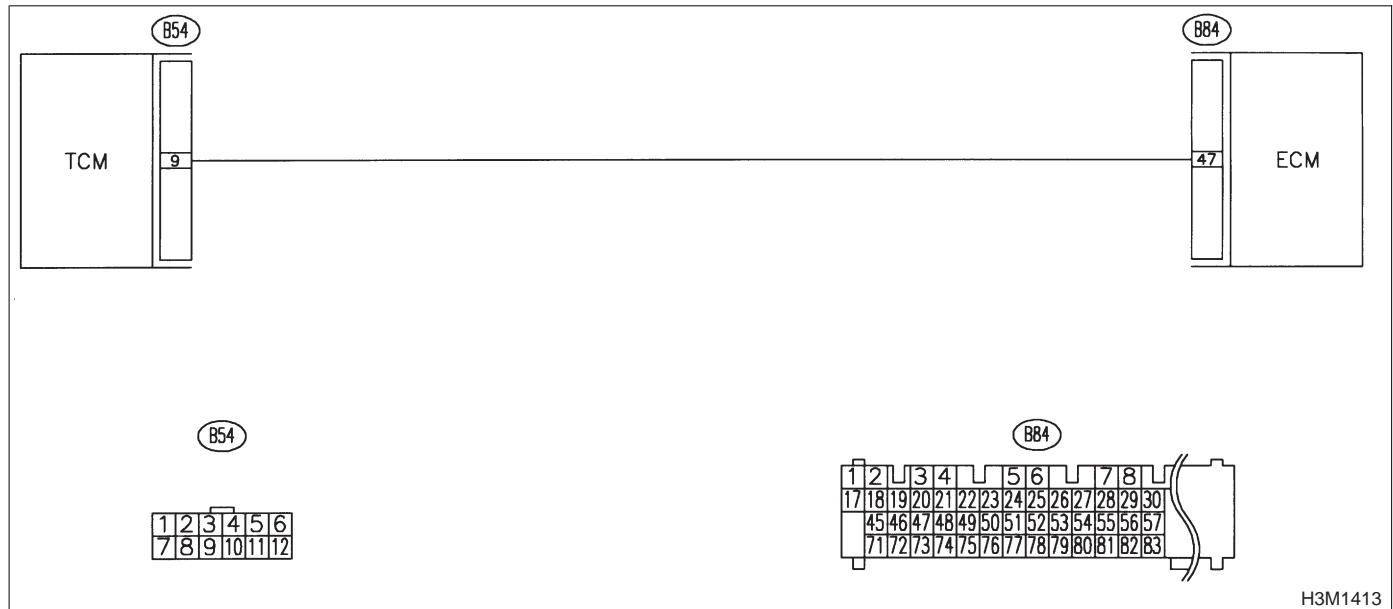

811 : CHECK HARNESS CONNECTOR BETWEEN TCM AND ECM.

- 1) Turn ignition switch to OFF.
- 2) Disconnect connectors from TCM and ECM.
- 3) Measure resistance of harness between TCM and ECM connector.

Connector & terminal

(B54) No. 9 — (B84) No. 47:

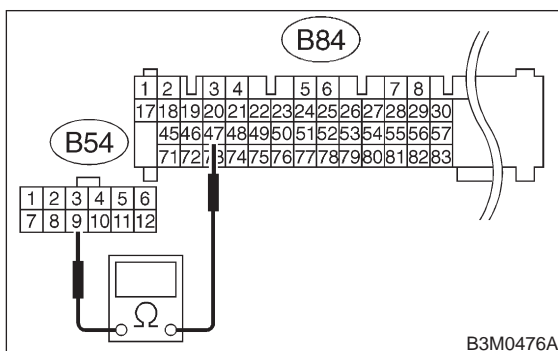

- CHECK** : Is the resistance less than 1 Ω?
- YES** : Go to step 812.
- NO** : Repair open circuit in harness between TCM and ECM connector.

812 : CHECK HARNESS CONNECTOR BETWEEN TCM AND ECM.

Measure resistance of harness between TCM connector and chassis ground.

Connector & terminal

(B54) No. 9 — Chassis ground:

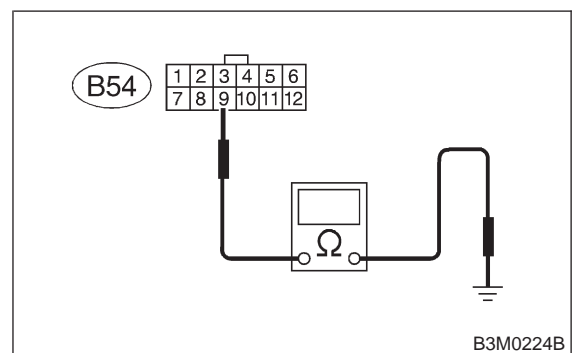

- CHECK** : Is the resistance more than 1 MΩ?
- YES** : Go to step 813.
- NO** : Repair short circuit in harness between TCM and ECM connector.

813 : PREPARE SUBARU SELECT MONITOR.

- CHECK** : *Do you have a Subaru Select Monitor?*
- YES** : Go to step **815**.
- NO** : Go to step **814**.

814 : CHECK INPUT SIGNAL FOR TCM.

- 1) Connect connectors to TCM and ECM.
- 2) Start the engine, and warm-up the transmission until ATF temperature is above 80°C (176°F).

NOTE:

If ambient temperature is below 0°C (32°F), drive the vehicle until the ATF reaches its operating temperature.

- 3) Engine idling.
- 4) Measure voltage between TCM connectors.

Connector & terminal

(B54) No. 9 (+) — No. 7 (-):

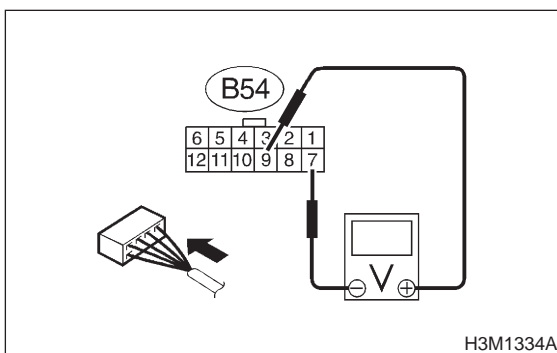

- CHECK** : *Is the voltage between 0.5 and 1.2 V?*
- YES** : Even if "AT OIL TEMP" lights up, the circuit has returned to a normal condition at this time. A temporary poor contact of the connector or harness may be the cause. Repair harness or connector in the TCM and ECM.
- NO** : Go to step **816**.

815 : CHECK INPUT SIGNAL FOR TCM USING SUBARU SELECT MONITOR.

- 1) Connect connectors to TCM and ECM.
- 2) Turn ignition switch to OFF.
- 3) Connect Subaru Select Monitor to data link connector.

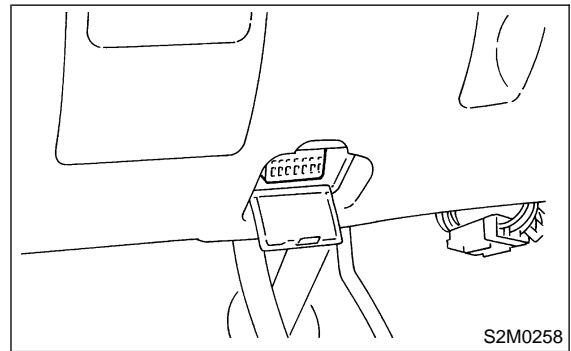

- 4) Start the engine, and turn Subaru Select monitor switch to ON.
 - 5) Warm-up the engine until engine coolant temperature is above 80°C (176°F).
 - 6) Engine idling.
 - 7) Read data of mass air flow signal using Subaru Select Monitor.
- Display shows mass air flow signal value sent from ECM.

- CHECK** : *Is the value between 0.5 and 1.2 V?*
- YES** : Even if "AT OIL TEMP" lights up, the circuit has returned to a normal condition at this time. A temporary poor contact of the connector or harness may be the cause. Repair harness or connector in the TCM and ECM.
- NO** : Go to step **816**.

816 : CHECK POOR CONTACT.

- CHECK** : *Is there poor contact in mass air flow signal circuit?*
- YES** : Repair poor contact.
- NO** : Replace TCM.

3-2 [T8J0] AUTOMATIC TRANSMISSION AND DIFFERENTIAL

8. Diagnostic Chart with Trouble Code

J: TROUBLE CODE 23 — ENGINE SPEED SIGNAL —

DIAGNOSIS:

Engine speed input signal circuit is open or shorted.

TROUBLE SYMPTOM:

- No lock-up (after engine warm-up).
- AT OIL TEMP indicator remains on when vehicle speed is "0".

WIRING DIAGRAM:

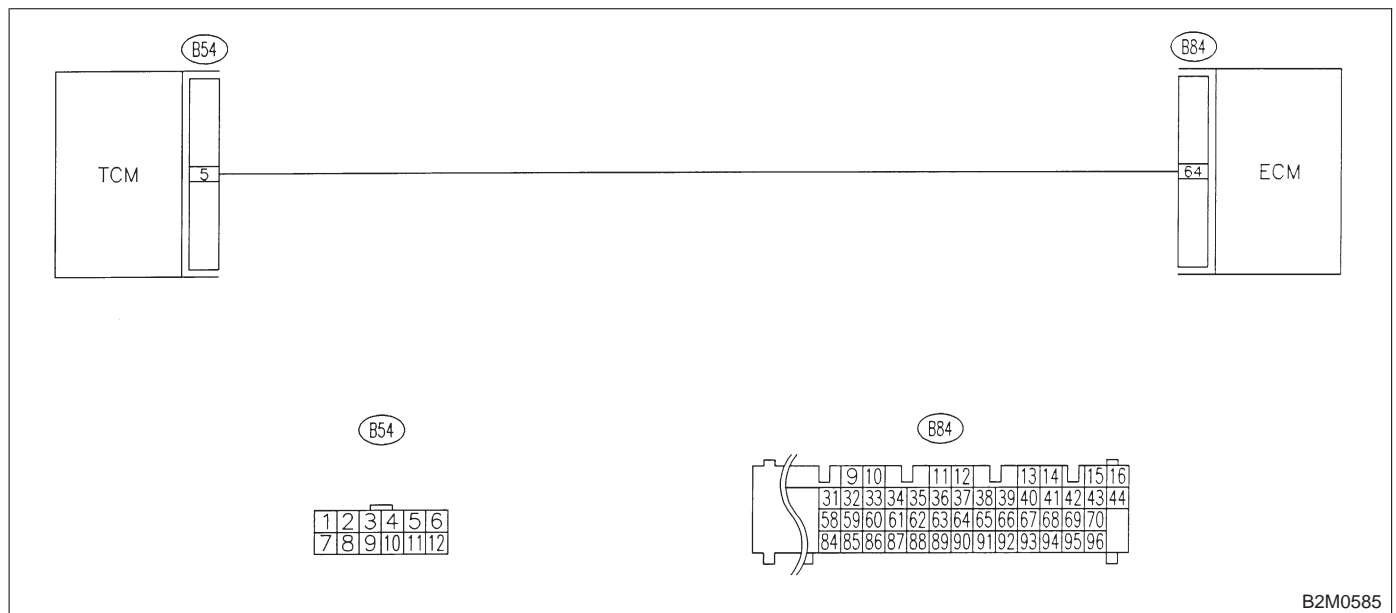

8J1 : CHECK HARNESS CONNECTOR BETWEEN TCM AND ECM.

- 1) Turn ignition switch to OFF.
- 2) Disconnect connectors from TCM and ECM.
- 3) Measure resistance of harness between TCM and ECM connector.

Connector & terminal

(B54) No. 5 — (B84) No. 64:

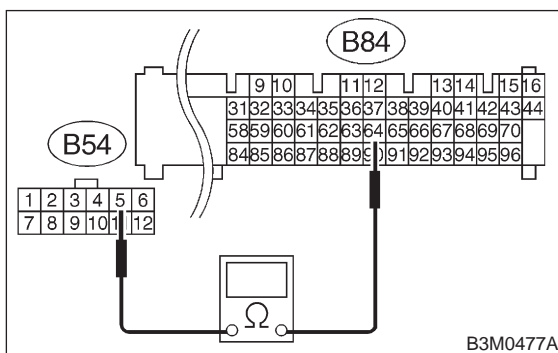

- CHECK** : Is the resistance less than 1 Ω?
- YES** : Go to step 8J2.
- NO** : Repair open circuit in harness between TCM and ECM connector.

8J2 : CHECK HARNESS CONNECTOR BETWEEN TCM AND ECM.

Measure resistance of harness between TCM connector and chassis ground.

Connector & terminal

(B54) No. 5 — Chassis ground:

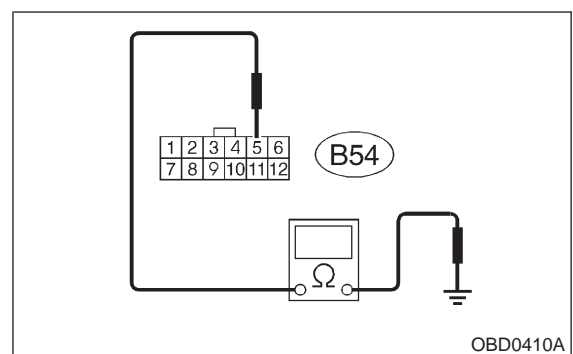

- CHECK** : Is the resistance more than 1 MΩ?
- YES** : Go to step 8J3.
- NO** : Repair short circuit in harness between TCM and ECM connector.

8J3 : PREPARE SUBARU SELECT MONITOR.

- CHECK** : *Do you have a Subaru Select Monitor?*
- YES** : Go to step **8J5**.
- NO** : Go to step **8J4**.

8J4 : CHECK INPUT SIGNAL FOR TCM.

- 1) Connect connectors to TCM and ECM.
- 2) Turn ignition switch to ON (engine OFF).
- 3) Measure voltage between TCM connectors.

Connector & terminal

(B54) No. 5 (+) — (B55) No. 10 (-):

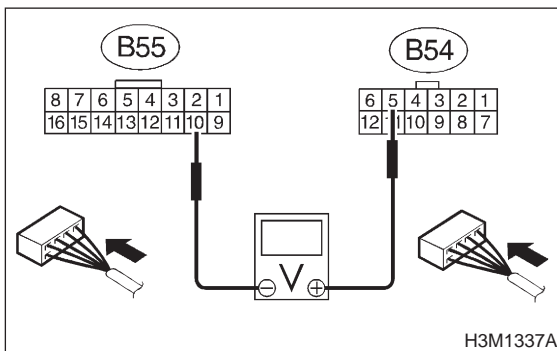

- CHECK** : *Is the voltage more than 10.5 V?*
- YES** : Even if "AT OIL TEMP" lights up, the circuit has returned to a normal condition at this time. A temporary poor contact of the connector or harness may be the cause. Repair harness or connector in the TCM and ECM.
- NO** : Go to step **8J6**.

8J5 : CHECK INPUT SIGNAL FOR TCM USING SUBARU SELECT MONITOR.

- 1) Connect connectors to TCM and ECM.
- 2) Connect Subaru Select Monitor to data link connector.

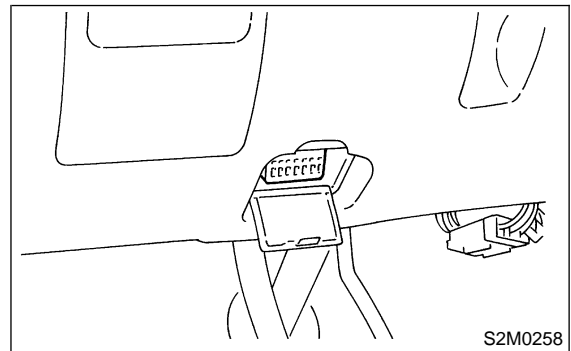

- 3) Start the engine, and turn Subaru Select Monitor switch to ON.
- 4) Warm-up the engine until engine coolant temperature is above 80°C (176°F).
- 5) Engine idling.
- 6) Read data of engine speed using Subaru Select Monitor.
 - Display shows engine speed signal value sent from ECM.

- CHECK** : *Is the revolution value the same as the tachometer reading shown on the combination meter?*
- YES** : Even if "AT OIL TEMP" lights up, the circuit has returned to a normal condition at this time. A temporary poor contact of the connector or harness may be the cause. Repair harness or connector in the TCM and ECM.
- NO** : Go to step **8J6**.

8J6 : CHECK POOR CONTACT.

- CHECK** : *Is there poor contact in engine speed signal circuit?*
- YES** : Repair poor contact.
- NO** : Go to step **8J7**.

8J7 : CONFIRM TROUBLE CODE 23.

- CHECK** : *Replace ECM with a new one. Does the trouble code appear again, after the memory has been cleared?*
- YES** : Replace TCM.
- NO** : Replace ECM.

3-2 [T8K0] AUTOMATIC TRANSMISSION AND DIFFERENTIAL

8. Diagnostic Chart with Trouble Code

K: TROUBLE CODE 24 — DUTY SOLENOID C —

DIAGNOSIS:

Output signal circuit of duty solenoid C is open or shorted.

TROUBLE SYMPTOM:

Excessive “braking” in tight corners.

WIRING DIAGRAM:

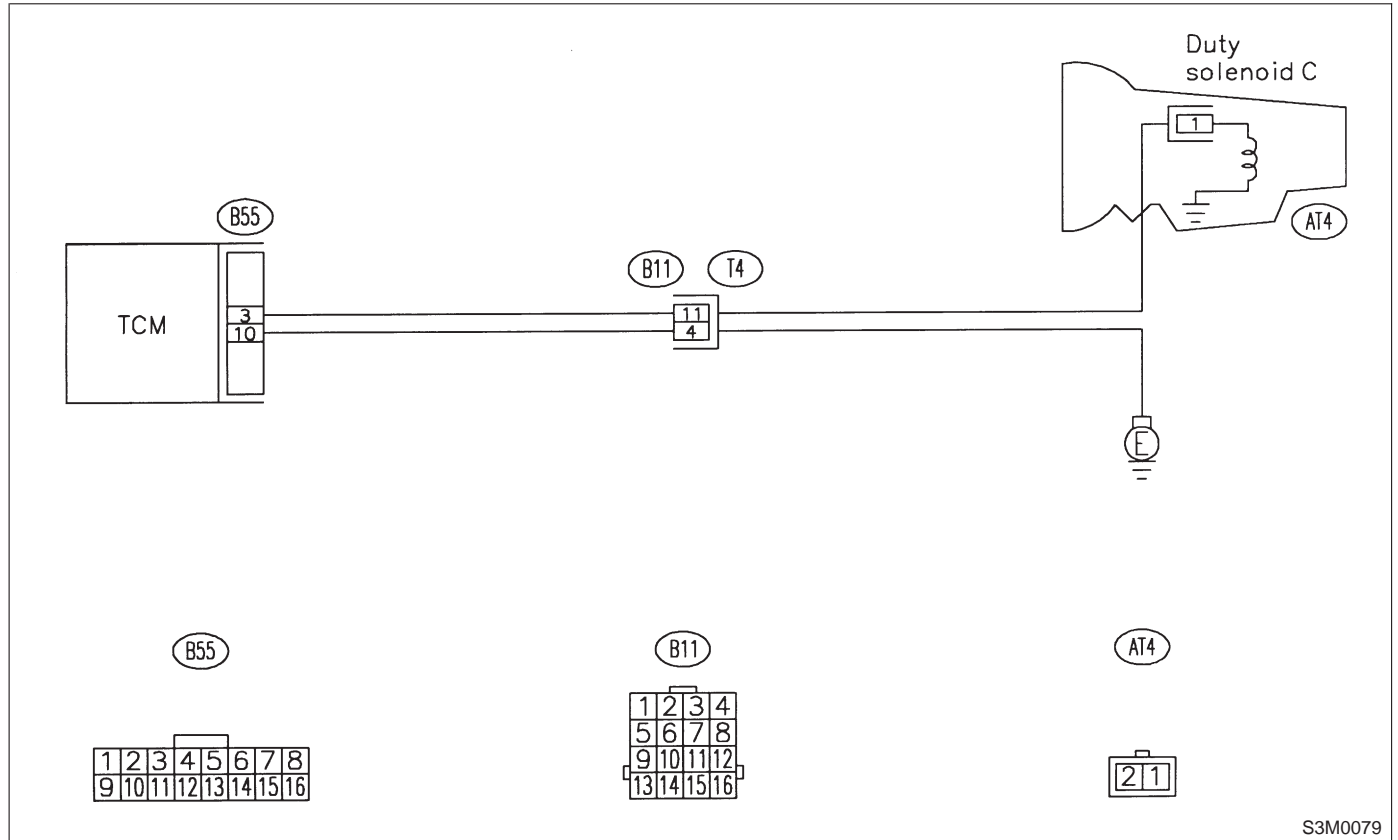

S3M0079

8K1 : CHECK DUTY SOLENOID C GROUND LINE.

- 1) Turn ignition switch to OFF.
- 2) Remove air intake chamber.
- 3) Disconnect connector from transmission.
- 4) Measure resistance between transmission connector and transmission ground.

Connector & terminal

(T4) No. 4 — Chassis ground:

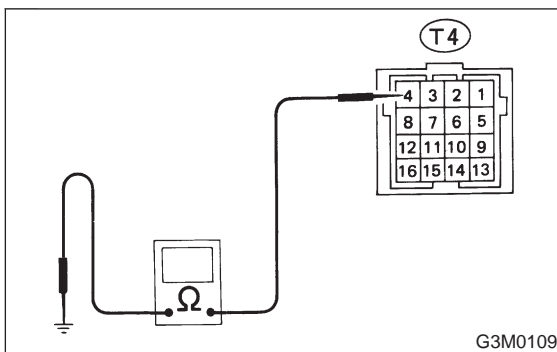

- CHECK** : Is the resistance less than 1 Ω?
- YES** : Go to step 8K2.
- NO** : Repair open circuit in transmission harness.

8K2 : CHECK DUTY SOLENOID C.

Measure resistance between transmission connector and transmission terminals.

Connector & terminal

(T4) No. 11 — No. 4:

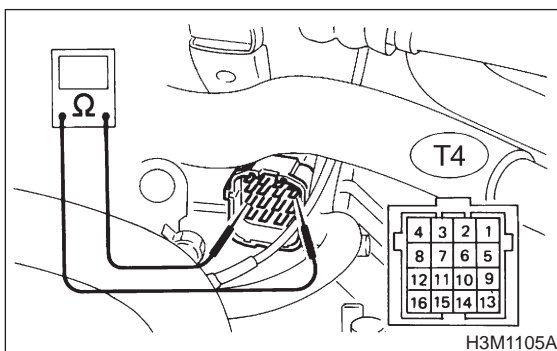

- CHECK** : Is the resistance between 9 and 17 Ω?
- YES** : Go to step 8K3.
- NO** : Go to step 8K13.

8K3 : CHECK HARNESS CONNECTOR BETWEEN TCM AND TRANSMISSION.

- 1) Disconnect connector from TCM.
- 2) Measure resistance of harness between TCM and transmission connector.

Connector & terminal

(B55) No. 3 — (B11) No. 11:

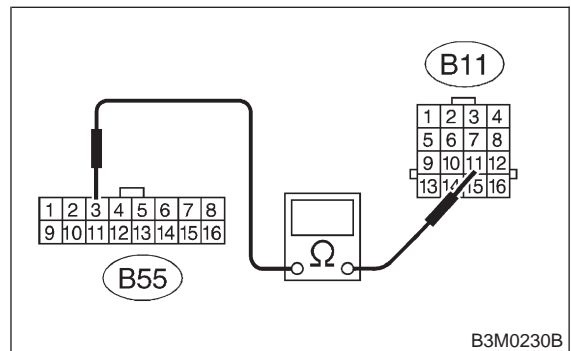

- CHECK** : Is the resistance less than 1 Ω?
- YES** : Go to step 8K4.
- NO** : Repair open circuit in harness between TCM and transmission connector.

8K4 : CHECK HARNESS CONNECTOR BETWEEN TCM AND TRANSMISSION.

Measure resistance harness connector between TCM and transmission connector.

Connector & terminal

(B55) No. 10 — (B11) No. 4:

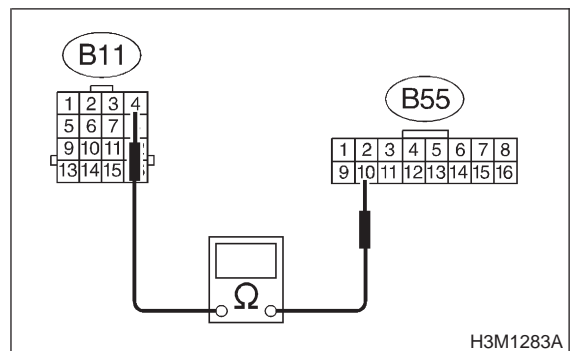

- CHECK** : Is the resistance less than 1 Ω?
- YES** : Go to step 8K5.
- NO** : Repair open circuit in harness between TCM and transmission connector.

3-2 [T8K5] AUTOMATIC TRANSMISSION AND DIFFERENTIAL

8. Diagnostic Chart with Trouble Code

8K5 : CHECK HARNESS CONNECTOR BETWEEN TCM AND TRANSMISSION.

Measure resistance harness connector between TCM and chassis ground.

Connector & terminal
(B55) No. 3 — Chassis ground:

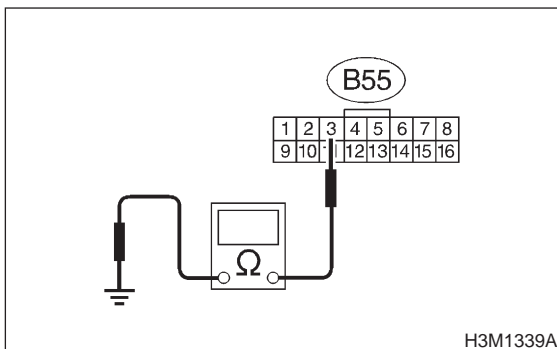

- CHECK** : Is the resistance more than 1 MΩ?
YES : Go to step 8K6.
NO : Repair short circuit in harness between TCM and transmission connector.

8K6 : CHECK HARNESS CONNECTOR BETWEEN TCM AND TRANSMISSION.

Measure resistance harness connector between TCM and chassis ground.

Connector & terminal
(B55) No. 10 — Chassis ground:

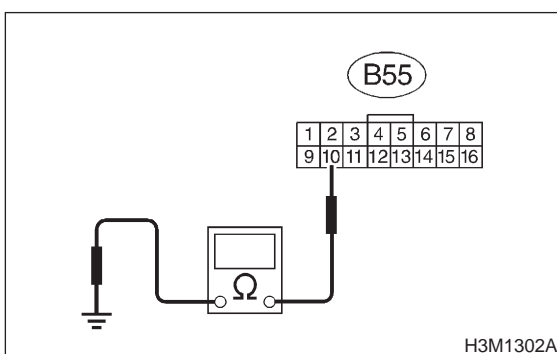

- CHECK** : Is the resistance more than 1 MΩ?
YES : Go to step 8K7.
NO : Repair short circuit in harness between TCM and transmission connector.

8K7 : PREPARE SUBARU SELECT MONITOR.

- CHECK** : Do you have a Subaru Select Monitor?
YES : Go to step 8K10.
NO : Go to step 8K8.

8K8 : CHECK OUTPUT SIGNAL EMITTED FROM TCM.

- 1) Connect connectors to TCM and transmission.
- 2) Install air intake chamber.
- 3) Turn ignition switch to ON (engine OFF).
- 4) Throttle is fully closed.
- 5) Measure voltage between TCM connector terminals.

Connector & terminal
(B55) No. 3 (+) — No. 10 (-):

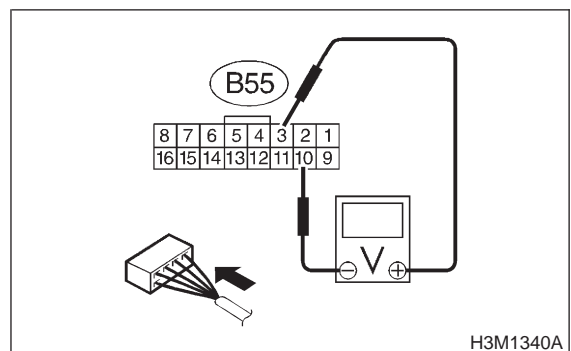

- CHECK** : Is the voltage less than 1 V in "P" range?
YES : Go to step 8K9.
NO : Go to step 8K12.

8K9 : CHECK OUTPUT SIGNAL EMITTED FROM TCM.

Measure voltage between TCM connector terminals.

Connector & terminal
(B55) No. 3 (+) — No. 10 (-):

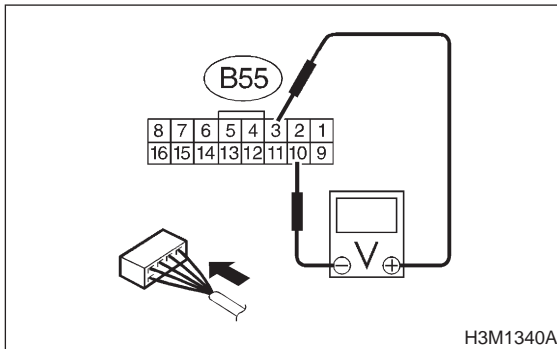

- CHECK** : *Is the voltage between 5 and 7 V in "D" range?*
- YES** : Even if "AT OIL TEMP" lights up, the circuit has returned to a normal condition at this time. A temporary poor contact of the connector or harness may be the cause. Repair harness or connector in the duty solenoid C and TCM connector.
- NO** : Go to step **8K12**.

8K10 : CHECK OUTPUT SIGNAL EMITTED FROM TCM USING SUBARU SELECT MONITOR.

- 1) Connect connectors to TCM and transmission.
- 2) Install air intake chamber.
- 3) Connect Subaru Select Monitor to data link connector.

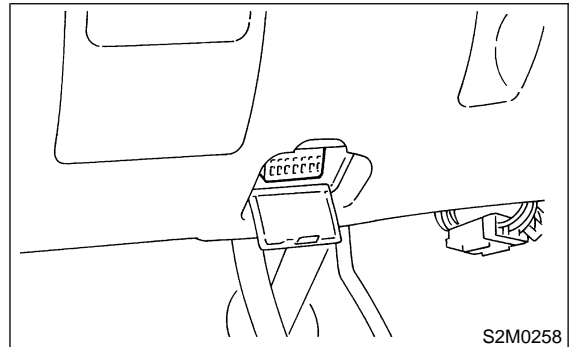

- 4) Turn ignition switch to ON (engine OFF) and turn Subaru Select Monitor switch to ON.
 - 5) Move selector lever to "D" with throttle fully open (vehicle speed 0 km/h or 0 m/h).
 - 6) Read data of duty solenoid C using Subaru Select Monitor.
 - Duty solenoid C is indicated in "%".
- CHECK** : *Is the value between 5 and 10%?*
 - YES** : Go to step **8K11**.
 - NO** : Go to step **8K12**.

8K11 : CHECK OUTPUT SIGNAL EMITTED FROM TCM USING SUBARU SELECT MONITOR.

- 1) Set FWD mode.
 - 2) Throttle fully closed.
- CHECK** : *Is the value 95%?*
 - YES** : Even if "AT OIL TEMP" lights up, the circuit has returned to a normal condition at this time. A temporary poor contact of the connector or harness may be the cause. Repair harness or connector in the duty solenoid C and TCM connector.
 - NO** : Go to step **8K12**.

8K12 : CHECK POOR CONTACT.

- CHECK** : *Is there poor contact in duty solenoid C circuit?*
- YES** : Repair poor contact.
- NO** : Replace TCM.

3-2 [T8K13] AUTOMATIC TRANSMISSION AND DIFFERENTIAL

8. Diagnostic Chart with Trouble Code

8K13 : CHECK DUTY SOLENOID C (IN TRANSMISSION).

1) Lift-up the vehicle and place safety stand.

CAUTION:

On AWD models, raise all wheels off ground.

2) Drain automatic transmission fluid.

CAUTION:

Do not drain the automatic transmission fluid until it cools down.

3) Remove extension case, and disconnect connector from duty solenoid C.

<Ref. to 3-2 [W6A0].>

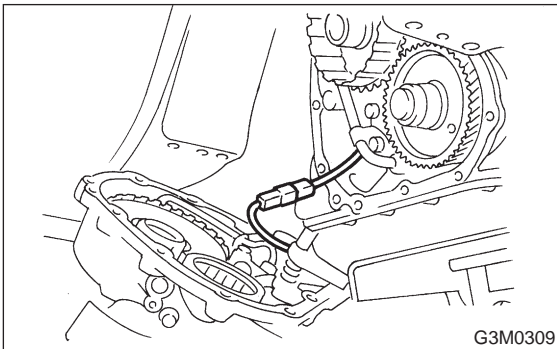

4) Measure resistance between duty solenoid C connector and transmission ground.

Connector & terminal

(AT4) No. 1 — Transmission ground:

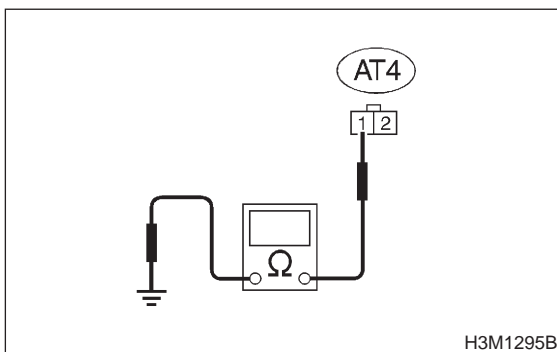

CHECK : **Is the resistance between 9 and 17 Ω?**

YES : Go to step **8K14**.

NO : Replace duty solenoid C.

8K14 : CHECK HARNESS CONNECTOR BETWEEN DUTY SOLENOID C AND TRANSMISSION.

Measure resistance of harness between duty solenoid C and transmission connector.

Connector & terminal

(T4) No. 11 — (AT4) No. 1:

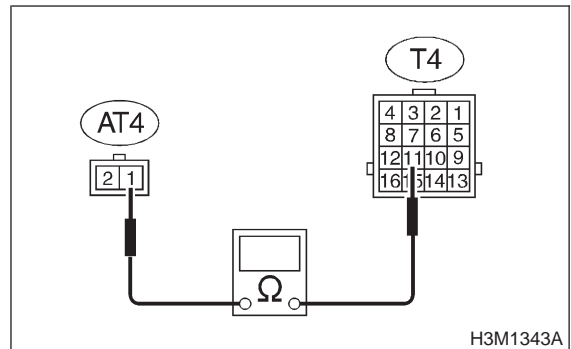

CHECK : **Is the resistance less than 1 Ω?**

YES : Go to step **8K15**.

NO : Repair open circuit in harness between duty solenoid C and transmission connector.

8K15 : CHECK HARNESS CONNECTOR BETWEEN DUTY SOLENOID C AND TRANSMISSION.

Measure resistance of harness between transmission connector and transmission ground.

Connector & terminal

(T4) No. 11 — Transmission ground:

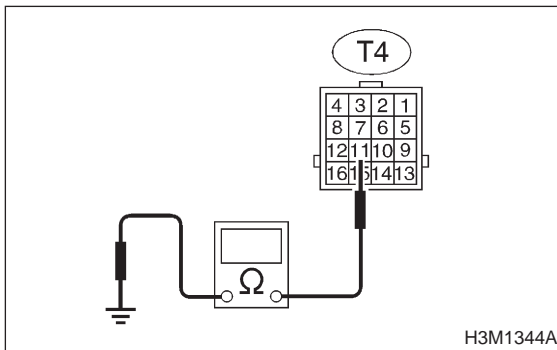

- CHECK** : **Is the resistance more than 1 MΩ?**
- YES** : Even if "AT OIL TEMP" lights up, the circuit has returned to a normal condition at this time. A temporary poor contact of the connector or harness may be the cause. Repair harness or contact in the duty solenoid C and transmission connector.
- NO** : Repair short circuit in harness between duty solenoid C and transmission connector.

3-2 [T8L0] AUTOMATIC TRANSMISSION AND DIFFERENTIAL

8. Diagnostic Chart with Trouble Code

L: TROUBLE CODE 25 — TORQUE CONTROL SIGNAL —

DIAGNOSIS:

- Torque control signal is not emitted from TCM.
- The signal circuit is open or shorted.

TROUBLE SYMPTOM:

Excessive shift shock.

WIRING DIAGRAM:

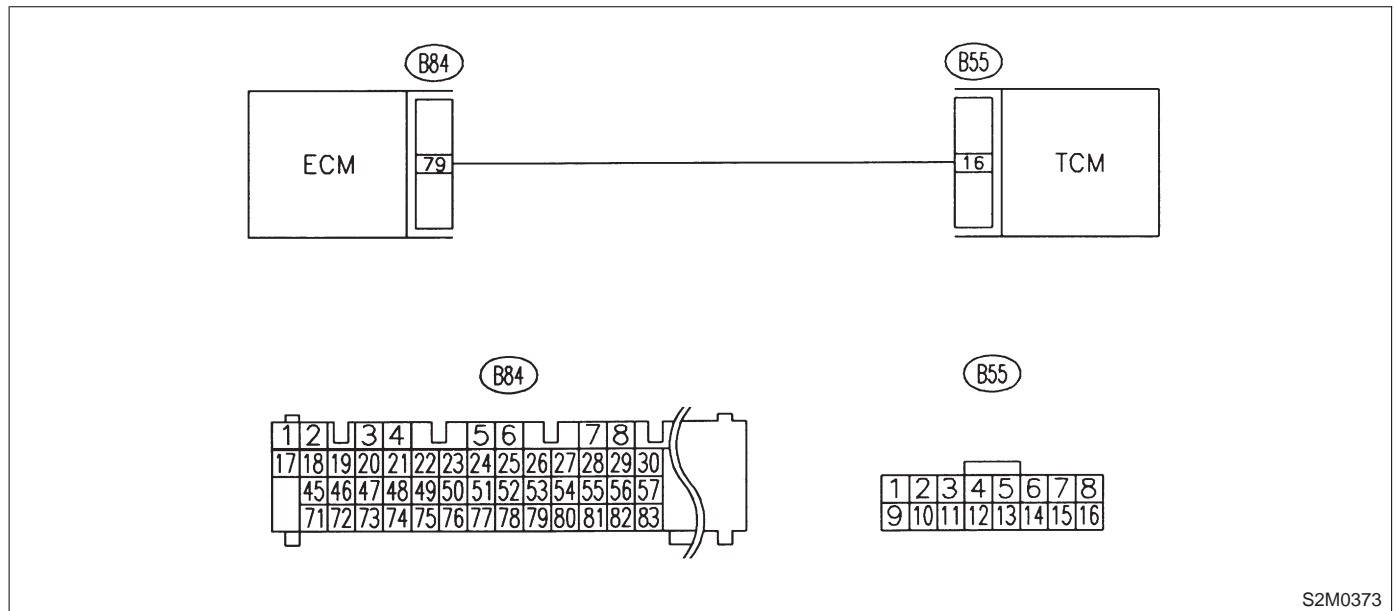

8L1 : CHECK HARNESS CONNECTOR BETWEEN TCM AND ECM.

- 1) Turn ignition switch to OFF.
- 2) Disconnect connectors from TCM and ECM.
- 3) Measure resistance of harness between TCM and ECM connector.

Connector & terminal

(B55) No. 16 — (B84) No. 79:

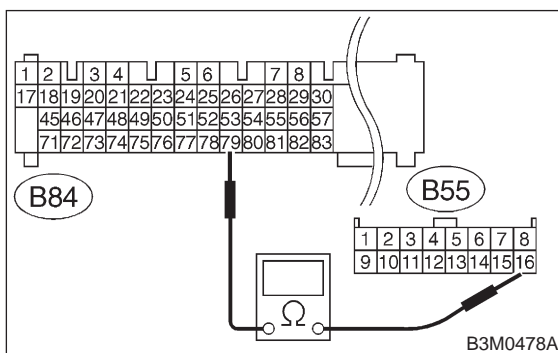

- CHECK** : Is the resistance less than 1 Ω?
- YES** : Go to step 8L2.
- NO** : Repair open circuit in harness between TCM and ECM connector.

8L2 : CHECK HARNESS CONNECTOR BETWEEN TCM AND ECM.

Measure resistance of harness between TCM connector and chassis ground.

Connector & terminal

(B55) No. 16 — Chassis ground:

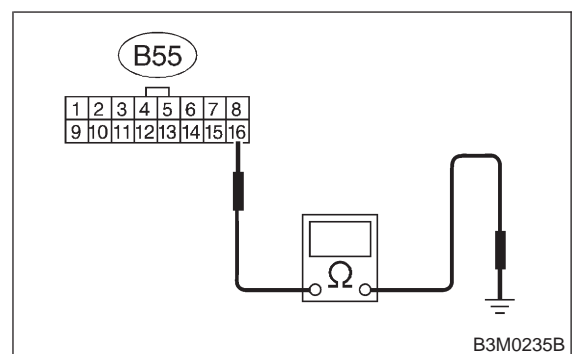

- CHECK** : Is the resistance more than 1 MΩ?
- YES** : Go to step 8L3.
- NO** : Repair short circuit in harness between TCM and ECM connector.

8L3 : CHECK OUTPUT SIGNAL EMITTED FROM TCM.

- 1) Connect connectors to TCM and ECM.
- 2) Turn ignition switch to ON (engine OFF).
- 3) Measure voltage between TCM connector terminals.

Connector & terminal

(B55) No. 16 (+) — No. 10 (-):

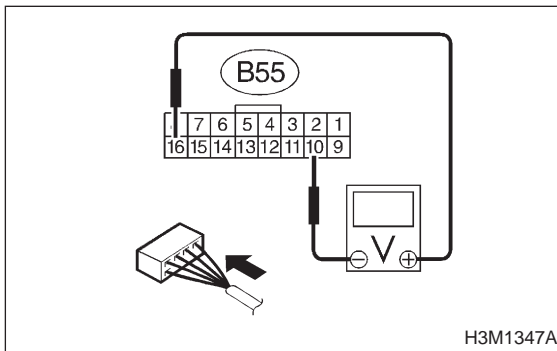

- CHECK** : **Is the voltage between 4 and 6 V?**
- YES** : Even if "AT OIL TEMP" lights up, the circuit has returned to a normal condition at this time. A temporary poor contact of the connector or harness may be the cause. Repair harness or connector in the TCM and ECM.
- NO** : Go to step **8L4**.

8L4 : CHECK POOR CONTACT.

- CHECK** : **Is there poor contact in torque control signal circuit?**
- YES** : Repair poor contact.
- NO** : Go to step **8L5**.

8L5 : CONFIRM TROUBLE CODE 25.

- CHECK** : **Replace ECM with a new one. Does the trouble code appear again, after the memory has been cleared?**
- YES** : Replace TCM.
- NO** : Replace ECM.

3-2 [T8M0] AUTOMATIC TRANSMISSION AND DIFFERENTIAL

8. Diagnostic Chart with Trouble Code

M: TROUBLE CODE 31 — THROTTLE POSITION SENSOR —

DIAGNOSIS:

Input signal circuit of throttle position sensor is open or shorted.

TROUBLE SYMPTOM:

Shift point too high or too low; engine brake not effected in “3” range: excessive shift shock; excessive tight corner “braking”.

WIRING DIAGRAM:

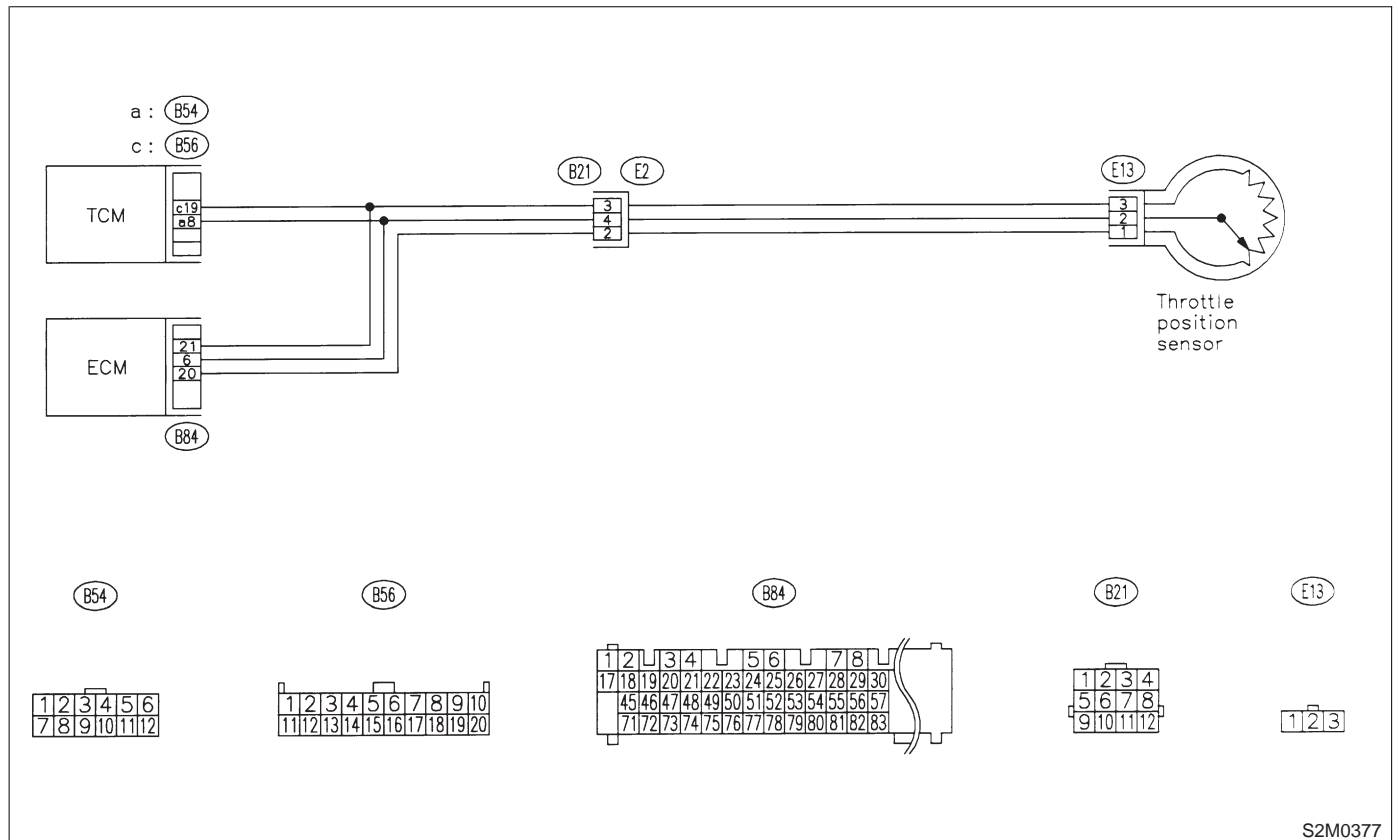

S2M0377

8M1 : CHECK THROTTLE POSITION SENSOR.

- 1) Turn ignition switch to OFF.
- 2) Remove air intake chamber.
- 3) Disconnect connector from throttle position sensor.
- 4) Measure resistance between throttle position sensor connector receptacle's terminals.

Terminals

No. 1 — No. 2:

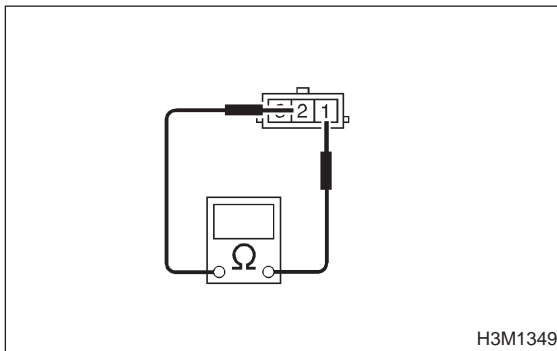

- CHECK** : Is the resistance between 0.3 and 0.7 kΩ?
- YES** : Go to step 8M2.
- NO** : Replace throttle position sensor.

8M2 : CHECK THROTTLE POSITION SENSOR.

Measure resistance between throttle position sensor connector receptacle's terminals.

Terminals

No. 1 — No. 3:

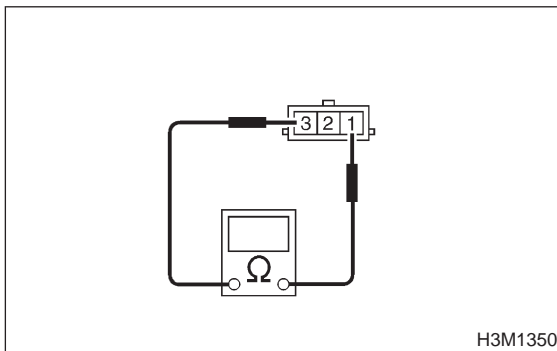

- CHECK** : Is the resistance between 3.5 and 6.5 kΩ?
- YES** : Go to step 8M3.
- NO** : Replace throttle position sensor.

8M3 : CHECK HARNESS CONNECTOR BETWEEN TCM AND THROTTLE POSITION SENSOR.

- 1) Disconnect connector from TCM.
- 2) Measure resistance of harness between TCM and throttle position sensor connector.

Connector & terminal

(B54) No. 8 — (E13) No. 2:

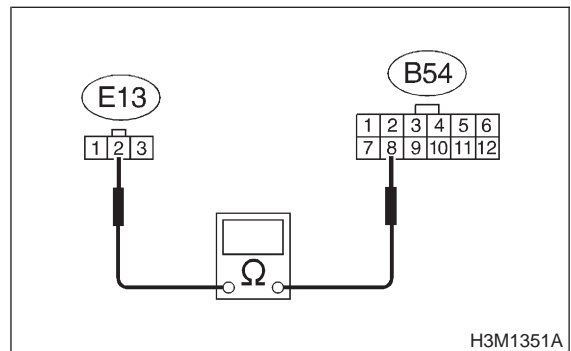

- CHECK** : Is the resistance less than 1 Ω?
- YES** : Go to step 8M4.
- NO** : Repair open circuit in harness between TCM and throttle position sensor connector.

8M4 : CHECK HARNESS CONNECTOR BETWEEN TCM AND THROTTLE POSITION SENSOR.

Measure resistance of harness between TCM and throttle position sensor connector.

Connector & terminal

(B56) No. 19 — (E13) No. 3:

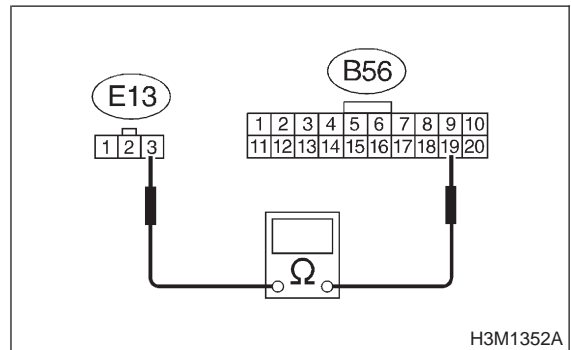

- CHECK** : Is the resistance less than 1 Ω?
- YES** : Go to step 8M5.
- NO** : Repair open circuit in harness between TCM and throttle position sensor connector.

3-2 [T8M5] AUTOMATIC TRANSMISSION AND DIFFERENTIAL

8. Diagnostic Chart with Trouble Code

8M5 : CHECK HARNESS CONNECTOR BETWEEN TCM AND THROTTLE POSITION SENSOR.

Measure resistance of harness between TCM connector and chassis ground.

Connector & terminal

(B54) No. 8 — Chassis ground:

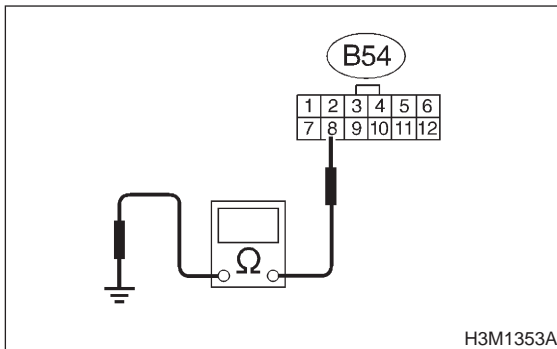

- CHECK** : Is the resistance more than 1 MΩ?
YES : Go to step 8M6.
NO : Repair short circuit in harness between TCM and throttle position sensor connector.

8M6 : CHECK HARNESS CONNECTOR BETWEEN TCM AND THROTTLE POSITION SENSOR.

Measure resistance of harness between TCM connector and chassis ground.

Connector & terminal

(B56) No. 19 — Chassis ground:

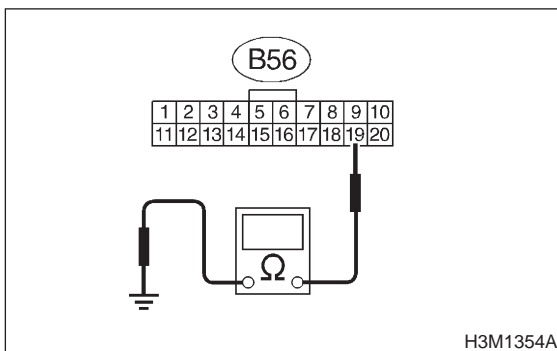

- CHECK** : Is the resistance more than 1 MΩ?
YES : Go to step 8M7.
NO : Repair short circuit in harness between TCM and throttle position sensor connector.

8M7 : CHECK HARNESS CONNECTOR BETWEEN TCM AND ECM.

- 1) Disconnect connector from ECM.
- 2) Measure resistance of harness between TCM and ECM connector.

Connector & terminal

(B54) No. 8 — (B84) No. 6:

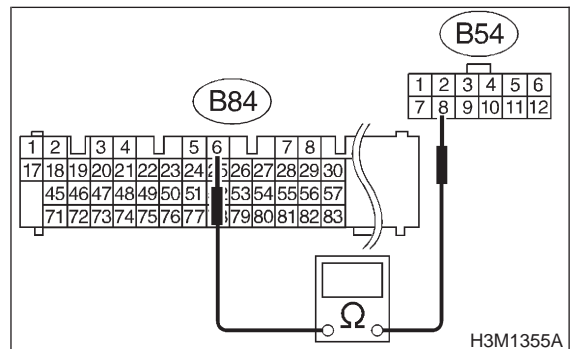

- CHECK** : Is the resistance less than 1 Ω?
YES : Go to step 8M8.
NO : Repair open circuit in harness between TCM and ECM connector.

8M8 : CHECK HARNESS CONNECTOR BETWEEN TCM AND ECM.

Measure resistance of harness between TCM and ECM connector.

Connector & terminal

(B56) No. 19 — (B84) No. 21:

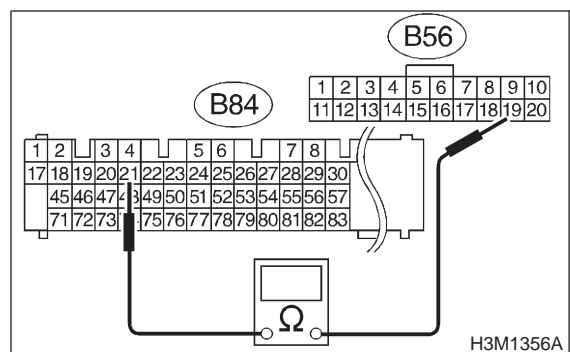

- CHECK** : Is the resistance less than 1 Ω?
YES : Go to step 8M9.
NO : Repair open circuit in harness between TCM and ECM connector.

8M9 : PREPARE SUBARU SELECT MONITOR.

- CHECK** : *Do you have a Subaru Select Monitor?*
- YES** : Go to step **8M12**.
- NO** : Go to step **8M10**.

8M10 : CHECK INPUT SIGNAL FOR TCM.

- 1) Connect connectors to TCM, throttle position sensor and ECM.
- 2) Install air intake chamber.
- 3) Turn ignition switch to ON (engine OFF).
- 4) Measure voltage between TCM connector terminals.

Connector & terminal
(B54) No. 8 (+) — No. 7 (-):

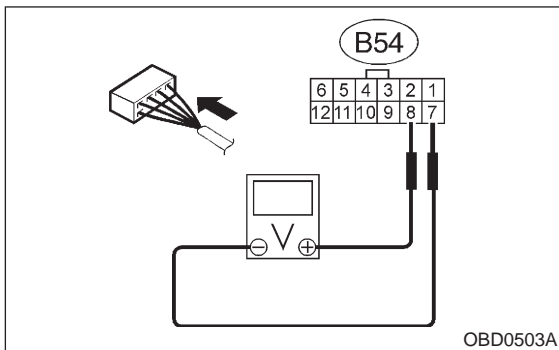

- CHECK** : *Is the voltage between 0.3 and 0.7 V in throttle fully closed?*
- YES** : Go to step **8M11**.
- NO** : Go to step **8M16**.

8M11 : CHECK INPUT SIGNAL FOR TCM.

Measure voltage between TCM connector terminals.

Connector & terminal
(B54) No. 8 (+) — No. 7 (-):

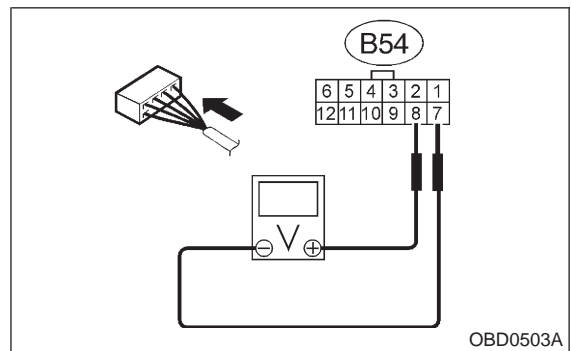

- CHECK** : *Is the voltage between 4.3 and 4.9 V with throttle fully open?*
- YES** : Go to step **8M14**.
- NO** : Go to step **8M16**.

8M12 : CHECK INPUT SIGNAL FOR TCM USING SUBARU SELECT MONITOR.

- 1) Connect connectors to TCM, throttle position sensor and ECM.
- 2) Install air intake chamber.
- 3) Connect Subaru Select Monitor to data link connector.

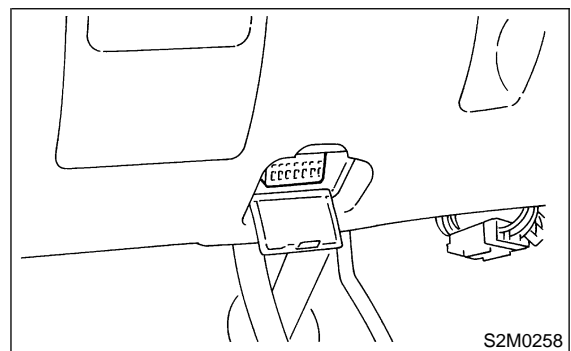

- 4) Turn ignition switch to ON (engine OFF).
- 5) Turn Subaru Select Monitor switch to ON.
- 6) Throttle fully closed.
- 7) Read data of throttle position sensor using Subaru Select Monitor.
 - Throttle position sensor input signal is indicated.

- CHECK** : *Is the value voltage between 0.3 and 0.7 V?*
- YES** : Go to step **8M13**.
- NO** : Go to step **8M16**.

3-2 [T8M13] AUTOMATIC TRANSMISSION AND DIFFERENTIAL

8. Diagnostic Chart with Trouble Code

8M13 : CHECK INPUT SIGNAL FOR TCM USING SUBARU SELECT MONITOR.

Throttle fully open.

NOTE:

Must be changed correspondingly with accelerator pedal operation (from "released" to "depressed" position).

CHECK : *Is the value voltage between 4.3 and 4.9 V ?*

YES : Go to step **8M14**.

NO : Go to step **8M16**.

8M14 : CHECK INPUT SIGNAL FOR TCM (THROTTLE POSITION SENSOR POWER SUPPLY).

Measure voltage between TCM connector terminals.

Connector & terminal

(B56) No. 19 (+) — (B84) No. 21 (-):

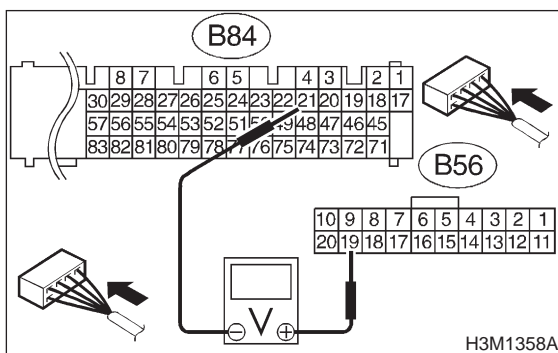

CHECK : *Is the voltage between 5.02 and 5.22 V?*

YES : Even if "AT OIL TEMP" lights up, the circuit has returned to a normal condition at this time. A temporary poor contact of the connector or harness may be the cause. Repair harness or connector in throttle position sensor circuit.

NO : Go to step **8M16**.

8M15 : CHECK INPUT SIGNAL FOR TCM USING SUBARU SELECT MONITOR (THROTTLE POSITION SENSOR POWER SUPPLY).

Read data of throttle position sensor power supply using Subaru Select Monitor.

● Throttle position sensor power supply voltage is indicated.

CHECK : *Is the value voltage between 5.02 and 5.22 V?*

YES : Even if "AT OIL TEMP" lights up, the circuit has returned to a normal condition at this time. A temporary poor contact of the connector or harness may be the cause. Repair harness or connector in throttle position sensor circuit.

NO : Go to step **8M16**.

8M16 : CHECK POOR CONTACT.

CHECK : *Is there poor contact in throttle position sensor circuit?*

YES : Repair poor contact.

NO : Replace TCM.

MEMO:

3-2 [T8N0] AUTOMATIC TRANSMISSION AND DIFFERENTIAL

8. Diagnostic Chart with Trouble Code

N: TROUBLE CODE 32 — VEHICLE SPEED SENSOR 1 —

DIAGNOSIS:

Input signal circuit of TCM is open or shorted.

TROUBLE SYMPTOM:

No lock-up or excessive tight corner "braking".

WIRING DIAGRAM:

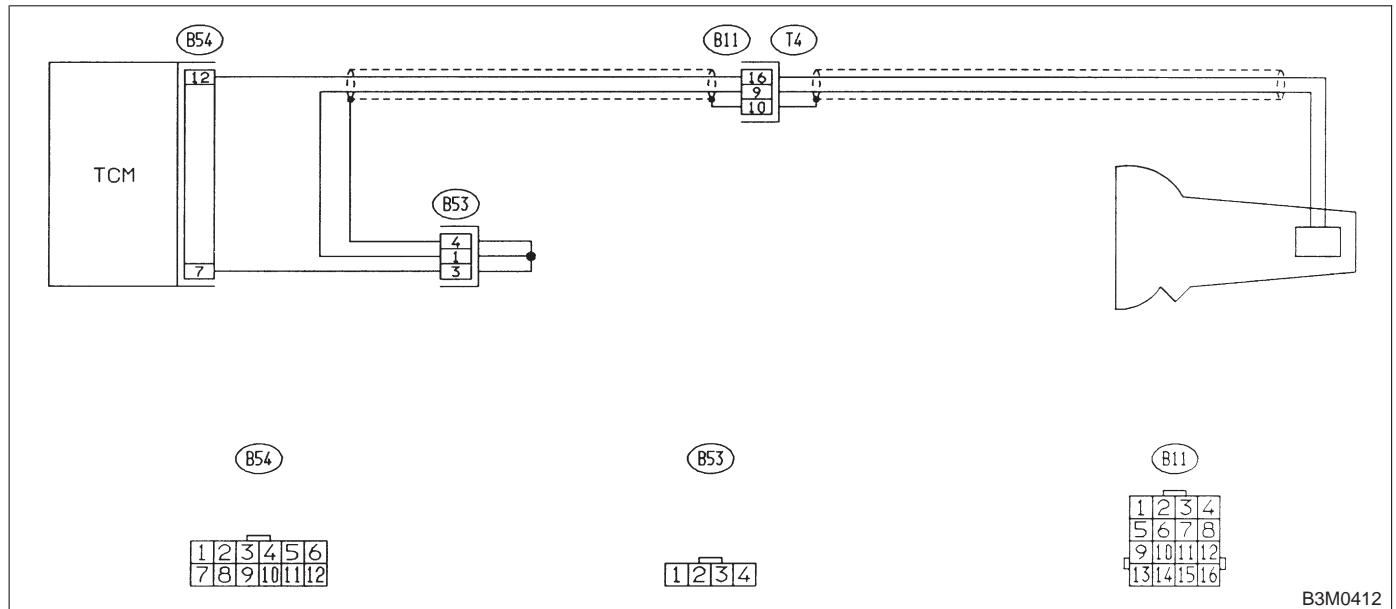

8N1 : CHECK VEHICLE SPEED SENSOR 1.

- 1) Turn ignition switch to OFF.
- 2) Remove air intake chamber.
- 3) Disconnect connector from transmission.
- 4) Measure resistance between transmission connector receptacle's terminals.

Connector & terminal

(T4) No. 16 — No. 9:

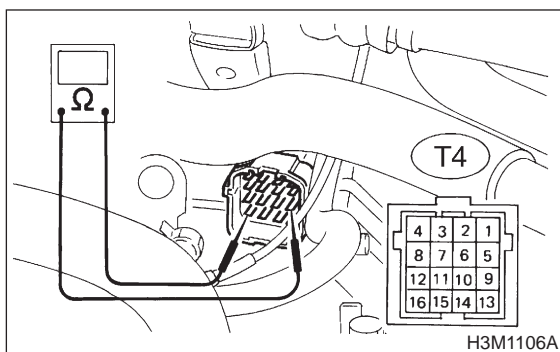

CHECK : Is the resistance between 450 and 720 Ω ?

YES : Go to step 8N2.

NO : Replace vehicle speed sensor 1.

8N2 : CHECK HARNESS CONNECTOR BETWEEN TCM AND TRANSMISSION.

- 1) Disconnect connector from TCM.
- 2) Measure resistance of harness between TCM and transmission connector.

Connector & terminal

(B54) No. 12 — (B11) No. 16:

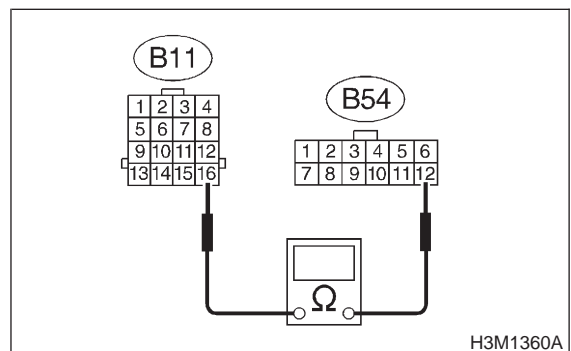

CHECK : Is the resistance less than 1 Ω ?

YES : Go to step 8N3.

NO : Repair open circuit in harness between TCM and transmission connector.

8N3 : CHECK HARNESS CONNECTOR BETWEEN TCM AND TRANSMISSION.

Measure resistance of harness between TCM and transmission connector.

Connector & terminal
(B54) No. 7 — (B11) No. 9:

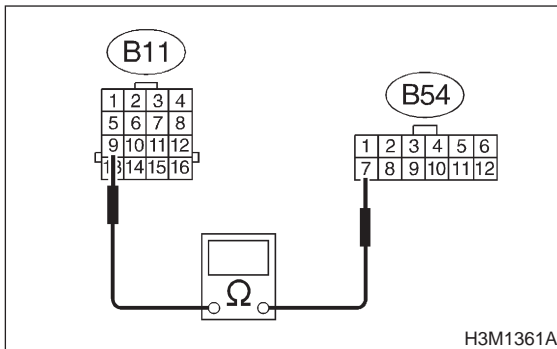

- CHECK** : *Is the resistance less than 1 Ω?*
- YES** : Go to step **8N4**.
- NO** : Repair open circuit in harness between TCM and transmission connector.

8N4 : CHECK HARNESS CONNECTOR BETWEEN TCM AND TRANSMISSION.

Measure resistance of harness between TCM and transmission connector.

Connector & terminal
(B54) No. 7 — Chassis ground:

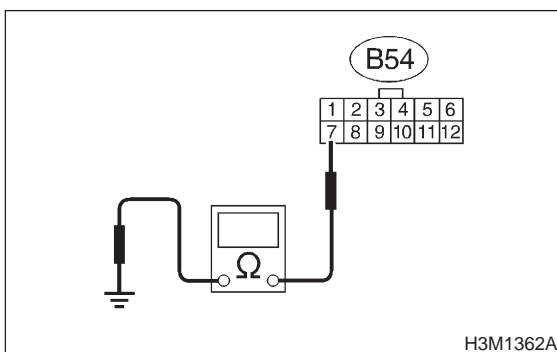

- CHECK** : *Is the resistance more than 1 MΩ?*
- YES** : Go to step **8N5**.
- NO** : Repair short circuit in harness between TCM and transmission connector.

8N5 : CHECK HARNESS CONNECTOR BETWEEN TCM AND TRANSMISSION.

Measure resistance of harness between TCM and transmission connector.

Connector & terminal
(B54) No. 12 — Chassis ground:

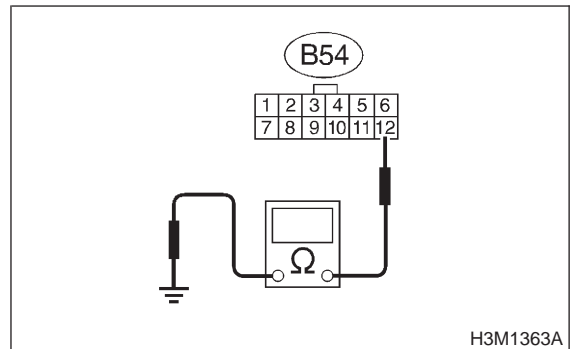

- CHECK** : *Is the resistance more than 1 MΩ?*
- YES** : Go to step **8N6**.
- NO** : Repair short circuit in harness between TCM and transmission connector.

8N6 : PREPARE OSCILLOSCOPE.

- CHECK** : *Do you have oscilloscope?*
- YES** : Go to step **8N10**.
- NO** : Go to step **8N7**.

8N7 : PREPARE SUBARU SELECT MONITOR.

- CHECK** : *Do you have a Subaru Select Monitor?*
- YES** : Go to step **8N9**.
- NO** : Go to step **8N8**.

3-2 [T8N8] AUTOMATIC TRANSMISSION AND DIFFERENTIAL

8. Diagnostic Chart with Trouble Code

8N8 : CHECK INPUT SIGNAL FOR TCM.

- 1) Connect connectors to TCM and transmission.
- 2) Install air intake chamber.
- 3) Lift-up or raise the vehicle and place safety stands.

CAUTION:

On AWD models, raise all wheels off floor.

- 4) Start the engine and set vehicle in 20 km/h (12 m/h) condition.

NOTE:

The speed difference between front and rear wheels may light the ABS warning light, but this indicates no malfunction. When AT control diagnosis is finished, perform the ABS memory clearance procedure of on-board diagnostics system. <Ref. to 4-4 [T6D2].>

- 5) Measure voltage between TCM connector terminals.

Connector & terminal

(B54) No. 12 (+) — No. 7 (-):

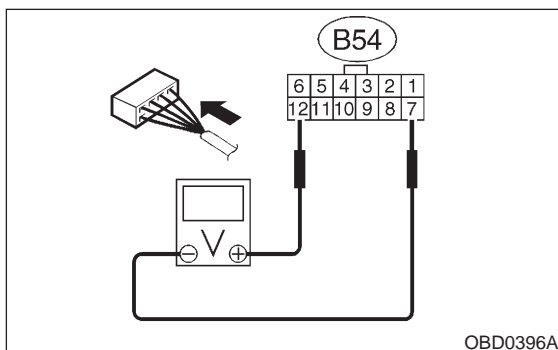

CHECK : **Is the voltage more than AC 1 V?**

YES : Even if "AT OIL TEMP" lights up, the circuit has returned to a normal condition at this time. A temporary poor contact of the connector or harness may be the cause. Repair harness or connector in the TCM and transmission.

NO : Go to step **8N11**.

8N9 : CHECK INPUT SIGNAL FOR TCM USING SUBARU SELECT MONITOR.

- 1) Connect connectors to TCM and transmission.
- 2) Install air intake chamber.
- 3) Connect Subaru Select Monitor to data link connector.

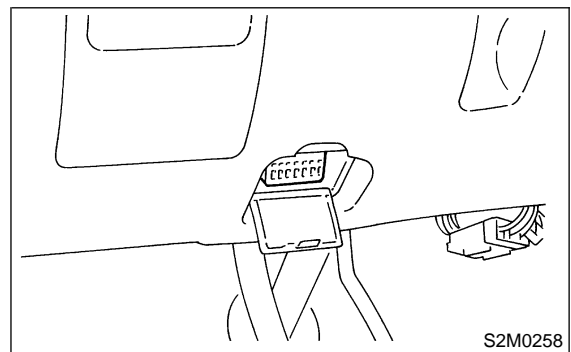

- 4) Lift-up or raise the vehicle and place safety stands.

CAUTION:

On AWD models, raise all wheels off floor.

- 5) Turn ignition switch to ON and turn Subaru Select Monitor switch to ON.

- 6) Start the engine.

- 7) Read data of vehicle speed using Subaru Select Monitor.

- Compare speedometer with Subaru Select Monitor indications.

- Vehicle speed is indicated in "km/h" or "MPH".

- 8) Slowly increase vehicle speed to 60 km/h or 37 MPH.

NOTE:

The speed difference between front and rear wheels may light the ABS warning light, but this indicates no malfunction. When AT control diagnosis is finished, perform the ABS memory clearance procedure of on-board diagnostics system. <Ref. to 4-4 [T6D2].>

CHECK : **Does the speedometer indication increase as the Subaru Select Monitor data increases?**

YES : Even if "AT OIL TEMP" lights up, the circuit has returned to a normal condition at this time. A temporary poor contact of the connector or harness may be the cause. Repair harness or connector in the TCM and transmission.

NO : Go to step **8N11**.

8N10 : CHECK INPUT SIGNAL FOR TCM USING OSCILLOSCOPE.

- 1) Connect connectors to TCM and transmission.
- 2) Install air intake chamber.
- 3) Lift-up or raise the vehicle and place safety stands.

CAUTION:

On AWD models, raise all wheels off floor.

- 4) Set oscilloscope to TCM connector terminals.
Position probe; (B54) No. 12
Earth lead; (B54) No. 7

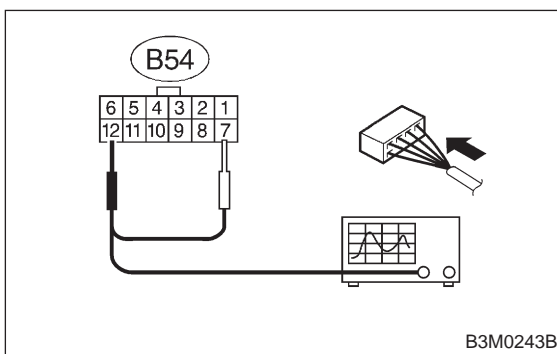

- 5) Start the engine and set vehicle in 20 km/h (12 m/h) condition.

NOTE:

The speed difference between front and rear wheels may light the ABS warning light, but this indicates no malfunction. When AT control diagnosis is finished, perform the ABS memory clearance procedure of on-board diagnostics system. <Ref. to 4-4 [T6D2].>

- 6) Measure signal voltage indicated on oscilloscope.

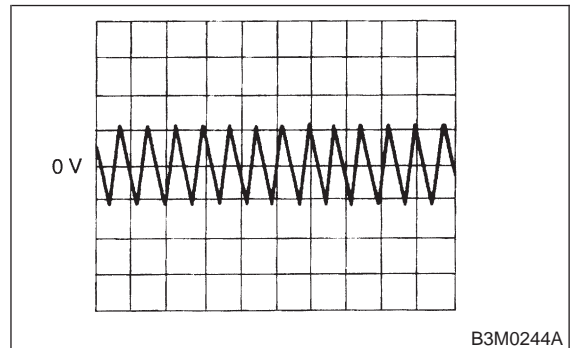

- CHECK** : *Is the signal voltage more than AC 1 V?*
- YES** : Even if "AT OIL TEMP" lights up, the circuit has returned to a normal condition at this time. A temporary poor contact of the connector or harness may be the cause. Repair harness or connector in the TCM and transmission.
- NO** : Go to step **8N11**.

8N11 : CHECK POOR CONTACT.

- CHECK** : *Is there poor contact in vehicle speed sensor 1 circuit?*
- YES** : Repair poor contact.
- NO** : Replace TCM.

3-2 [T800] AUTOMATIC TRANSMISSION AND DIFFERENTIAL

8. Diagnostic Chart with Trouble Code

O: TROUBLE CODE 33 — VEHICLE SPEED SENSOR 2 —

DIAGNOSIS:

- The vehicle speed signal is abnormal.
- The circuit in combination meter is faulty.
- The harness connector between TCM and vehicle speed sensor is in short or open.

TROUBLE SYMPTOM:

- Erroneous idling.
- Engine stalls.
- Poor driving performance.

WIRING DIAGRAM:

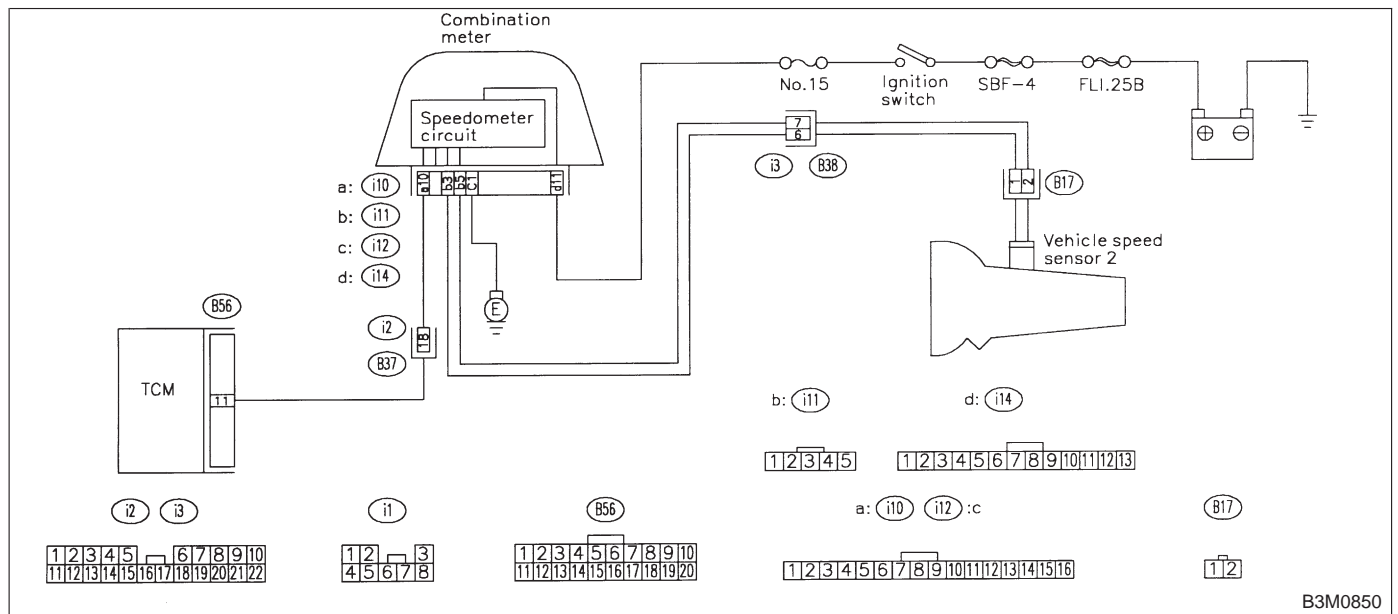

B3M0850

801 : CHECK OPERATION OF SPEEDOMETER.

- CHECK** : Does speedometer operate normally?
- YES** : Go to step 802.
- NO** : Check speedometer. <Ref. to 6-2b [T300].>

802 : CHECK HARNESS CONNECTOR BETWEEN TCM AND COMBINATION METER.

- 1) Turn ignition switch to OFF.
- 2) Remove combination meter.
- 3) Disconnect connectors from TCM and combination meter.
- 4) Measure resistance of harness between TCM and combination meter connector.

Connector & terminal
(B56) No. 11 — (i10) No. 10:

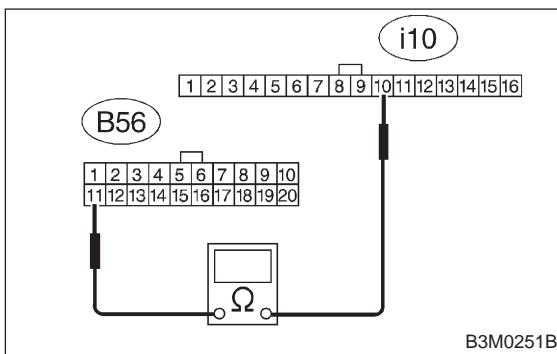

- CHECK** : *Is the resistance less than 1 Ω?*
- YES** : Go to step **803**.
- NO** : Repair open circuit in harness between TCM and combination meter connector, and poor contact in coupling connector.

803 : CHECK HARNESS CONNECTOR BETWEEN TCM AND COMBINATION METER.

Measure resistance of harness between combination meter and chassis ground.

Connector & terminal
(i10) No. 10 — Chassis ground:

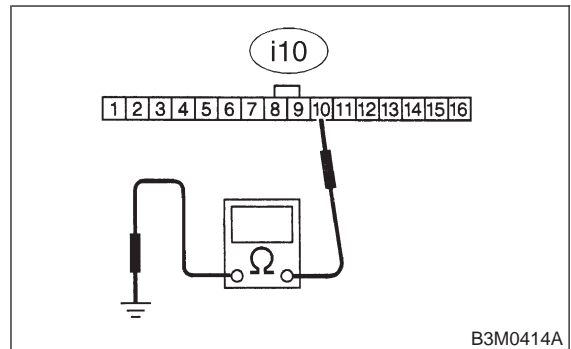

- CHECK** : *Is the resistance more than 1 MΩ?*
- YES** : Go to step **804**.
- NO** : Repair short circuit in harness between TCM and combination meter connector.

3-2 [T804] AUTOMATIC TRANSMISSION AND DIFFERENTIAL

8. Diagnostic Chart with Trouble Code

804 : CHECK VEHICLE SPEED SENSOR 2.

- 1) Install combination meter.
- 2) Connect connector to TCM.
- 3) Lift-up the vehicle and place safety stand.

CAUTION:

On AWD models, raise all wheels off floor.

- 4) Disconnect connector from vehicle speed sensor 2.
- 5) Measure resistance between terminals of vehicle speed sensor 2.

Terminals

No. 1 — No. 2:

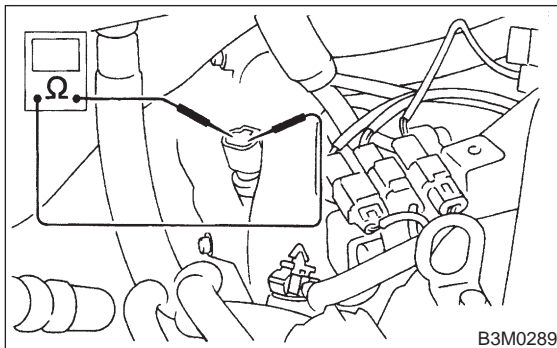

- CHECK** : Is the resistance between 350 and 450 Ω?
- YES** : Go to step 805.
- NO** : Replace vehicle speed sensor 2.

805 : CHECK VEHICLE SPEED SENSOR 2.

Measure resistance between terminals of vehicle speed sensor 2.

Terminals

No. 1 — Transmission ground:

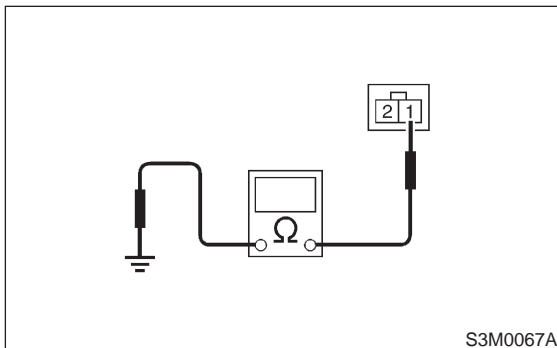

- CHECK** : Is the resistance more than 1 MΩ?
- YES** : Go to step 806.
- NO** : Replace vehicle speed sensor 2.

806 : CHECK VEHICLE SPEED SENSOR 2.

Measure resistance between terminals of vehicle speed sensor 2.

Terminals

No. 2 — Transmission ground:

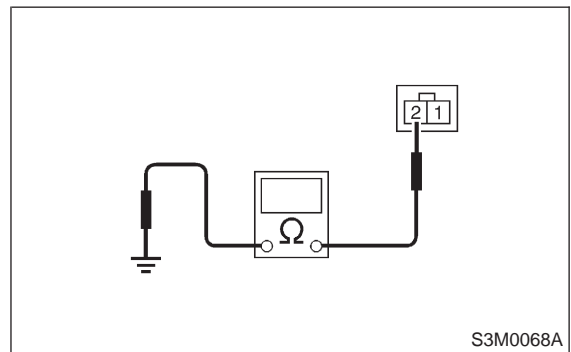

- CHECK** : Is the resistance more than 1 MΩ?
- YES** : Go to step 807.
- NO** : Replace vehicle speed sensor 2.

807 : PREPARE OSCILLOSCOPE.

- CHECK** : Do you have oscilloscope?
- YES** : Go to step 809.
- NO** : Go to step 808.

808 : CHECK VEHICLE SPEED SENSOR 2.

1) Start the engine and set vehicle in 20 km/h (12 MPH) condition.

NOTE:

The speed difference between front and rear wheels may light the ABS warning light, but this indicates no malfunctions. When AT control diagnosis is finished, perform the ABS memory clearance procedure of self-diagnosis system. <Ref. to 4-4 [T6D2].>

2) Measure output signal of vehicle speed sensor 2.

WARNING:

Be careful not to be caught up by the running wheels.

3) Measure voltage between terminals of vehicle speed sensor 2.

Terminals

No. 1 — No. 2:

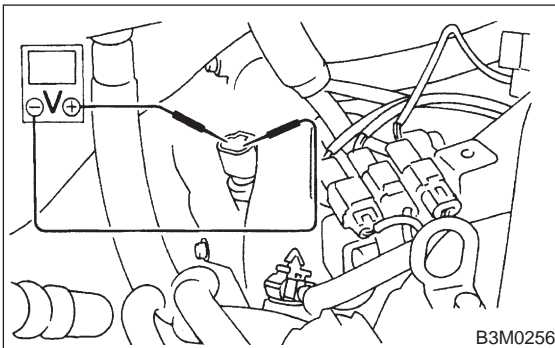

- CHECK** : **Is the voltage more than AC 2 V?**
- YES** : Go to step **8010**.
- NO** : Replace vehicle speed sensor 2.

809 : CHECK VEHICLE SPEED SENSOR 2 USING OSCILLOSCOPE.

- 1) Install combination meter.
- 2) Connect connector to TCM.
- 3) Lift-up the vehicle and place safety stand.

CAUTION:

On AWD models, raise all wheels off ground.

- 4) Set oscilloscope to vehicle speed sensor 2.

Terminals

No. 1 — No. 2:

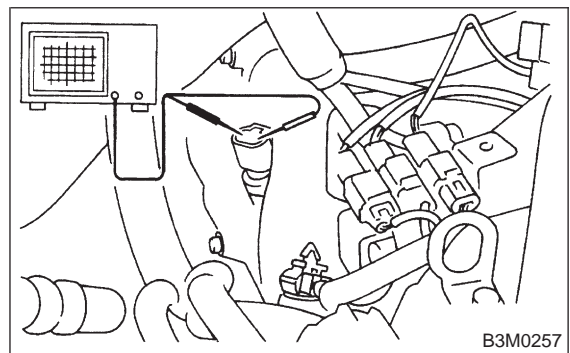

- 5) Start the engine, and drive the wheels slowly.

NOTE:

The speed difference between front and rear wheels may light the ABS warning light, but this indicates no malfunctions. When AT control diagnosis is finished, perform the ABS memory clearance procedure of self-diagnosis system. <Ref. to 4-4 [T6D2].>

- 6) Measure signal voltage indicated on oscilloscope.

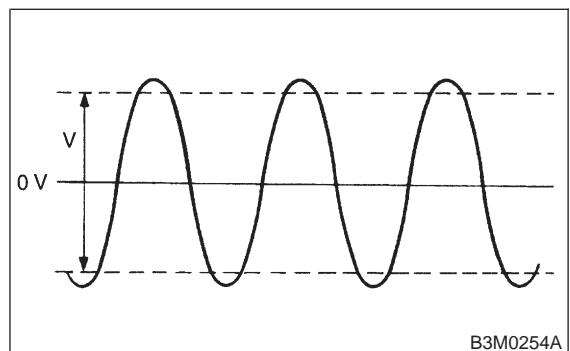

- CHECK** : **Is the voltage more than AC 2 V?**
- YES** : Go to step **8013**.
- NO** : Replace vehicle speed sensor 2.

3-2 [T8010] AUTOMATIC TRANSMISSION AND DIFFERENTIAL

8. Diagnostic Chart with Trouble Code

8010 : PREPARE SUBARU SELECT MONITOR.

CHECK : *Do you have a Subaru Select Monitor?*

YES : Go to step 8012.

NO : Go to step 8011.

8011 : CHECK INPUT SIGNAL FOR TCM.

- 1) Connect connectors to TCM and combination meter.
- 2) Install combination meter.
- 3) Lift-up the vehicle and place safety stand.

CAUTION:

On AWD models, raise all wheels off ground.

- 4) Start the engine, and set vehicle in 10 km/h (6 m/h).

NOTE:

The speed difference between front and rear wheels may light the ABS warning light, but this indicates no malfunction. When AT control diagnosis is finished, perform the ABS memory clearance procedure of on-board diagnostics system. <Ref. to 4-4 [T6D2].>

- 5) Measure voltage between TCM connector terminals.

Connector & terminal

(B56) No. 11 (+) — (B55) No. 10 (-):

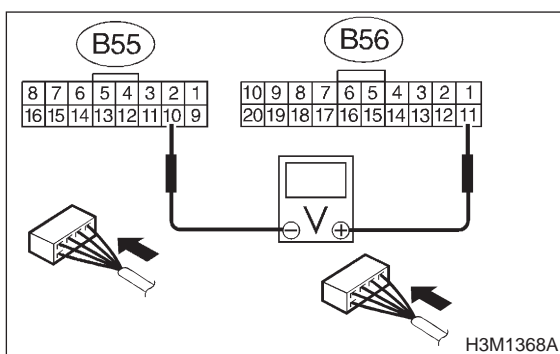

CHECK : *Is the voltage less than 1 V ⇔ more than 9 V?*

YES : Even if "AT OIL TEMP" lights up, the circuit has returned to a normal condition at this time. A temporary poor contact of the connector or harness may be the cause. Repair harness or connector in the TCM.

NO : Go to step 8014.

8012 : CHECK INPUT SIGNAL FOR TCM USING SUBARU SELECT MONITOR.

- 1) Connect connectors to TCM and combination meter.
- 2) Install combination meter.
- 3) Lift-up the vehicle and place safety stand.

CAUTION:

On AWD models, raise all wheels off ground.

- 4) Connect Subaru Select Monitor to data link connector.

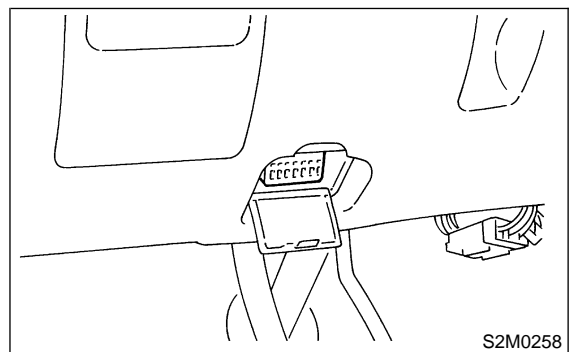

- 5) Turn ignition switch to ON and Subaru Select Monitor switch to ON.
- 6) Start the engine, and drive all wheels.
- 7) Read data of vehicle speed using Subaru Select Monitor.
 - Compare speedometer with Subaru Select Monitor indications.
 - Vehicle speed is indicated in "km/h" or "MPH".
- 8) Slowly increase vehicle speed to 60 km/h or 37 MPH.

NOTE:

The speed difference between front and rear wheels may light the ABS warning light, but this indicates no malfunction. When AT control diagnosis is finished, perform the ABS memory clearance procedure of on-board diagnostics system. <Ref. to 4-4 [T6D2].>

CHECK : *Does the speedometer indication increase as the Subaru Select Monitor data increases?*

YES : Even if "AT OIL TEMP" lights up, the circuit has returned to a normal condition at this time. A temporary poor contact of the connector or harness may be the cause. Repair harness or connector in the TCM.

NO : Go to step 8014.

8013 : CHECK INPUT SIGNAL FOR TCM USING OSCILLOSCOPE.

- 1) Connect connectors to TCM and combination meter.
- 2) Install combination meter.
- 3) Lift-up or raise the vehicle and place safety stands.

CAUTION:

On AWD models, raise all wheels off floor.

- 4) Set oscilloscope to TCM connector terminals. Positive probe; (B56) No. 11 Earth lead; (B55) No. 10

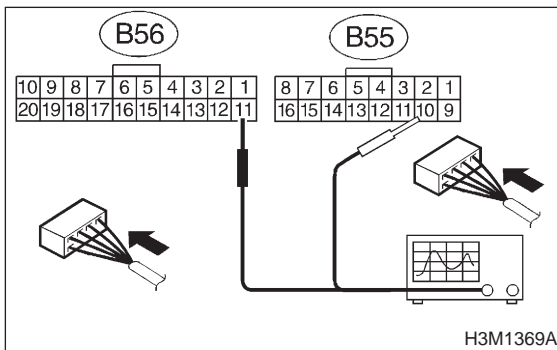

- 5) Start the engine.
- 6) Shift on the gear position, and keep the vehicle speed at constant.
- 7) Measure signal voltage indicated on oscilloscope.

NOTE:

- If vehicle speed increases, the width of amplitude (W) decreases.
- The speed difference between front and rear wheels may light the ABS warning light, but this indicates no malfunction. When AT control diagnosis is finished, perform the ABS memory clearance procedure of on-board diagnostics system. <Ref. to 4-4 [T6D2].>

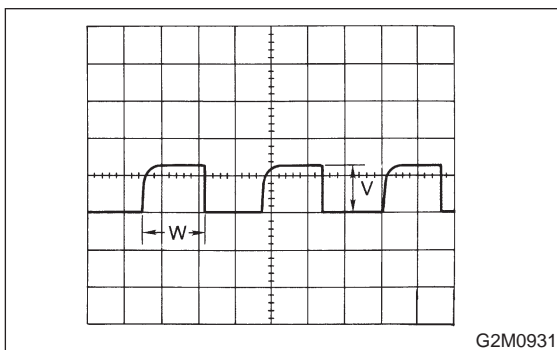

- CHECK** : **Is the voltage more than AC 2 V?**
- YES** : Even if "AT OIL TEMP" lights up, the circuit has returned to a normal condition at this time. A temporary poor con-

tact of the connector or harness may be the cause. Repair harness or connector in the TCM.

NO : Go to step **8014**.

8014 : CHECK POOR CONTACT.

CHECK : **Is there poor contact in vehicle speed sensor 2 circuit?**

YES : Repair poor contact.

NO : Replace TCM.