

## 8. Diagnostics Chart with Trouble Code

### A: DIAGNOSTIC TROUBLE CODE LIST

Diagnostic trouble code	Item	Contents of diagnosis	Index No.
11	BRAKE SWITCH/ STOP LIGHT SWITCH/ CLUTCH SWITCH (MT)/ INHIBITOR SWITCH (AT)	<ul style="list-style-type: none"> <li>● Input signals from brake switch OFF, stop light switch ON. (Brake pedal is depressed.)</li> <li>● Input signals from clutch switch OFF, or inhibitor switch is in "N" position. [Clutch pedal is depressed (MT), or selector lever is set to N position (AT).]</li> </ul>	<Ref. to 6-2a [T8B0].>
12	NO SET SPEED	Out of cruise speed range	<Ref. to 6-2a [T8C0].>
13	LOW SPEED LIMIT	Low-speed control limiter	<Ref. to 6-2a [T8C0].>
14	CANCEL SWITCH	Input signal from cancel switch	<Ref. to 6-2a [T8D0].>
15	NO MEMORY	No memorized cruise speed	—
21	SPEED SENSOR NG	Faulty vehicle speed sensor 2	<Ref. to 6-2a [T8C0].>
22	COMMAND SWITCH NG	Faulty SET/COAST switch or RESUME/ACCEL switch	<Ref. to 6-2a [T8D0].>
23	RELAY NG	Faulty safety relay included in cruise control module	<Ref. to 6-2a [T8E0].>
24	CPU RAM NG	Faulty CPU RAM included in cruise control module	<Ref. to 6-2a [T8E0].>
31	VACUUM MOTOR NG	Faulty vacuum motor or motor drive system	<Ref. to 6-2a [T8F0].>
32	AIR VALVE NG	Faulty air valve or valve drive system	<Ref. to 6-2a [T8F0].>
33	REL VALVE NG	Faulty release valve or valve drive system	<Ref. to 6-2a [T8F0].>

# 6-2a [T8B0] BODY ELECTRICAL SYSTEM (CRUISE CONTROL)

## 8. Diagnostics Chart with Trouble Code

### B: DIAGNOSTIC TROUBLE CODE 11 (BRAKE SWITCH, STOP LIGHT SWITCH, CLUTCH SWITCH (MT), INHIBITOR SWITCH (AT))

#### DIAGNOSIS:

- Failure or disconnection of the stop light switch and brake switch.
- Failure or disconnection of the clutch switch (MT).
- Failure or disconnection of the inhibitor switch (AT).

#### TROUBLE SYMPTOM:

- Cruise control cannot be set.

#### WIRING DIAGRAM:

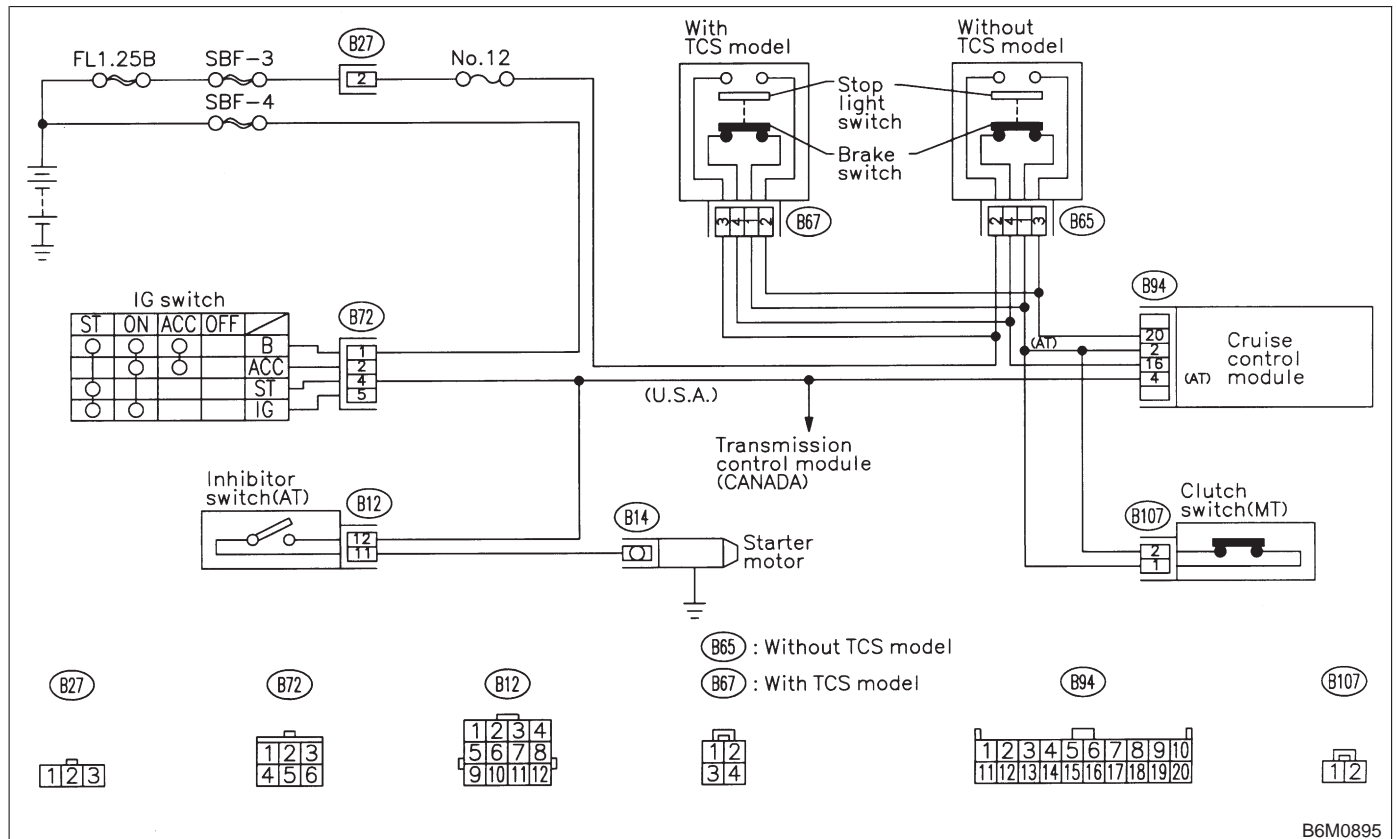

B6M0895

**8B1 : CHECK BRAKE SWITCH.**

- 1) Turn ignition switch to ON.
- 2) Turn cruise control main switch to ON.
- 3) Apply parking brake securely.
- 4) Set select monitor in "Current Data Display & Save" mode.
- 5) Release the clutch pedal. (MT)
- 6) Depress the brake pedal and check signals for proper operation.

(1) The Stop Lamp Switch shown on the display turns from "OFF" to "ON".

(2) The Brake Switch shown on the display turns from "OFF" to "ON".

- 7) Release the brake pedal.
- 8) Remove connector of stop and brake switch.
- 9) Check circuit between brake switch terminal.

**Terminals**

**No. 1 — No. 4: (Brake switch)**

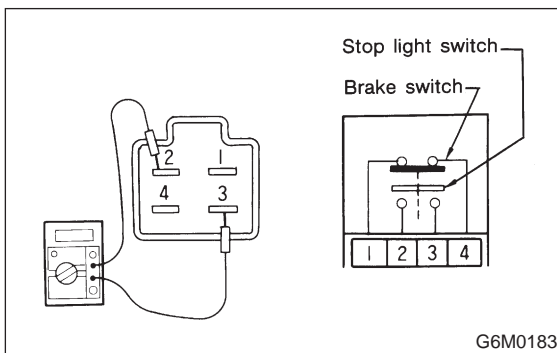

**CHECK** : *Is resistance less than 1 Ω? (When brake pedal is released.)*

**YES** : Go to step 8B2.

**NO** : Replace brake and stop light switch.

**8B2 : CHECK BRAKE SWITCH.**

Check circuit between brake switch terminal.

**Terminals**

**No. 1 — No. 4: (Brake switch)**

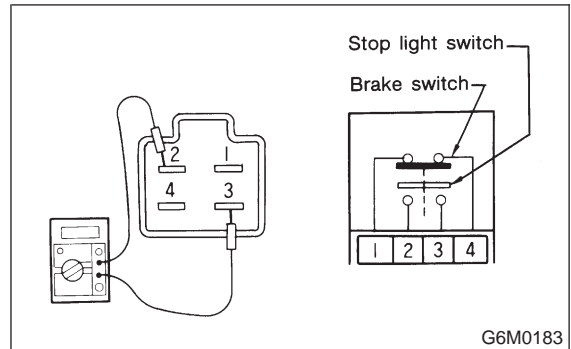

**CHECK** : *Is resistance more than 1 MΩ? (When brake pedal is depressed.)*

**YES** : Go to step 8B3.

**NO** : Replace brake and stop light switch.

**8B3 : CHECK STOP LIGHT SWITCH.**

Check circuit between stop light switch terminal.

**Terminals**

**No. 2 — No. 3: (Stop light switch)**

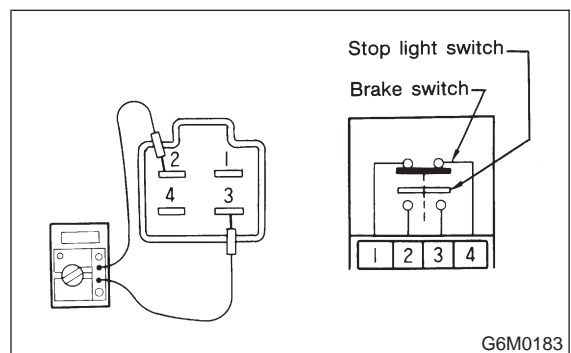

**CHECK** : *Is resistance more than 1 MΩ? (When brake pedal is released.)*

**YES** : Go to step 8B4.

**NO** : Replace brake and stop light switch.

## 6-2a [T8B4] BODY ELECTRICAL SYSTEM (CRUISE CONTROL)

### 8. Diagnostics Chart with Trouble Code

#### 8B4 : CHECK STOP LIGHT SWITCH.

Check circuit between stop light switch terminal.

##### Terminals

**No. 2 — No. 3: (Stop light switch)**

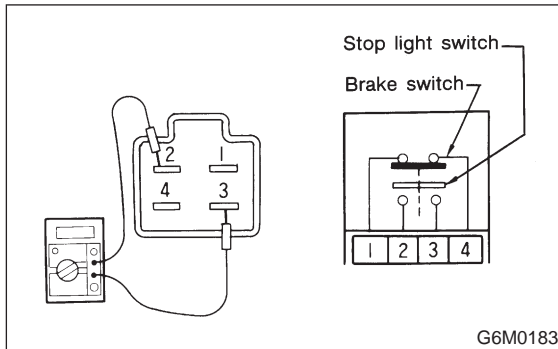

- CHECK** : *Is resistance less than 1  $\Omega$ ? (When brake pedal is depressed.)*
- YES** : (MT) Go to step 8B5. (AT) Go to step 8B7.
- NO** : Replace brake and stop light switch.

#### 8B5 : CHECK CLUTCH SWITCH. (MT)

- 1) Turn ignition switch to ON.
- 2) Turn cruise control main switch to ON.
- 3) Apply parking brake securely.
- 4) Set select monitor in "Current Data Display & Save" mode.
- 5) Depress the clutch pedal and check signal for proper operation.  
The Clutch/Inhibitor Switch shown on the display turns from "ON" to "OFF".
- 6) Disconnect connector of clutch switch.
- 7) Check continuity of the clutch switch.

##### Terminals

**No. 1 — No. 2:**

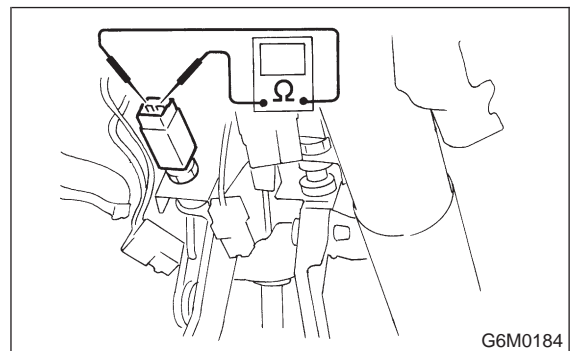

- CHECK** : *Is resistance less than 10  $\Omega$ ? (When clutch pedal is released.)*
- YES** : Go to step 8B6.
- NO** : Replace clutch switch.

#### 8B6 : CHECK CLUTCH SWITCH. (MT)

Check continuity of the clutch switch.

##### Terminals

**No. 1 — No. 2:**

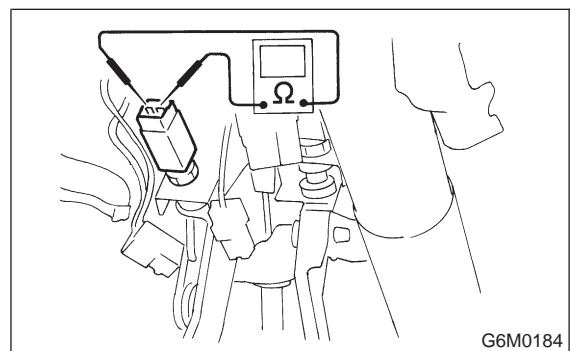

- CHECK** : *Is resistance more than 1 M $\Omega$ ? (When clutch pedal is depressed.)*
- YES** : Replace cruise control module.
- NO** : Replace clutch switch.

**8B7 : CHECK INHIBITOR SWITCH. (AT)**

- 1) Turn ignition switch to ON.
- 2) Turn cruise control main switch to ON.
- 3) Apply parking brake securely.
- 4) Set select monitor in "Current Data Display & Save" mode.
- 5) Set the selector lever from P or N position to D position and check signal for proper operation. The Clutch/Inhibitor Switch shown on the display turns from "ON" to "OFF".
- 6) Set the selector lever to P or N position.
- 7) Disconnect connector of inhibitor switch.
- 8) Check continuity of the inhibitor switch.

**Terminals**

**No. 11 — No. 12:**

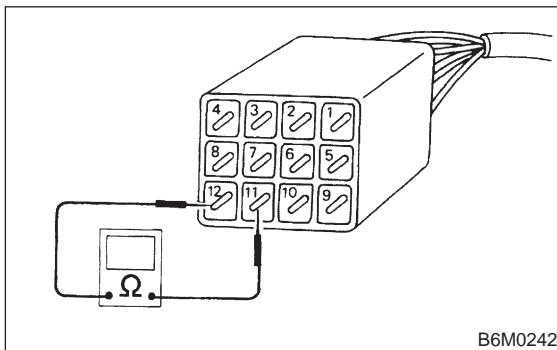

- CHECK** : *Is resistance less than 10 Ω? (When selector lever is in P or N.)*
- YES** : Go to step **8B8**.
- NO** : Replace inhibitor switch. Repair inhibitor switch wiring harness.

**8B8 : CHECK INHIBITOR SWITCH. (AT)**

Check continuity of the inhibitor switch.

**Terminals**

**No. 11 — No. 12:**

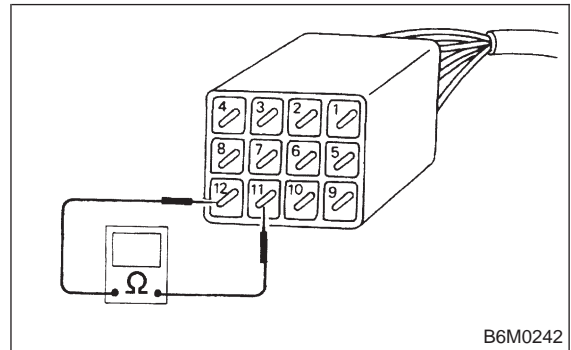

- CHECK** : *Is resistance more than 1 MΩ? (When selector lever is not in P or N.)*
- YES** : Replace cruise control module.
- NO** : Replace inhibitor switch. Repair inhibitor switch wiring harness.

# 6-2a [T8C0] BODY ELECTRICAL SYSTEM (CRUISE CONTROL)

## 8. Diagnostics Chart with Trouble Code

### C: DIAGNOSTIC TROUBLE CODE 12, 13 AND 21 (VEHICLE SPEED SENSOR 2 SYSTEM)

#### DIAGNOSIS:

- Disconnection or short circuit of vehicle speed sensor 2 system.

#### TROUBLE SYMPTOM:

- Cruise control cannot be set. (Cancelled immediately.)

#### WIRING DIAGRAM:

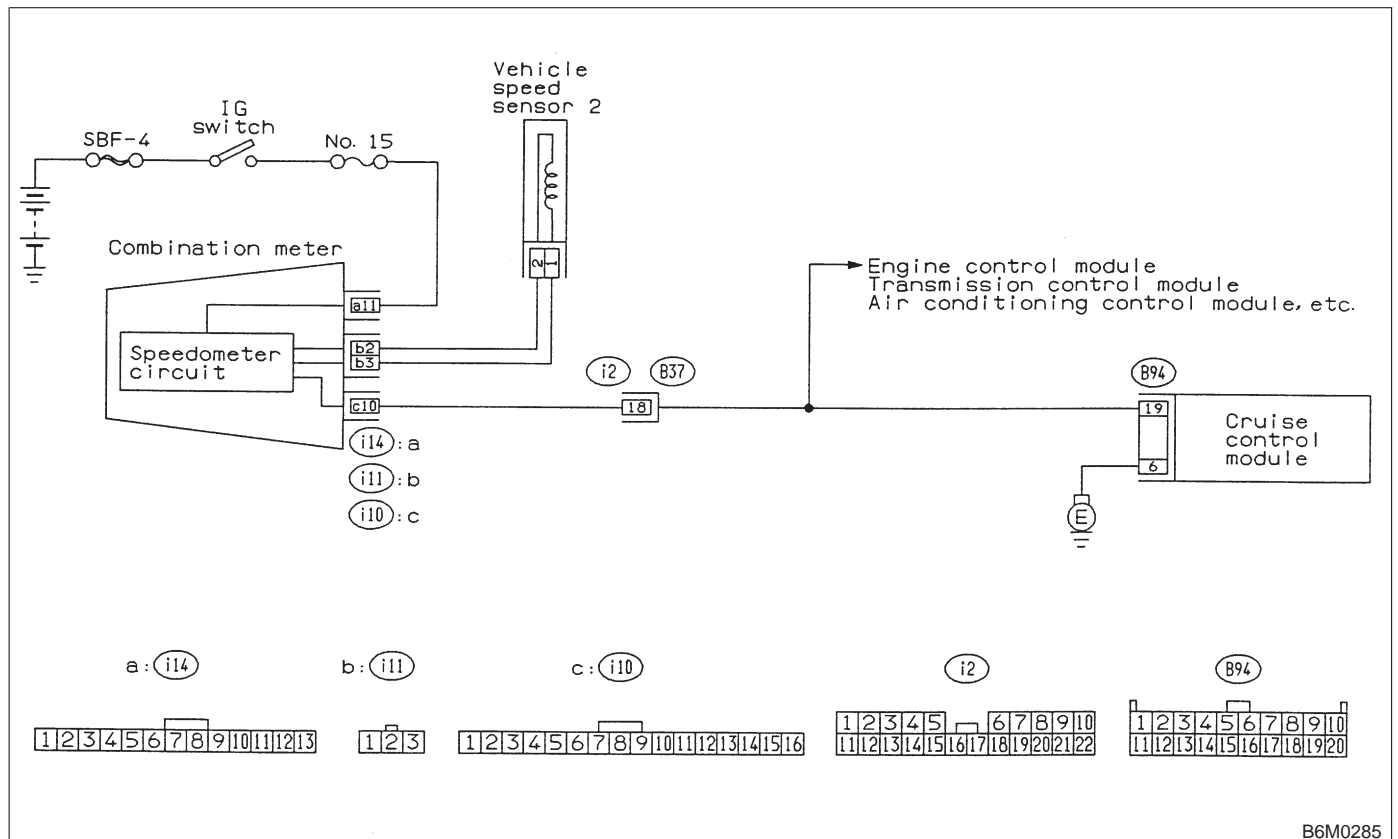

B6M0285

**8C1 : CHECK OPERATION OF SPEEDOMETER.**

Make sure that speedometer indicates the vehicle speed by driving the vehicle.

- CHECK** : *Does speedometer indicate vehicle speed by driving vehicle?*
- YES** : Go to step **8C2**.
- NO** : Repair combination meter circuit.

**8C2 : CHECK INPUT SIGNAL FOR CRUISE CONTROL MODULE.**

**WARNING:**

**Be careful not to be caught up by the running wheels.**

- 1) Set the vehicle on free roller, or lift-up the vehicle and support with safety stands.
- 2) Set oscilloscope to cruise control module connector terminals.
- 3) Start the engine.
- 4) Shift on the gear position, and keep the vehicle speed at constant.
- 5) Measure signal voltage.

**Connector & terminal**

**(B94) No. 19 (+) — Chassis ground (-):**

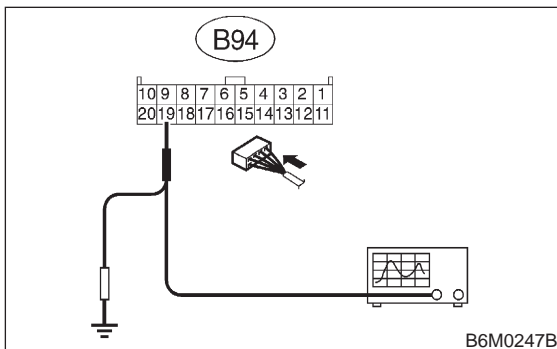

- CHECK** : *Is the voltage more than 2 V?*
- YES** : Replace cruise control module.
- NO** : Go to step **8C3**.

**NOTE:**

- If the vehicle speed increases, the width of amplitude (W) decreases.

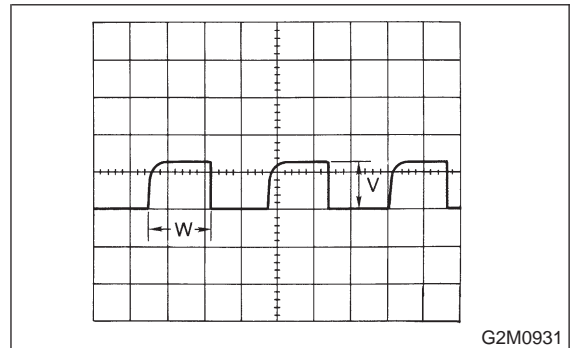

- If oscilloscope is not available, check input signal (vehicle speed signal) by using a select monitor. (Refer to the procedure as described below.)
- Using the select monitor:
  - 1) Set the vehicle on free roller, or lift-up the vehicle and support with safety stands.
  - 2) Turn ignition switch to OFF and set select monitor.
  - 3) Turn ignition switch to ON.
  - 4) Turn cruise control main switch to ON.
  - 5) Set select monitor in "Current Data Display & Save" mode.
  - 6) Drive the vehicle at speed greater than 40 km/h (25 MPH).
  - 7) Check that vehicle speed indication on select monitor and speedometer are equal.
- When there is a disconnection or short circuit in the harness between the meter and the cruise control module, the indicated value will be 0 to 1.0 km/h (0 to 0.6 MPH).

## 6-2a [T8C3] BODY ELECTRICAL SYSTEM (CRUISE CONTROL)

### 8. Diagnostics Chart with Trouble Code

#### 8C3 : PERFORM A CIRCUIT TEST BETWEEN COMBINATION METER AND CRUISE CONTROL MODULE.

- 1) Turn ignition switch to OFF.
- 2) Remove combination meter.

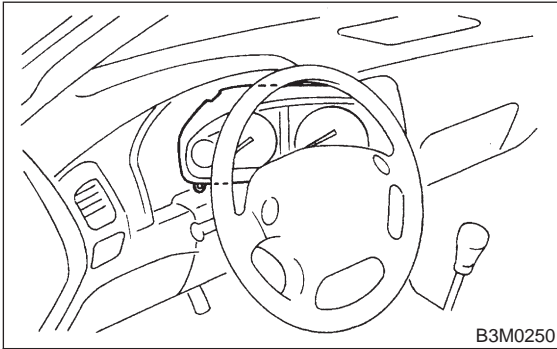

- 3) Disconnect connector from cruise control module.
- 4) Measure resistance of harness connector between combination meter and cruise control module.

**Connector & terminal**  
**(i10) No. 10 — (B94) No. 19:**

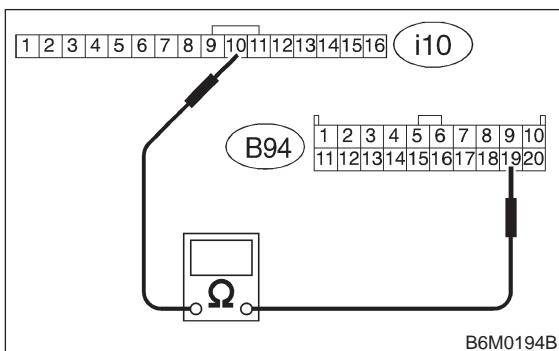

- CHECK** : Is resistance less than 10 Ω?  
**YES** : Go to step 8C4.  
**NO** : Repair or replace harness connector.

#### 8C4 : PERFORM A CIRCUIT TEST BETWEEN COMBINATION METER AND CRUISE CONTROL MODULE.

Measure resistance of harness connector between cruise control module and chassis ground to make sure that circuit does not short.

**Connector & terminal**  
**(B94) No. 19 (+) — Chassis ground (-):**

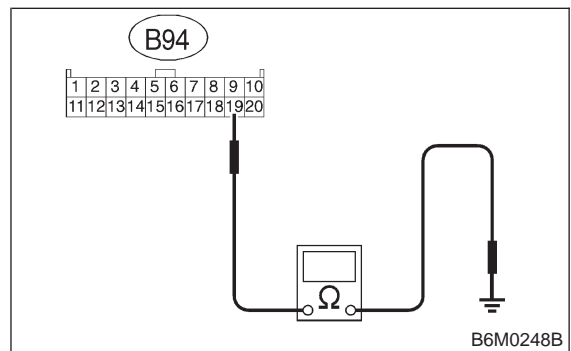

- CHECK** : Is resistance more than 1 MΩ?  
**YES** : Go to step 8C5.  
**NO** : Repair or replace harness connector.

#### 8C5 : CHECK VEHICLE SPEED SENSOR 2.

- 1) Disconnect connector from vehicle speed sensor 2.
- 2) Measure resistance between terminals of vehicle speed sensor 2.

**Terminals**  
**No. 1 — No. 2:**

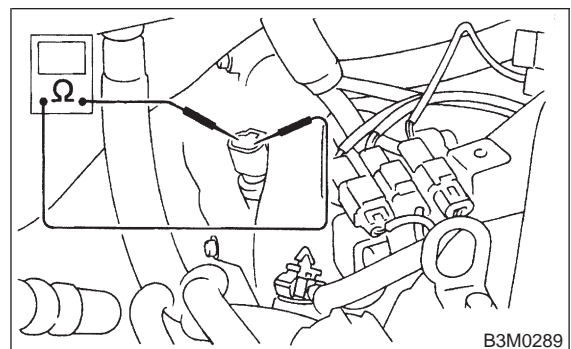

- CHECK** : Is resistance between 350 and 450 Ω?  
**YES** : Go to step 8C6.  
**NO** : Replace vehicle speed sensor 2.



**8C6 : CHECK VEHICLE SPEED SENSOR 2.**

1) Set the vehicle on free roller, or lift-up the vehicle and support with safety stands.

**WARNING:**

**Be careful not to be caught up by the running wheels.**

2) Drive the vehicle at speed greater than 20 km/h (12 MPH).

3) Measure voltage between terminals of vehicle speed sensor 2.

**NOTE:**

Using an oscilloscope:

- (1) Turn ignition switch to OFF.
- (2) Set oscilloscope to vehicle speed sensor 2.
- (3) Drive the vehicle at speed greater than 20 km/h (12 MPH).
- (4) Measure signal voltage.

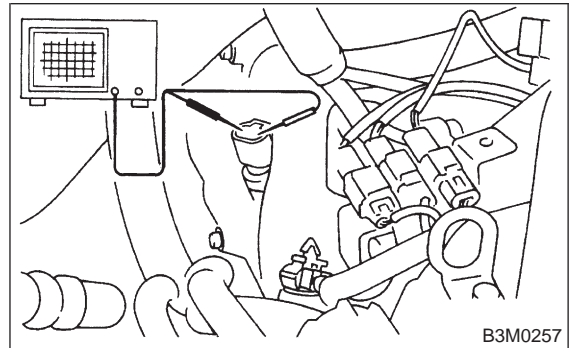
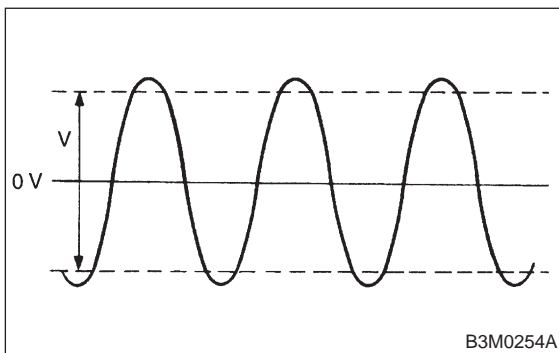

- CHECK** : *Is voltage more than 2 V (AC range)?*
- YES** : Repair or replace combination meter circuit.
- NO** : Replace vehicle speed sensor 2.

**Terminals**

**No. 1 — No. 2:**

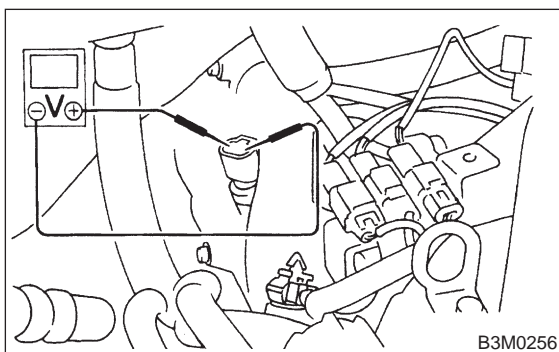

# 6-2a [T8D0] BODY ELECTRICAL SYSTEM (CRUISE CONTROL)

8. Diagnostics Chart with Trouble Code

## D: DIAGNOSTIC TROUBLE CODE 14 AND 22 (SET/COAST SWITCH, RESUME/ACCEL SWITCH, CANCEL SWITCH)

### DIAGNOSIS:

- Short circuit inside the SET/COAST SW and RESUME/ACCEL SW.

### TROUBLE SYMPTOM:

- Cruise control cannot be set. (Cancelled immediately.)

### WIRING DIAGRAM:

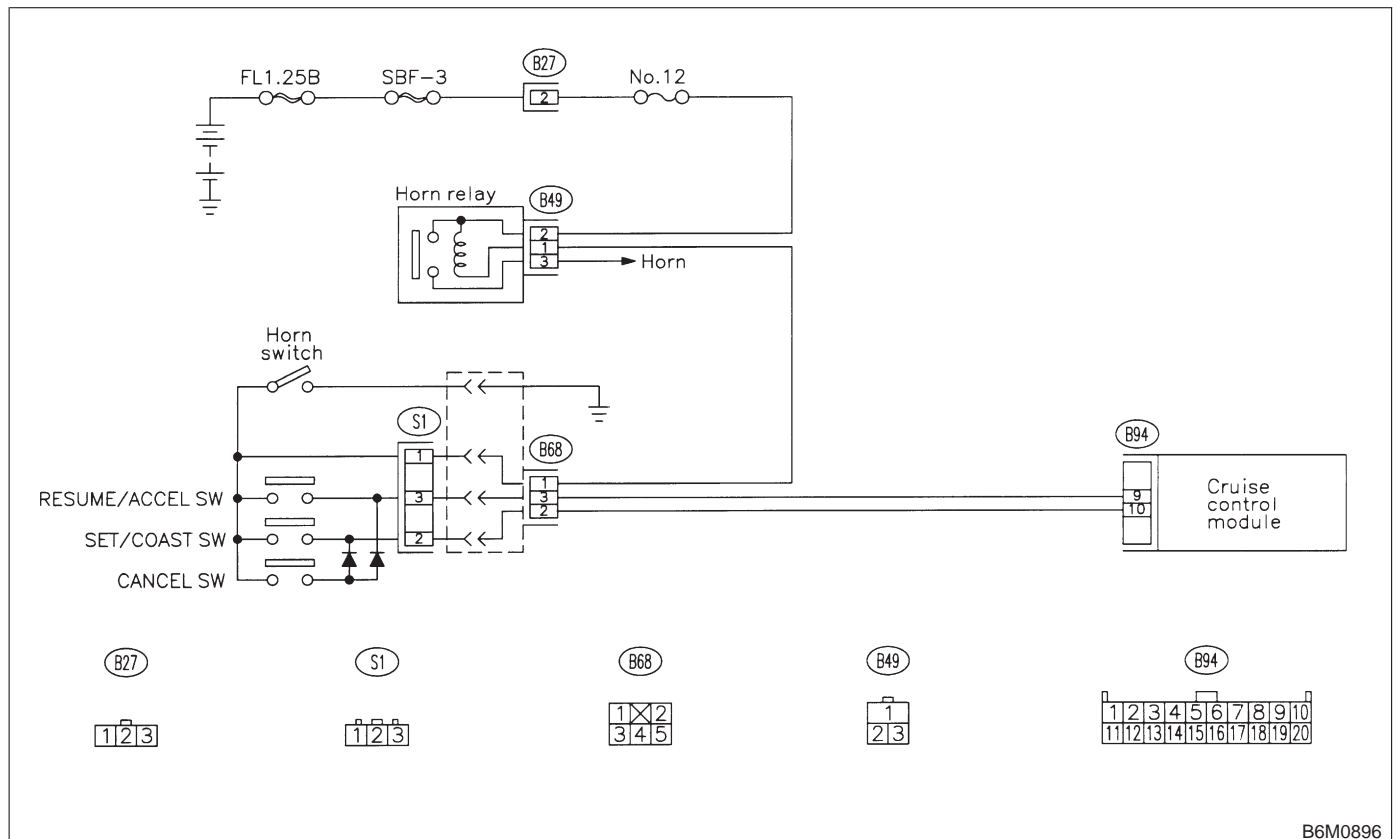

B6M0896

**8D1 : CHECK POWER SUPPLY.**

- 1) Turn ignition switch to ON.
- 2) Turn cruise control main switch to ON.
- 3) Set select monitor in "Current Data Display & Save" mode.
- 4) Check signals for proper operation.
  - (1) When pushing the SET/COAST switch:  
The SET/COAST switch shown on the display turns from "OFF" to "ON".
  - (2) When pushing the RESUME/ACCEL switch:  
The RESUME/ACCEL switch shown on the display turns from "OFF" to "ON".
- 5) Turn ignition switch to OFF.
- 6) Disconnect connector from cruise control command switch.
- 7) Turn ignition switch to ON.
- 8) Measure voltage between cruise control command switch connector and chassis ground.

**Terminals**

**(S1) No. 1 (+) — Chassis ground (-):**

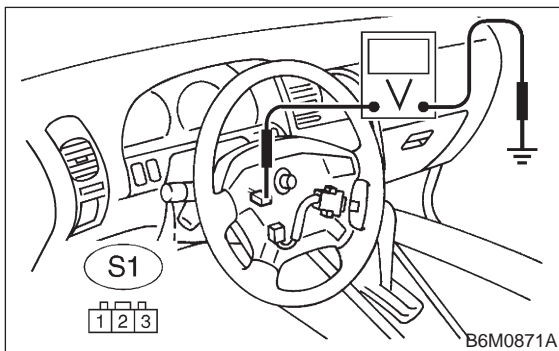

- CHECK** : **Is voltage more than 10 V?**
- YES** : Go to step **8D2**.
- NO** : Repair or replace wiring harness between fuse & relay box and cruise control command switch.

**8D2 : CHECK CRUISE CONTROL COMMAND SWITCH.**

- 1) Turn ignition switch to OFF.
- 2) Connect connector of cruise control command switch.
- 3) Turn ignition switch to ON.
- 4) Measure voltage between cruise control command switch connector and chassis ground.

**Terminals**

**(S1) No. 2 (+) — Chassis ground (-):**

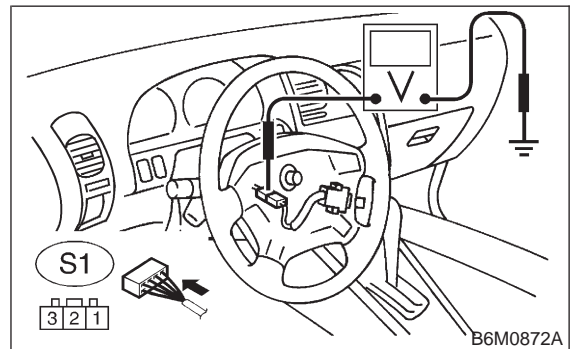

- CHECK** : **Is voltage more than 10 V? (When SET/COAST switch is ON.)**
- YES** : Go to step **8D3**.
- NO** : Replace cruise control command switch.

**8D3 : CHECK CRUISE CONTROL COMMAND SWITCH.**

Measure voltage between cruise control command switch connector and chassis ground.

**Terminals**

**(S1) No. 3 (+) — Chassis ground (-):**

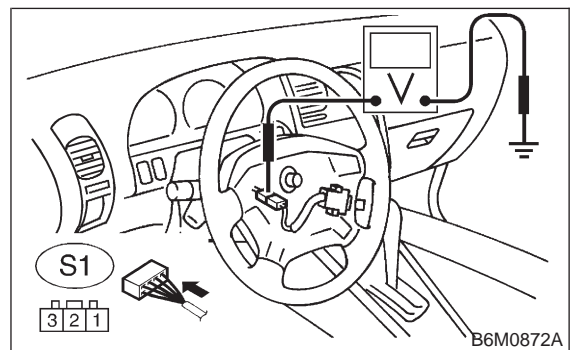

- CHECK** : **Is voltage more than 10 V? (When RESUME/ACCEL switch is ON.)**
- YES** : Go to step **8D4**.
- NO** : Replace cruise control command switch.

## 6-2a [T8D4] BODY ELECTRICAL SYSTEM (CRUISE CONTROL)

### 8. Diagnostics Chart with Trouble Code

#### 8D4 : CHECK CRUISE CONTROL COMMAND SWITCH.

Measure voltage between cruise control command switch connector and chassis ground.

##### Terminals

(S1) No. 2 (+) — Chassis ground (-):

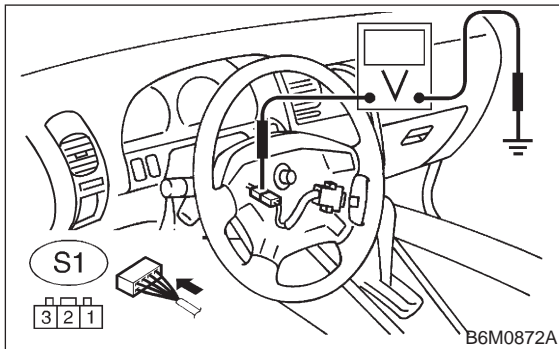

**CHECK** : Is voltage more than 10 V? (When CANCEL switch is ON.)

**YES** : Go to step 8D5.

**NO** : Replace cruise control command switch.

#### 8D5 : CHECK CRUISE CONTROL COMMAND SWITCH.

Measure voltage between cruise control command switch connector and chassis ground.

##### Terminals

(S1) No. 3 (+) — Chassis ground (-):

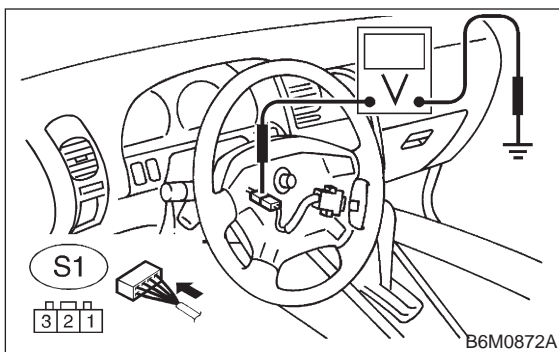

**CHECK** : Is voltage more than 10 V? (When CANCEL switch is ON.)

**YES** : Go to step 8D6.

**NO** : Replace cruise control command switch.

#### 8D6 : CHECK CRUISE CONTROL COMMAND SWITCH.

- 1) Turn ignition switch to OFF.
- 2) Disconnect connector from cruise control command switch.
- 3) Measure resistance between terminals of cruise control command switch connector (switch side) to check the switch operation.

##### Terminals

No. 1 — No. 2:

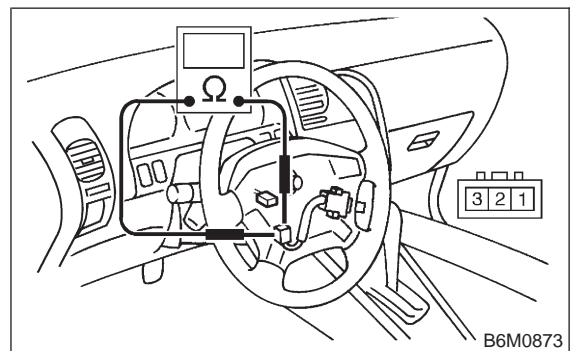

**CHECK** : Is resistance less than 10 Ω? (When SET/COAST switch is ON.)

**YES** : Go to step 8D7.

**NO** : Replace cruise control command switch.

**8D7 : CHECK CRUISE CONTROL COMMAND SWITCH.**

Measure resistance between terminals of cruise control command switch connector (switch side) to check the switch operation.

**Terminals**

**No. 1 — No. 2:**

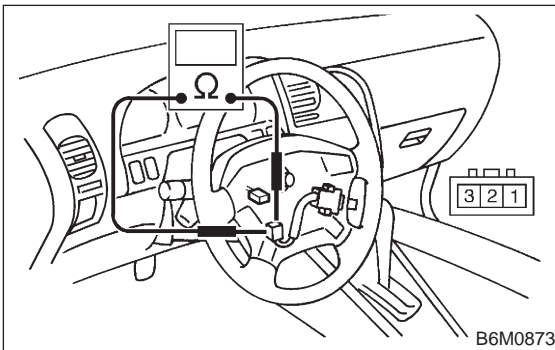

**CHECK** : **Is resistance more than 1 MΩ? (When SET/COAST switch is OFF.)**

**YES** : Go to step 8D8.

**NO** : Replace cruise control command switch.

**8D8 : CHECK CRUISE CONTROL COMMAND SWITCH.**

Measure resistance between terminals of cruise control command switch connector (switch side) to check the switch operation.

**Terminals**

**No. 1 — No. 3:**

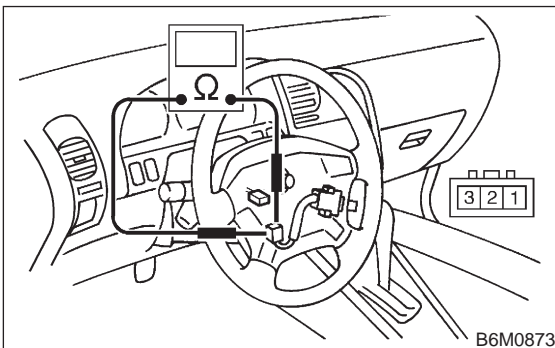

**CHECK** : **Is resistance less than 10 Ω? (When RESUME/ACCEL switch is ON.)**

**YES** : Go to step 8D9.

**NO** : Replace cruise control command switch.

**8D9 : CHECK CRUISE CONTROL COMMAND SWITCH.**

Measure resistance between terminals of cruise control command switch connector (switch side) to check the switch operation.

**Terminals**

**No. 1 — No. 3:**

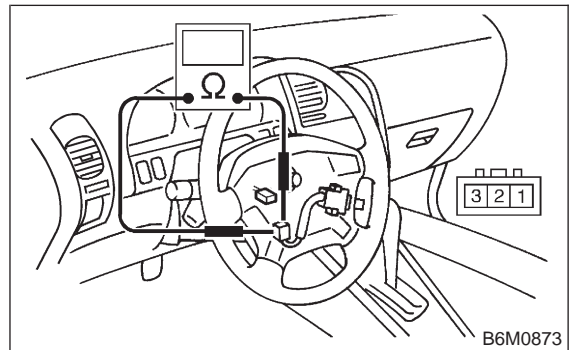

**CHECK** : **Is resistance more than 1 MΩ? (When RESUME/ACCEL switch is OFF.)**

**YES** : Go to step 8D10.

**NO** : Replace cruise control command switch.

**8D10 : CHECK HARNESS CONNECTOR BETWEEN CRUISE CONTROL COMMAND SWITCH AND CRUISE CONTROL MODULE.**

- 1) Disconnect connector from cruise control module.
- 2) Measure resistance of harness connector between cruise control command switch and cruise control module.

**Connector & terminal**

**(S1) No. 2 — (B94) No. 10:**

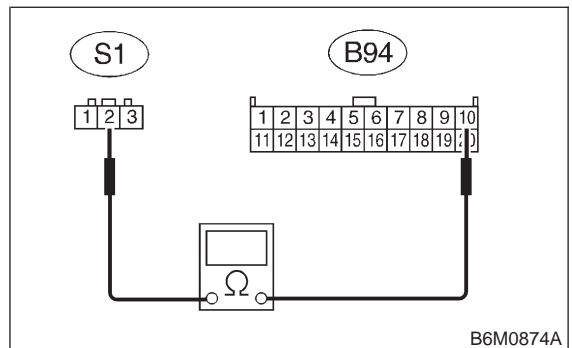

**CHECK** : **Is resistance less than 10 Ω?**

**YES** : Go to step 8D11.

**NO** : Repair or replace wiring harness.

## 6-2a [T8D11] BODY ELECTRICAL SYSTEM (CRUISE CONTROL)

### 8. Diagnostics Chart with Trouble Code

**8D11 : CHECK HARNESS CONNECTOR BETWEEN CRUISE CONTROL COMMAND SWITCH AND CRUISE CONTROL MODULE.**

Measure resistance of harness connector between cruise control command switch and cruise control module.

#### Connector & terminal

(S1) No. 3 — (B94) No. 9:

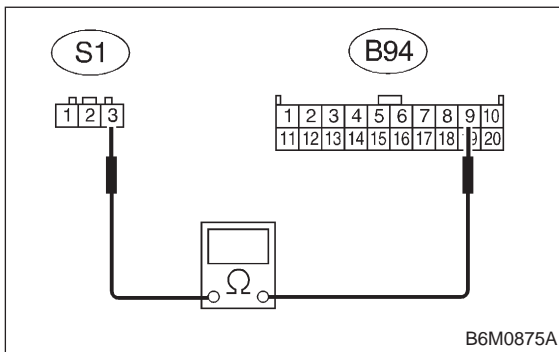

- CHECK** : Is resistance less than 10 Ω?  
**YES** : Replace cruise control module.  
**NO** : Repair or replace wiring harness.

### E: DIAGNOSTIC TROUBLE CODE 23 AND 24 (CRUISE CONTROL MODULE BUILT-IN RELAY, CPU RAM)

#### DIAGNOSIS:

- Poor welding of built-in relay of cruise control module.
- Failure of built-in CPU RAM of cruise control module.

#### TROUBLE SYMPTOM:

- Cruise control is canceled and memorized cruise speed is also canceled.
- Once cruise control is canceled, cruise control cannot be set until the ignition switch and cruise control main switch turns OFF, and then turns ON again.

#### NOTE:

Check input/output signal and vehicle speed signal with select monitor. When signals are in good condition, failure is in cruise control module. (Check power supply and ground conditions of cruise control module.)

**MEMO:**

# 6-2a [T8F0] BODY ELECTRICAL SYSTEM (CRUISE CONTROL)

8. Diagnostics Chart with Trouble Code

## F: DIAGNOSTIC TROUBLE CODE 31, 32 AND 33 (VACUUM PUMP, AIR VALVE, RELEASE VALVE)

### DIAGNOSIS:

- Open or poor contact of vacuum pump motor, air valve and release valve.

### TROUBLE SYMPTOM:

- Cruise control cannot be set. (Cancels immediately.)

### WIRING DIAGRAM:

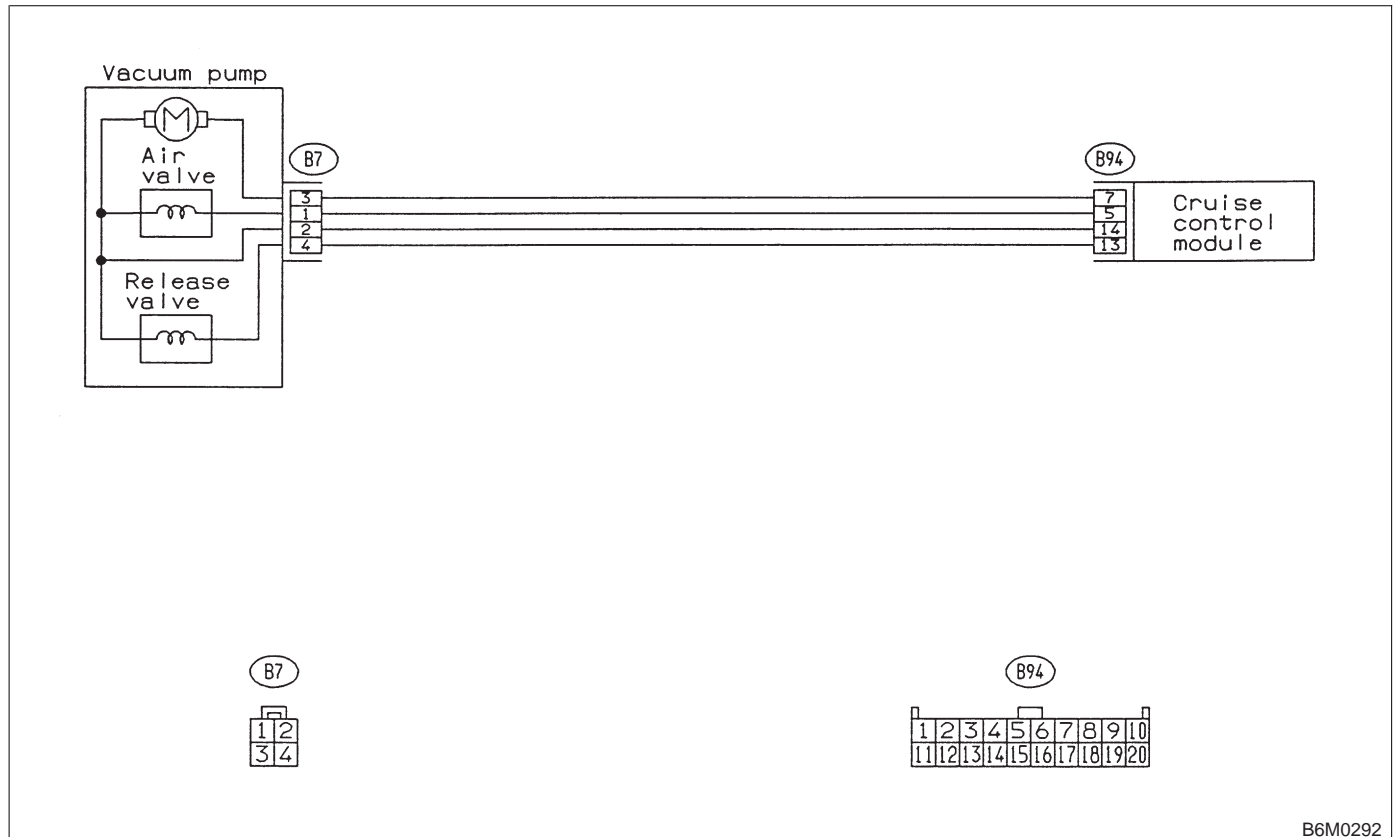

B6M0292



**8F1 : MEASURE RESISTANCE OF VACUUM PUMP MOTOR, AIR VALVE AND RELEASE VALVE.**

- 1) Disconnect connector from vacuum pump and valve.
- 2) Measure resistance of vacuum pump motor, air valve and release valve.

**Terminals**

**No. 2 — No. 3:**

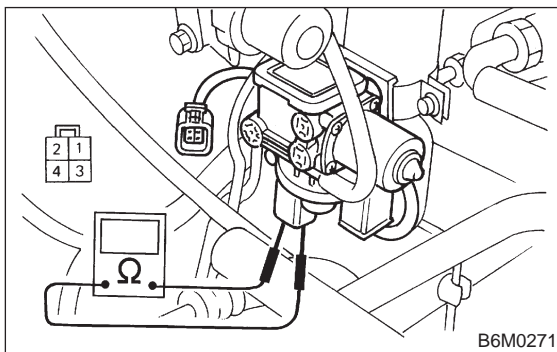

- CHECK** : Is resistance approximately 46 Ω?
- YES** : Go to step 8F2.
- NO** : Replace vacuum pump and valve.

**8F2 : MEASURE RESISTANCE OF VACUUM PUMP MOTOR, AIR VALVE AND RELEASE VALVE.**

Measure resistance of vacuum pump motor, air valve and release valve.

**Terminals**

**No. 2 — No. 1:**

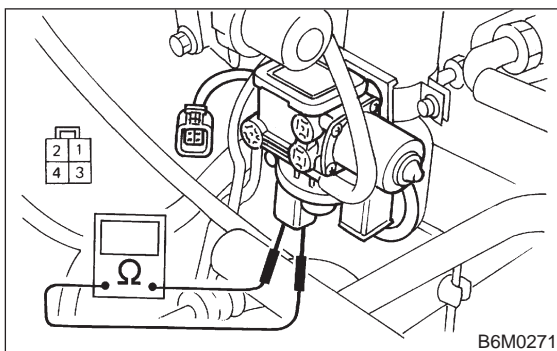

- CHECK** : Is resistance approximately 69 Ω?
- YES** : Go to step 8F3.
- NO** : Replace vacuum pump and valve.

**8F3 : MEASURE RESISTANCE OF VACUUM PUMP MOTOR, AIR VALVE AND RELEASE VALVE.**

Measure resistance of vacuum pump motor, air valve and release valve.

**Terminals**

**No. 2 — No. 4:**

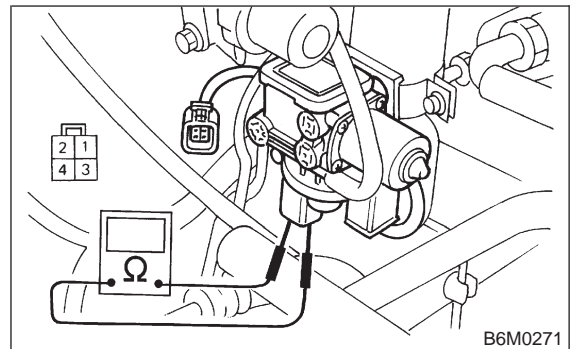

- CHECK** : Is resistance approximately 69 Ω?
- YES** : Go to step 8F4.
- NO** : Replace vacuum pump and valve.

**8F4 : PERFORM A CIRCUIT TEST IN HARNESS BETWEEN VACUUM PUMP & VALVE AND CRUISE CONTROL MODULE.**

- 1) Disconnect connector from cruise control module.
- 2) Measure resistance of harness connector between cruise control module, vacuum pump motor, air valve and release valve.

**Connector & terminal**

**(B7) No. 1 — (B94) No. 5:**

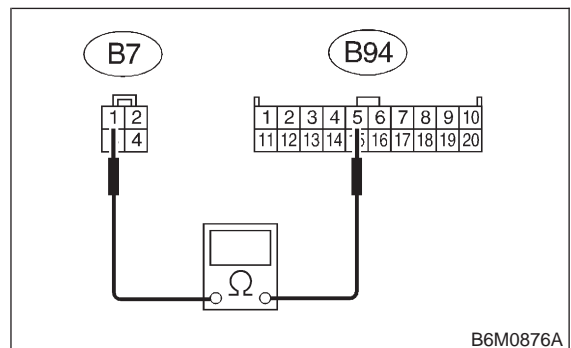

- CHECK** : Is resistance less than 10 Ω?
- YES** : Go to step 8F5.
- NO** : Repair or replace wiring harness between vacuum pump & valve and cruise control module.

## 6-2a [T8F5] BODY ELECTRICAL SYSTEM (CRUISE CONTROL)

### 8. Diagnostics Chart with Trouble Code

**8F5 : PERFORM A CIRCUIT TEST IN HARNESS BETWEEN VACUUM PUMP & VALVE AND CRUISE CONTROL MODULE.**

Measure resistance of harness connector between cruise control module, vacuum pump motor, air valve and release valve.

#### Connector & terminal

**(B7) No. 2 — (B94) No. 14:**

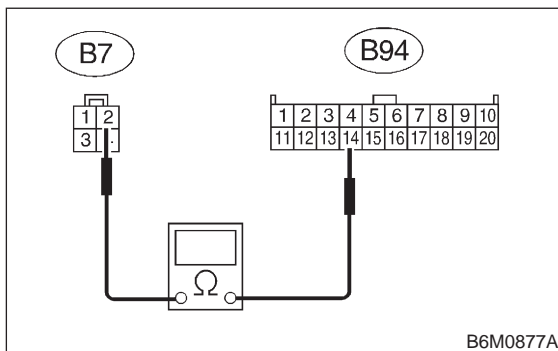

**CHECK** : *Is resistance less than 10 Ω?*

**YES** : Go to step **8F6**.

**NO** : Repair or replace wiring harness between vacuum pump & valve and cruise control module.

**8F6 : PERFORM A CIRCUIT TEST IN HARNESS BETWEEN VACUUM PUMP & VALVE AND CRUISE CONTROL MODULE.**

Measure resistance of harness connector between cruise control module, vacuum pump motor, air valve and release valve.

#### Connector & terminal

**(B7) No. 3 — (B94) No. 7:**

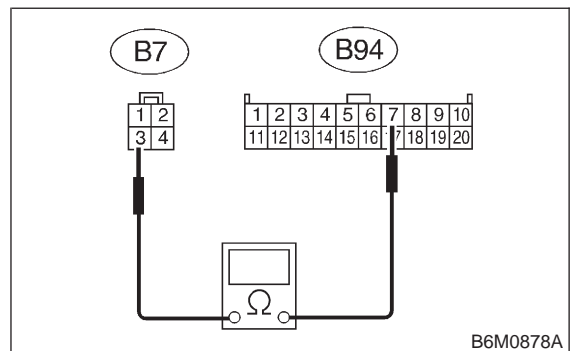

**CHECK** : *Is resistance less than 10 Ω?*

**YES** : Go to step **8F7**.

**NO** : Repair or replace wiring harness between vacuum pump & valve and cruise control module.

**8F7 : PERFORM A CIRCUIT TEST IN HARNESS BETWEEN VACUUM PUMP & VALVE AND CRUISE CONTROL MODULE.**

Measure resistance of harness connector between cruise control module, vacuum pump motor, air valve and release valve.

**Connector & terminal**

**(B7) No. 4 — (B94) No. 13:**

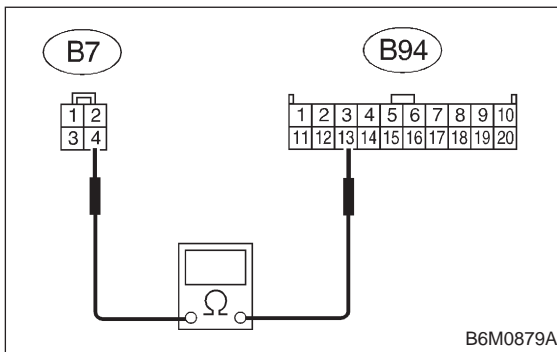

- CHECK** : **Is resistance less than 10 Ω?**
- YES** : Replace cruise control module.
- NO** : Repair or replace wiring harness between vacuum pump & valve and cruise control module.

## 9. Diagnostics Chart with Select Monitor

### A: FUNCTION MODE

NOTE:

Applicable select monitor cartridge:  
No. 24082AA010

Select the "Cruise Control" system using the select monitor and set the "Current Data Display & Save" mode. The following parameters will then appear on the display.

- Vehicle Speed

The current vehicle speed is shown on the display.

- Stop Lamp Switch

When the brake pedal is depressed, the stop lamp switch shown on the display turns from "OFF" to "ON".

- Brake Switch

When the brake pedal is depressed, the brake switch shown on the display turns from "OFF" to "ON".

- "SET/COAST" Switch

When the cruise control command switch is placed in the "SET/COAST" position, the SET/COAST switch shown on the display turns from "OFF" to "ON".

- "RESUME/ACCEL" Switch

When the cruise control command switch is placed in the "RESUME/ACCEL" position, the RESUME/ACCEL switch shown on the display turns from "OFF" to "ON".

- Clutch/Inhibitor Switch

When the clutch pedal is depressed, the clutch/inhibitor switch shown on the display turns from "ON" to "OFF". (MT)

When the selector lever is moved from the "N" or "P" position to any other position, the clutch/inhibitor switch shown on the display turns from "ON" to "OFF". (AT)