

## 10. Spot Light

### A: REMOVAL AND INSTALLATION

#### 1. SPOT LIGHT AND SWITCH

- 1) Pry spot light lens off using a screwdriver.
- 2) Remove screws which secure spot light body.

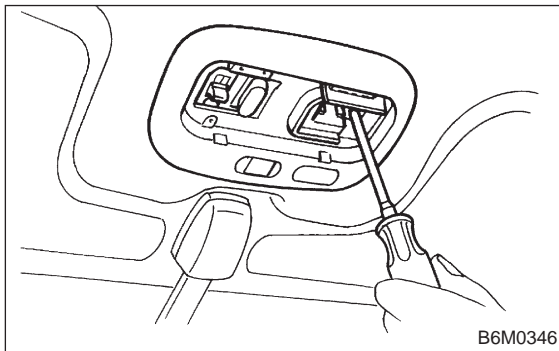

- 3) Remove spot light body while disconnecting connector(s).
- 4) Installation is in the reverse order of removal.

### B: INSPECTION

#### 1. SPOT LIGHT SWITCH

Move switch and check continuity between terminal of spot light switch connector and steel plate as shown.

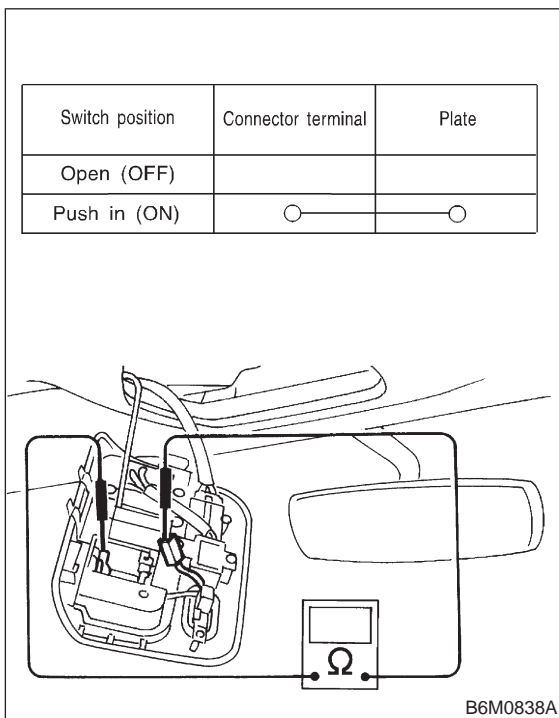

## 11. Front Wiper and Washer

### A: ADJUSTMENT

- 1) Turn the wiper switch to OFF position.
- 2) Adjust blades in original position as shown in figure by changing wiper arm installation.

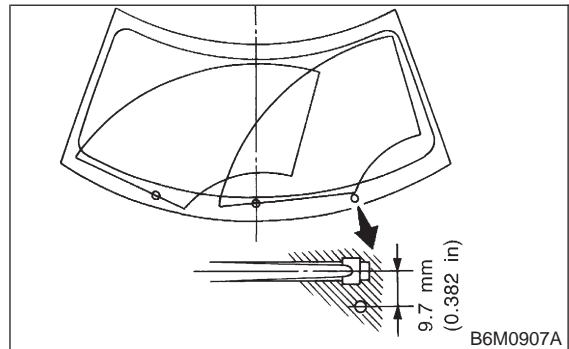

- 3) Stop the vehicle.
- 4) Adjust washer ejecting point on windshield glass as shown in figure.

#### Ejecting point:

- A: 375 mm (14.76 in)
- B: 150 mm (5.91 in)
- C: 380 mm (14.96 in)

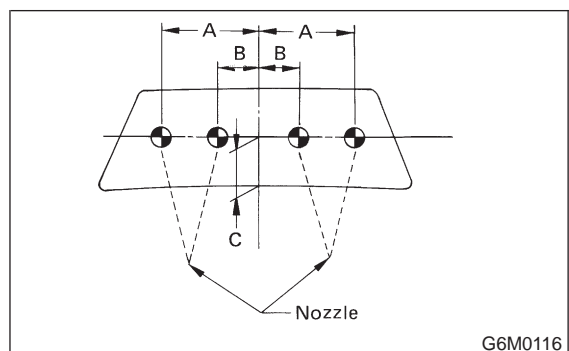

### B: REMOVAL AND INSTALLATION

#### 1. BLADE

- 1) Pull out blade following the arrow direction from arm while pushing up locking clip.

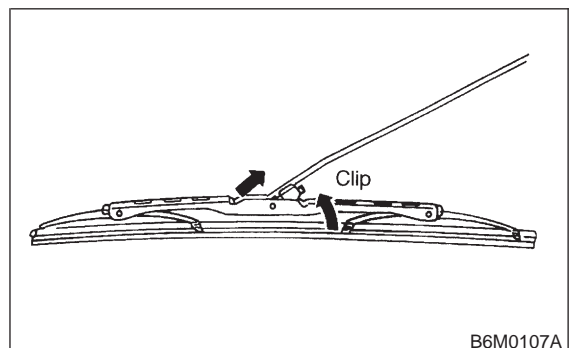

- 2) Installation is in the reverse order of removal.