

3. Camshaft

A: REMOVAL

1. RELATED PARTS

Remove timing belt, camshaft sprockets and related parts.
<Ref. to 2-3b [W2A0].>

2. CAMSHAFT

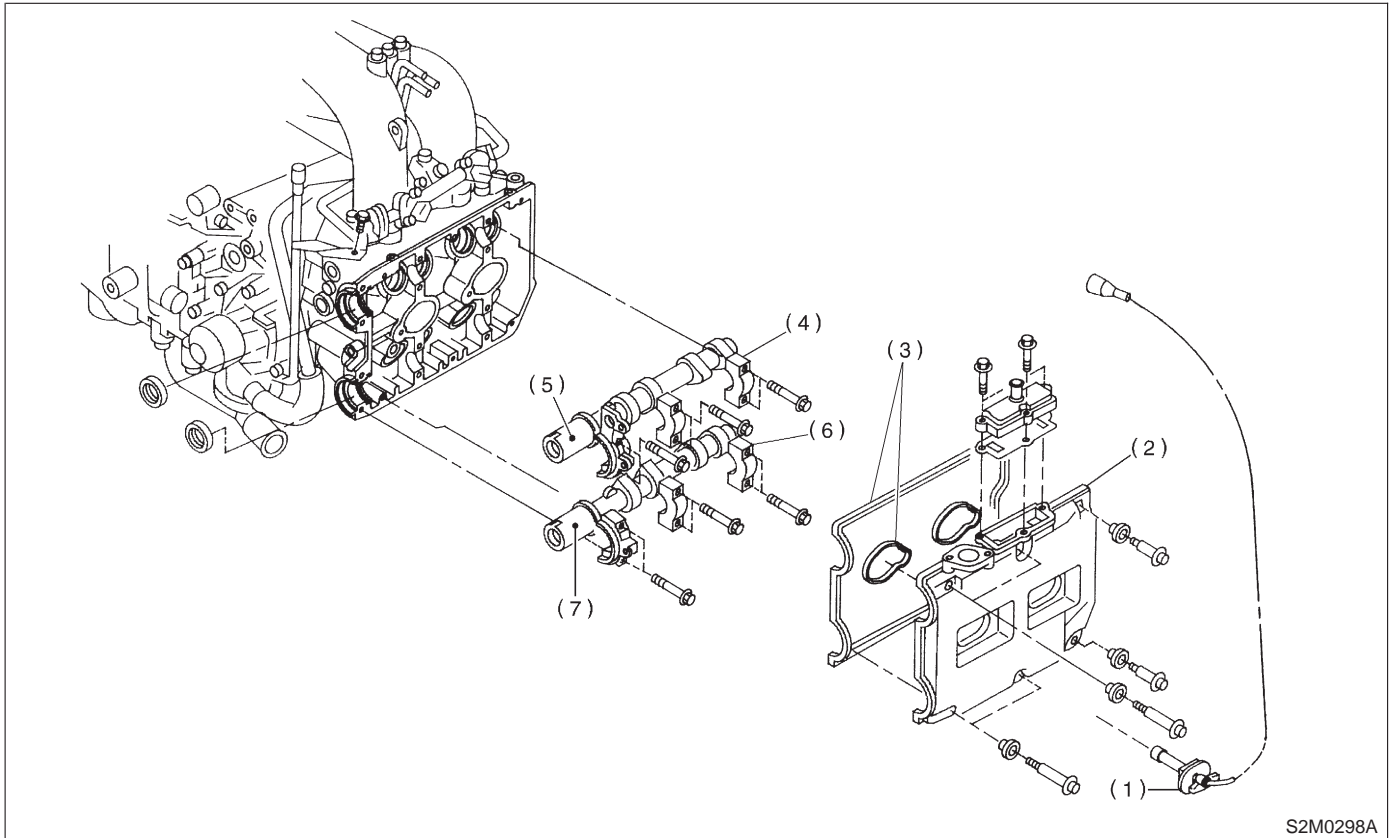

S2M0298A

- | | | |
|------------------------------|-------------------------------|---------------------------|
| (1) Spark plug cord | (4) Intake camshaft cap (LH) | (7) Exhaust camshaft (LH) |
| (2) Rocker cover (LH) | (5) Intake camshaft (LH) | |
| (3) Rocker cover gasket (LH) | (6) Exhaust camshaft cap (LH) | |

- 1) Remove camshaft position sensor (LH side only).
- 2) Remove spark plug cord.
- 3) Remove rocker cover and gasket.

- 4) Loosen intake camshaft cap bolts equally, a little at a time in alphabetical sequence shown in figure.

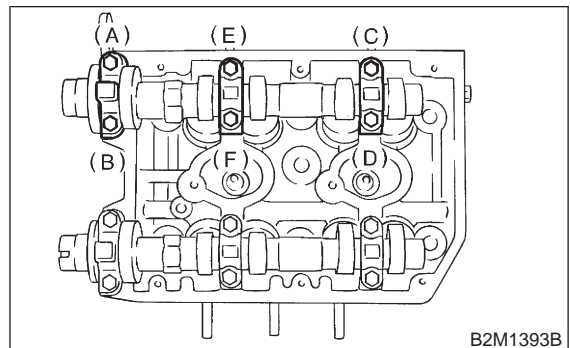

B2M1393B

- 5) Remove camshaft caps and intake camshaft.

6) Loosen exhaust camshaft cap bolts equally, a little at a time in alphabetical sequence shown in figure.

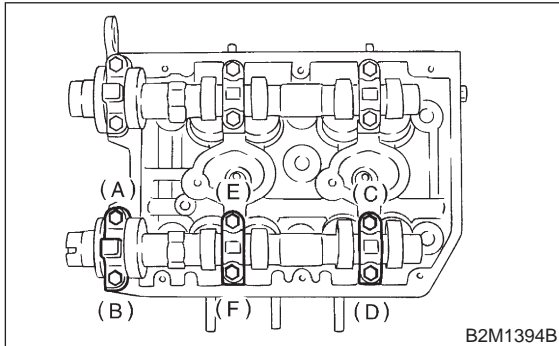

7) Remove camshaft caps and exhaust camshaft.

CAUTION:

Arrange camshaft caps in order so that they can be installed in their original positions.

8) Similarly, remove right-hand camshafts and related parts.

B: INSPECTION

1. CAMSHAFT

1) Measure the bend, and repair or replace if necessary.

Limit:

0.020 mm (0.0008 in)

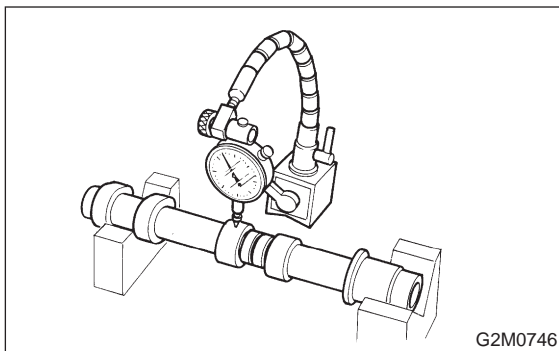

2) Check journal for damage and wear. Replace if faulty.

3) Measure outside diameter of camshaft journal. If the journal diameter is not as specified, check the oil clearance.

| | Camshaft journal | |
|----------|--|--|
| | Front | Center, rear |
| Standard | 31.946 — 31.963 mm (1.2577 — 1.2584 in) | 27.946 — 27.963 mm (1.1002 — 1.1009 in) |

4) Measurement of the camshaft journal oil clearance

- (1) Clean the bearing caps and camshaft journals.
 - (2) Place the camshafts on the cylinder head. (Without installing valve rocker.)
 - (3) Place plastigauge across each of the camshaft journals.
 - (4) Install the bearing caps.
- <Ref. to 2-3b [W3C1].>

CAUTION:

Do not turn the camshaft.

- (5) Remove the bearing caps.
 - (6) Measure the widest point of the plastigauge on each journal.
- If the oil clearance exceeds the limit, replace the camshaft. If necessary, replace the camshaft caps and cylinder head as a set.

Standard oil clearance:

0.037 — 0.072 mm (0.0015 — 0.0028 in)

Limit:

0.10 mm (0.0039 in)

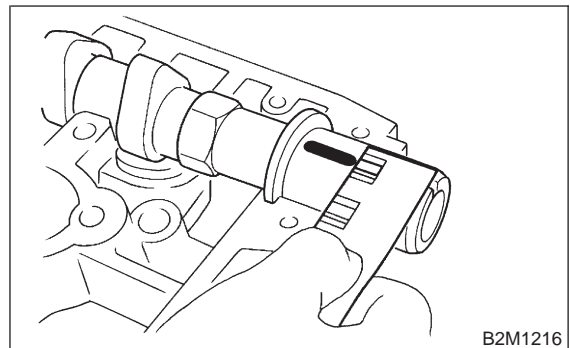

(7) Completely remove the plastigauge.

2-3b [W3B1]

3. Camshaft

SERVICE PROCEDURE

5) Check cam face condition; remove minor faults by grinding with oil stone. Measure the cam height H; replace if the limit has been exceeded.

Cam height: H

Standard:

Intake:

42.20 — 42.30 mm (1.6614 — 1.6654 in)

Exhaust:

Front: 42.50 — 42.60 mm (1.6732 — 1.6772 in)

Rear: 41.40 — 41.50 mm (1.6299 — 1.6339 in)

Limit:

Intake:

42.04 mm (1.6551 in)

Exhaust:

Front: 42.34 mm (1.6669 in)

Rear: 41.24 mm (1.6236 in)

Cam base circle diameter A:

28.0 mm (1.102 in)

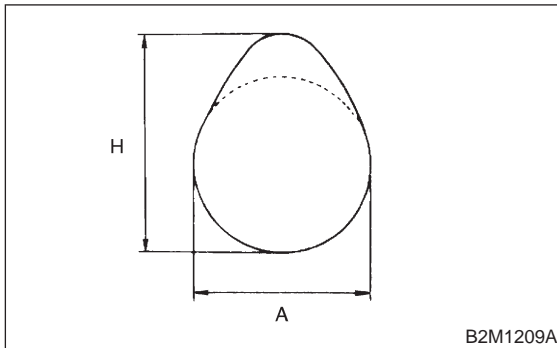

6) Measure the thrust clearance of camshaft with dial gauge. If the clearance exceeds the limit, replace caps and cylinder head as a set. If necessary replace camshaft.

Standard:

0.040 — 0.080 mm (0.0016 — 0.0031 in)

Limit:

0.1 mm (0.004 in)

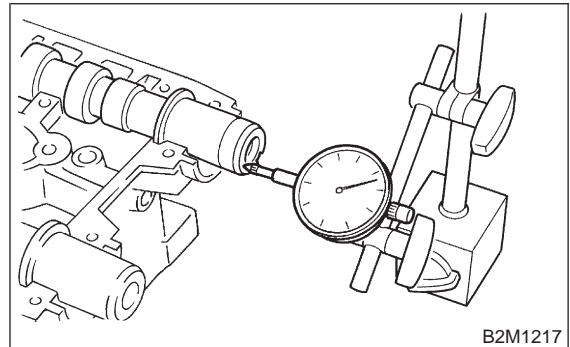

C: INSTALLATION

1. CAMSHAFT

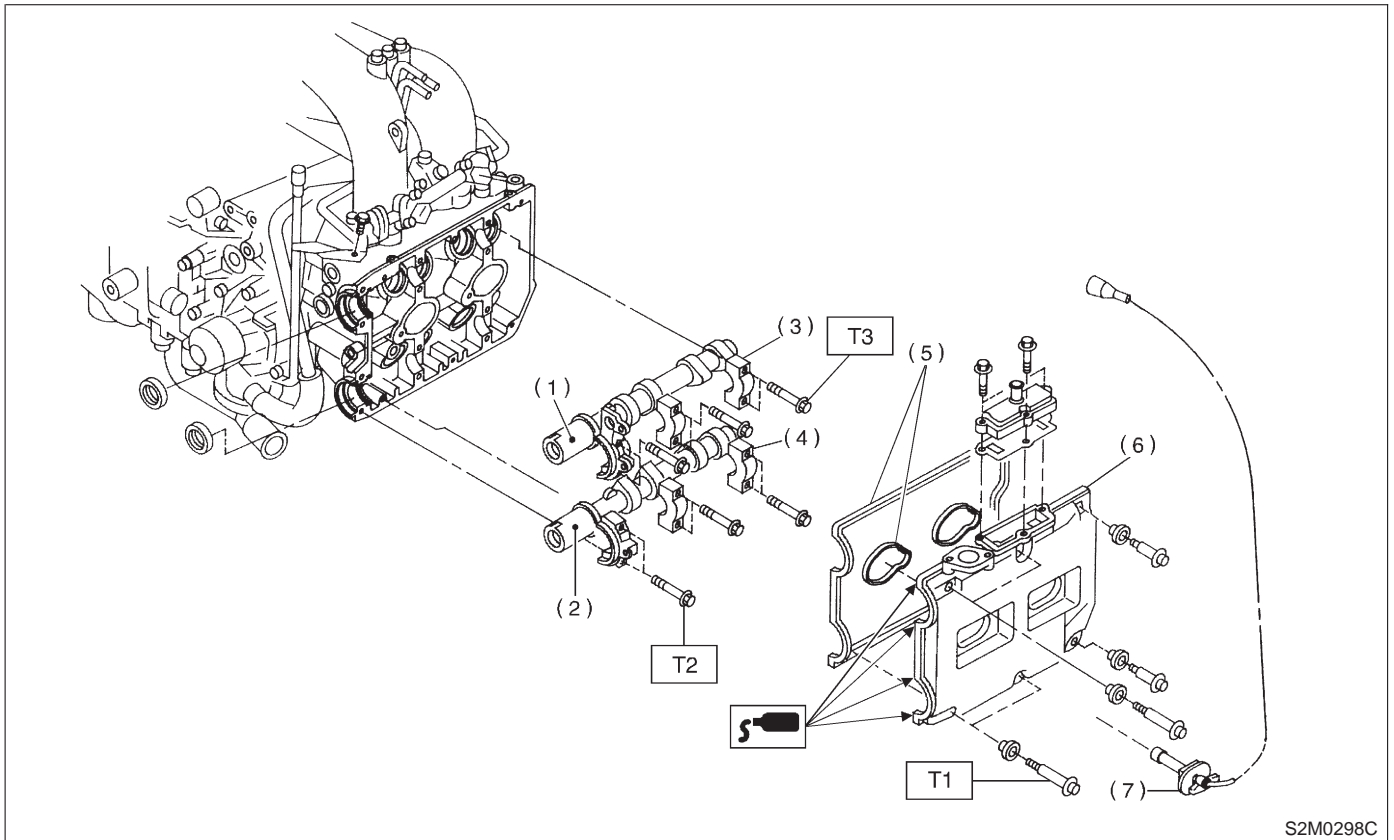

- | | |
|-------------------------------|-----------------------|
| (1) Intake camshaft (LH) | (6) Rocker cover (LH) |
| (2) Exhaust camshaft (LH) | (7) Spark plug cord |
| (3) Intake camshaft cap (LH) | |
| (4) Exhaust camshaft cap (LH) | |
| (5) Rocker cover gasket (LH) | |

Tightening torque: N-m (kg-m, ft-lb)

T1: 5±0.5 (0.5±0.05, 3.6±0.4)

T2: 10±0.7 (1.0±0.07, 7.2±0.5)

T3: 20±2 (2.0±0.2, 14.5±1.4)

2-3b [W3C1]

3. Camshaft

SERVICE PROCEDURE

1) Camshaft installation

Apply engine oil to cylinder head at camshaft bearing location before installing camshaft. Install camshaft so that rocker arm is close to or in contact with "base circle" of cam lobe.

CAUTION:

- When camshafts are positioned as shown in figure, camshafts need to be rotated at a minimum to align with timing belt during installation.

- Right-hand camshaft need not be rotated when set at position shown in figure.

Left-hand intake camshaft: Rotate 80° clockwise.

Left-hand exhaust camshaft: Rotate 45° counter-clockwise.

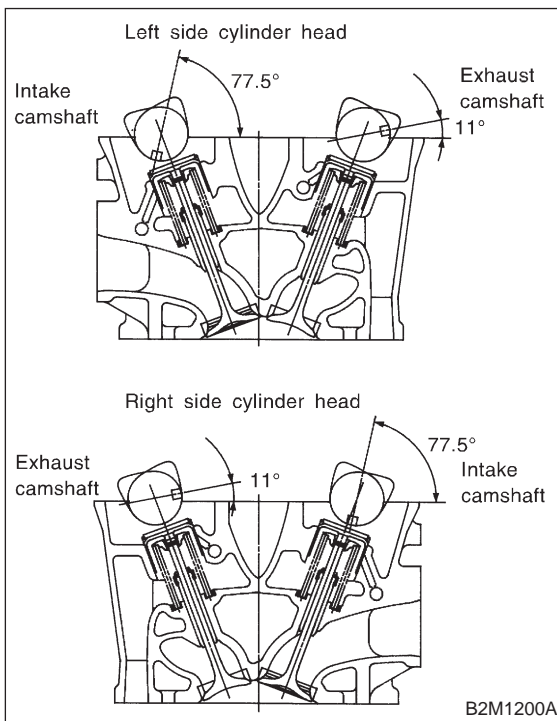

2) Camshaft cap installation

(1) Apply fluid packing sparingly to cap mating surface.

CAUTION:

Do not apply fluid packing excessively. Failure to do so may cause excess packing to come out and flow toward oil seal, resulting in oil leaks.

Fluid packing:

THREE BOND 1215 or equivalent

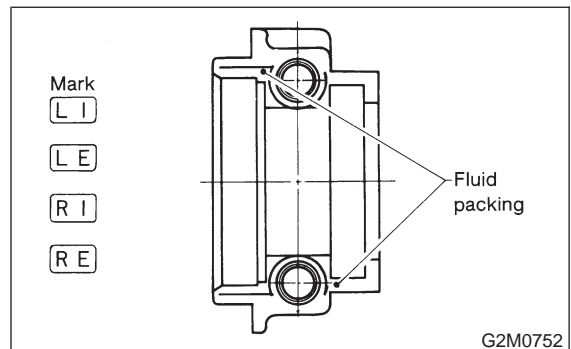

(2) Apply engine oil to cap bearing surface and install cap on camshaft as shown by identification mark.

(3) Gradually tighten cap in at least two stages in alphabetical sequence shown in figure, and then tighten to specified torque.

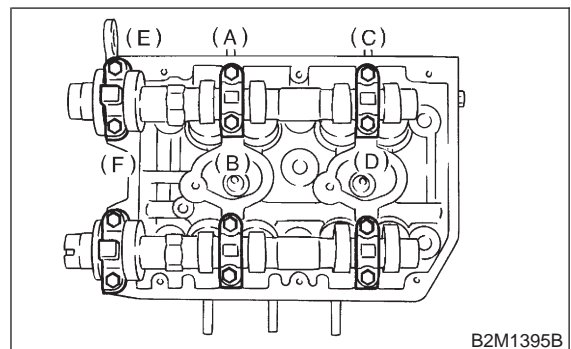

(4) Similarly, tighten cap on exhaust side. After tightening cap, ensure camshaft rotates only slightly while holding it at "base" circle.

3) Camshaft oil seal installation

Apply grease to new oil seal lips and press onto front end of camshaft by using ST1 and ST2.

CAUTION:

Use a new oil seal.

ST1 499587100 OIL SEAL INSTALLER

ST2 499597000 OIL SEAL GUIDE

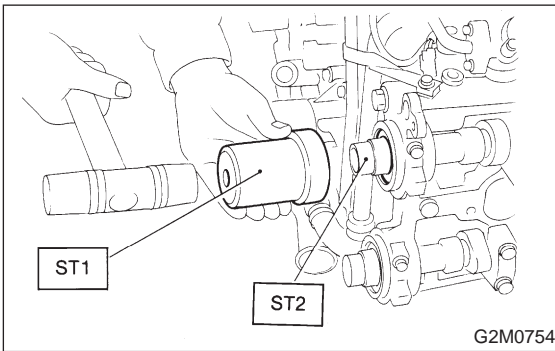

4) Rocker cover installation

(1) Install gasket on rocker cover.

Install peripheral gasket and ignition coil gasket.

(2) Apply fluid packing to four front open edges of peripheral gasket.

Fluid packing:

THREE BOND 1215 or equivalent

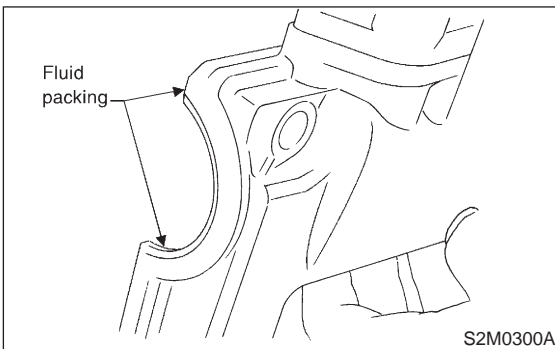

(3) Install rocker cover on cylinder head. Ensure gasket is properly positioned during installation.

5) Install ignition coil.

6) Install cam angle sensor.

7) Similarly, install parts on right-hand side.

2. RELATED PARTS

Install timing belt, camshaft sprockets and related parts.

<Ref. to 2-3b [W2C0].>