

### 3. Water Pipe

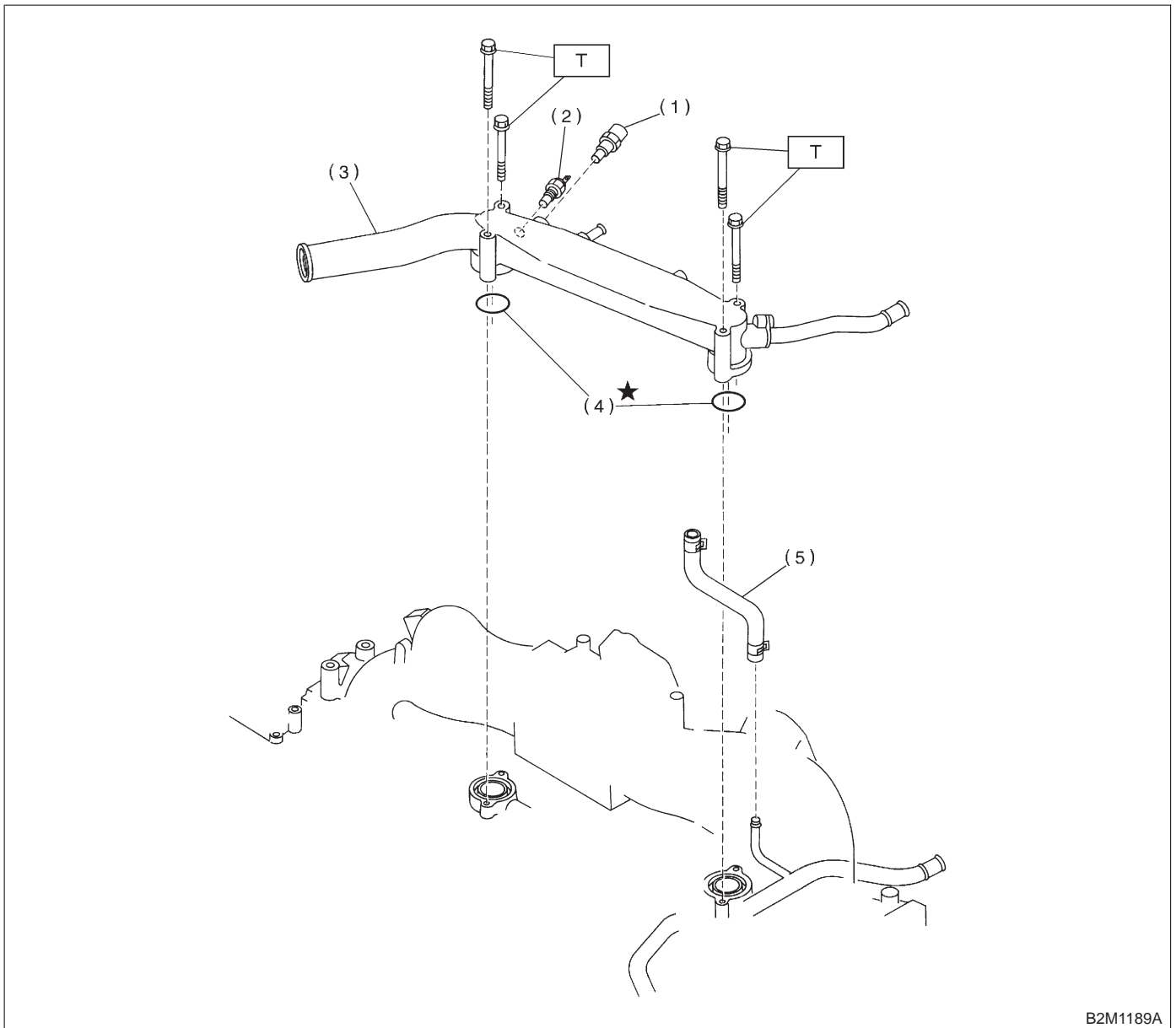

B2M1189A

- |                                       |                  |
|---------------------------------------|------------------|
| (1) Engine coolant temperature sensor | (3) Water pipe   |
| (2) Engine coolant temperature gauge  | (4) O-ring       |
|                                       | (5) By-pass hose |

**Tightening torque: N-m (kg-m, ft-lb)**  
**T: 6.4±0.5 (0.65±0.05, 4.7±0.4)**