

1. On-car Service

A: DRAINING OF ENGINE COOLANT

- 1) Lift-up the vehicle.
- 2) Fit vinyl tube to drain pipe.

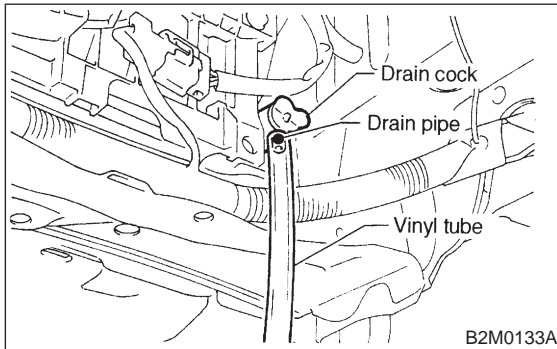

- 3) Loosen drain cock to drain engine coolant into container.

NOTE:

Remove radiator cap so that engine coolant will drain faster.

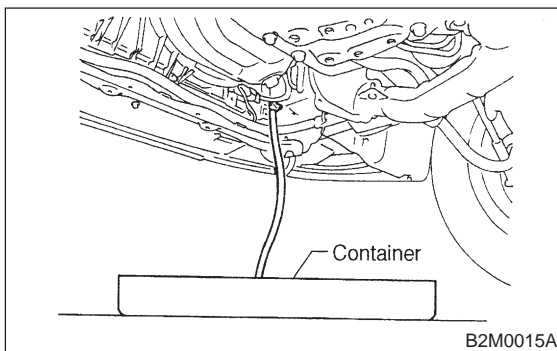

B: FILLING OF ENGINE COOLANT

- 1) Remove air vent plug from radiator.

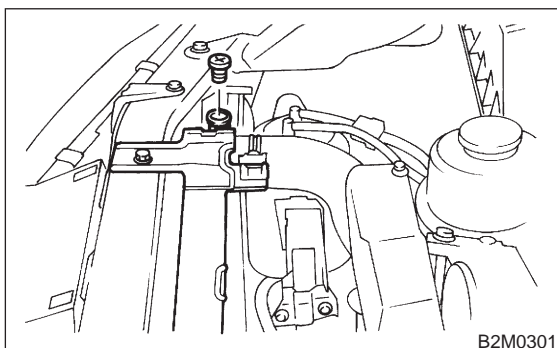

- 2) Fill engine coolant into radiator up to filler neck position.

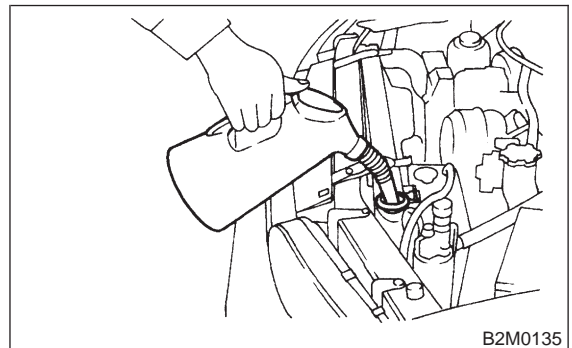

- 3) Fill engine coolant into reservoir tank up to upper level.

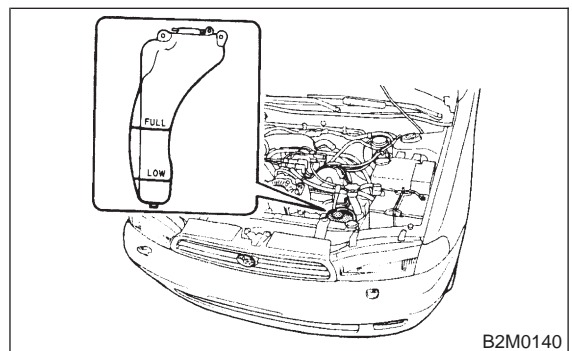

- 4) Attach radiator cap and reservoir tank cap properly.
- 5) Install air vent plug.
- 6) Warm-up engine completely for more than five minutes at 2,000 to 3,000 rpm.
- 7) Stop engine and wait until temperature drops to a safe level.
- 8) If engine coolant level drops in radiator, add engine coolant to filler neck position.
- 9) If engine coolant level drops from upper level of reservoir tank, add engine coolant to upper level.
- 10) Attach radiator cap and reservoir tank cap properly.

C: CHECKING OF COOLING SYSTEM

1) Remove radiator cap, top off radiator, and attach tester to radiator in place of cap.

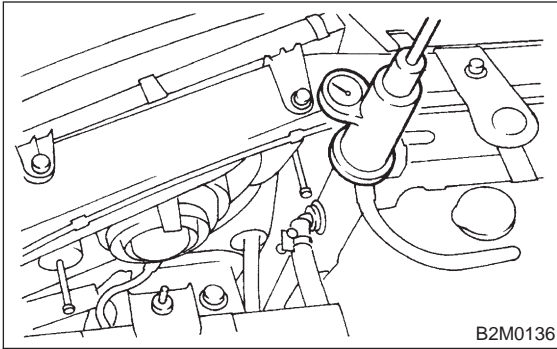

2) Apply a pressure of 157 kPa (1.6 kg/cm², 23 psi) to radiator to check if:
(1) Engine coolant leaks at/around radiator.
(2) Engine coolant leaks at/around hoses or connections.

CAUTION:

- Engine should be off.
- Wipe engine coolant from check points in advance.
- Be careful to prevent engine coolant from spurting out when removing tester.
- Be careful also not to deform filler neck of radiator when installing or removing tester.

2. Water Pump

A: REMOVAL

1) Disconnect ground cable from the battery.

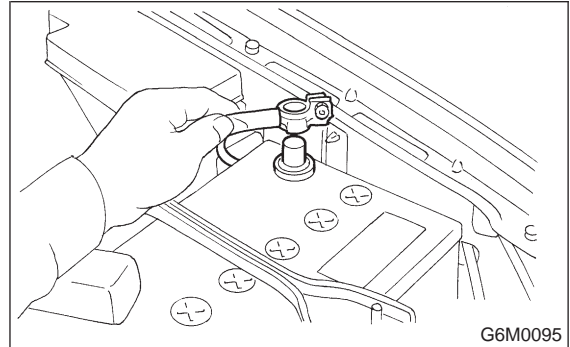

2) Lift-up the vehicle.
3) Remove under cover.

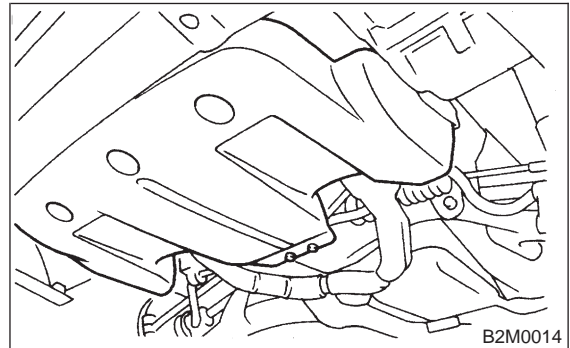

4) Drain engine coolant completely.
<Ref. to 2-5 [W1A0].>

