

4. Fuel Filter

A: REMOVAL

- 1) Release fuel pressure. <Ref. to 2-8 [W1B0].>
- 2) Disconnect fuel delivery hoses from fuel filter.

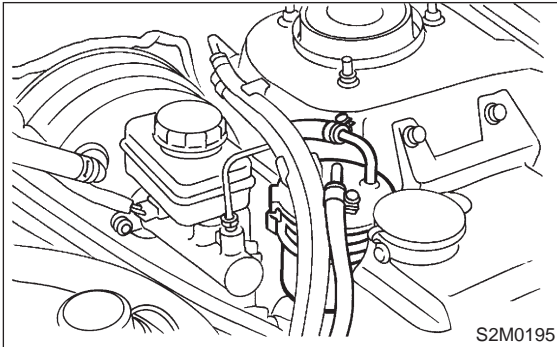

- 3) Remove filter from holder.

B: INSPECTION

- 1) Check the inside of fuel filter for dirt and water sediment.
- 2) If it is clogged, or if replacement interval has been reached, replace it.
- 3) If water is found in it, shake and expel the water from inlet port.

C: INSTALLATION

CAUTION:

- If fuel hoses are damaged at the connecting portion, replace it with a new one.
- If clamps are badly damaged, replace with new ones.

- 1) Installation is in the reverse order of removal.
- 2) Tighten hose clamp screws.

Tightening torque:

$1.0^{+0.5}/_{-0}$ N·m ($0.1^{+0.05}/_{-0}$ kg·m, $0.7^{+0.4}/_{-0}$ ft·lb)

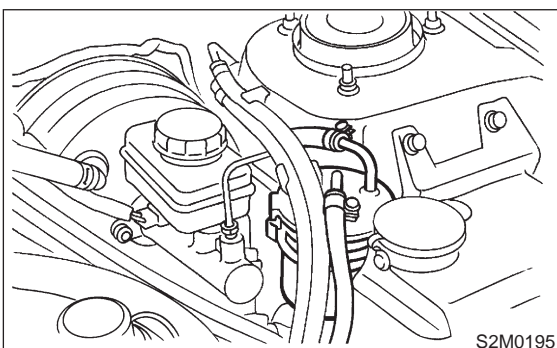

5. Fuel Pump

A: REMOVAL

- 1) Release fuel pressure. <Ref. to 2-8 [W1B0].>
- 2) Disconnect fuel delivery hose (A), return hose (B) and jet pump hose (C) (AWD model only).

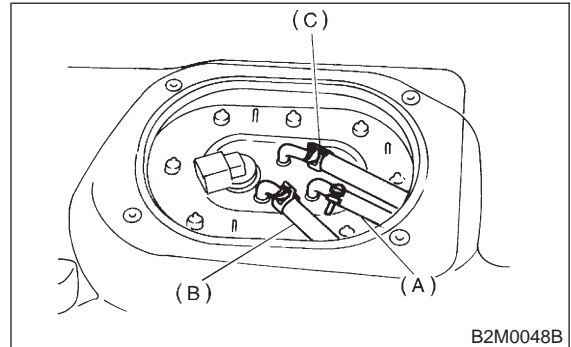

- 3) Remove nuts which install fuel pump assembly onto fuel tank.

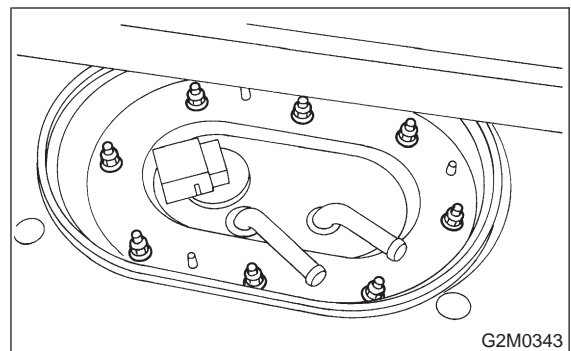

- 4) Take off fuel pump from fuel tank.

